

S9 High Voltage Alternators OWNER MANUAL

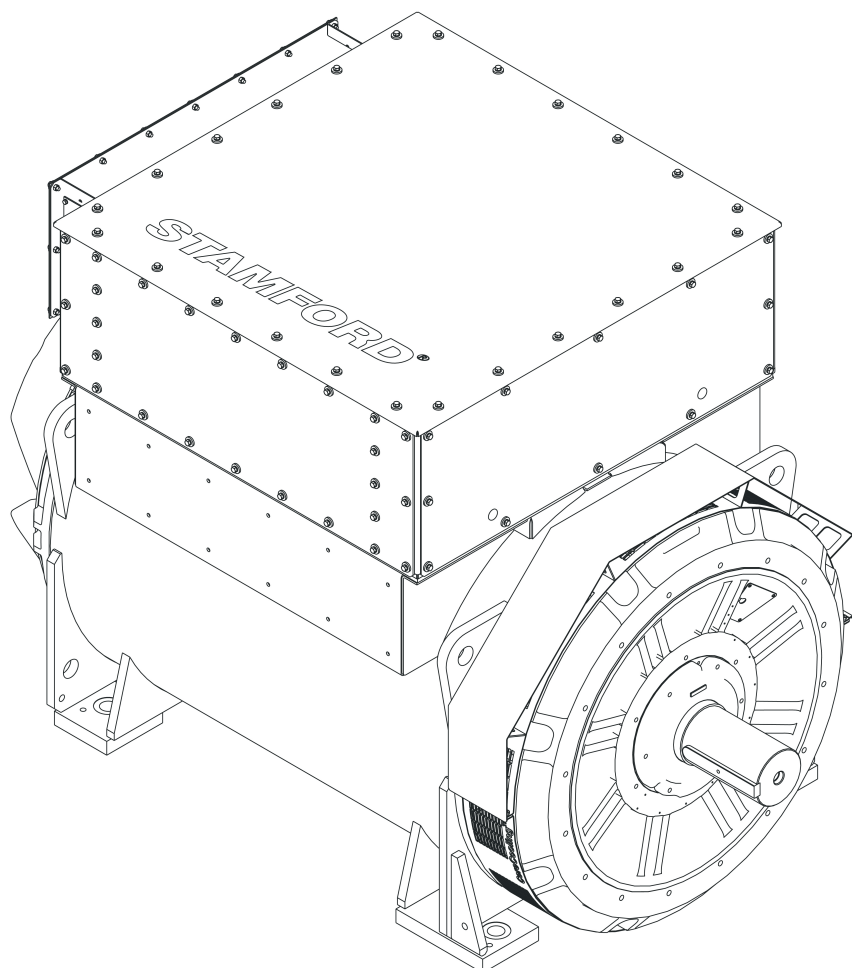

Table of Contents

1. FOREWORD	1
2. SAFETY PRECAUTIONS.....	3
3. SAFETY DIRECTIVES AND STANDARDS	13
4. INTRODUCTION	19
5. LIFTING, STORAGE AND TRANSPORTATION	21
6. APPLICATION OF THE ALTERNATOR	27
7. INSTALLATION INTO THE GENERATOR SET	35
8. SERVICE AND MAINTENANCE.....	45
9. PARTS IDENTIFICATION.....	71
10. TECHNICAL DATA.....	77
11. SERVICE PARTS.....	79
12. END OF LIFE DISPOSAL	81

-

This page is intentionally blank.

1 Foreword

1.1 General

This document is an important guide to the intended use and operation of the product(s) detailed on the front cover. Read the information and procedures in this document. The information and procedures must be obeyed at all times. Failure to obey the information and procedures can be considered misuse and can lead to injury, loss or damage to personnel or equipment.

TABLE 1. COMPANY ADDRESSES

Company and European Authorized Representative Addresses	
Cummins Generator Technologies Fountain Court Lynch Wood Peterborough PE2 6FZ United Kingdom	Cummins Generator Technologies Bvd. Decebal 116A Craiova Dolj 200746 Romania

1.2 Legal

The alternator is the intellectual property of Cummins Generator Technologies Ltd (also referred to as 'CGT' or 'the manufacturer' or by the brand names 'STAMFORD®' or 'AvK®' within this manual).

STAMFORD®, AvK® and STAMFORD VITA™, MX321™ and MX322™ are registered trademarks of Cummins Generator Technologies Ltd. All rights to the alternator, the principle of the machine, the related drawings etc. lie with Cummins Generator Technologies Ltd and are subject to copyright law. Copying is only permitted with prior written approval. Copyright Cummins Generator Technologies. All rights reserved. Cummins and the Cummins logo are registered trademarks of Cummins Inc.

1.3 The Manual

This manual contains guidance and instructions for the installation and operation of the equipment specified on the manual front cover. This manual does not include instructions for servicing and maintaining the alternator. Contact Cummins Generator Technologies (CGT) Customer Service for servicing information.

Before operating, the equipment, read this manual. Make sure that all personnel who work on the equipment have access to the manual and all related documentation supplied with it. Misuse, failure to obey the instructions or use of non-approved parts, may invalidate the product warranty and lead to loss injury or damage.

This manual is an essential part of the equipment. Make sure that the manual is available to all applicable personnel throughout the life of the equipment.

The manual is written for skilled electrical and mechanical technicians and engineers, who have prior knowledge and experience of equipment of this type. If in doubt, contact your local CGT subsidiary.

NOTICE

Information in this manual was correct when published. It may be superseded due to our policy of continuous improvement. Visit www.stamford-avk.com for latest documentation.

-

This page is intentionally blank.

2 Safety Precautions

2.1 Safety Information and Notices used in this Manual

Danger, Warning and Caution panels used in this manual describe the sources of hazards, their consequences and how to avoid injury. Notice panels emphasize important or critical instructions.

 DANGER
<i>Danger indicates a hazardous situation which, if not avoided, WILL result in death or serious injury.</i>

 WARNING
<i>Warning indicates a hazardous situation which, if not avoided, COULD result in death or serious injury.</i>

 CAUTION
<i>Caution indicates a hazardous situation which, if not avoided, COULD result in minor or moderate injury.</i>

NOTICE
Notice refers to a method or practice which can result in product damage, or to draw attention to additional information or explanations.

2.2 General Guidance

- These safety precautions are for general guidance. The information is intended to supplement your own safety procedures and applicable rules, laws and regulations.

2.3 Training and Skill Requirements for Personnel

Operation, installation, service and maintenance tasks and/or procedures can only be done by personnel, who:

- Have completed related, applicable and approved training.
- Know the equipment, understand the task(s) and procedure(s) and know the related hazards / risks.
- Know and obey site / location specific emergency procedures and applicable laws and regulations.

2.4 Risk Assessment

- The installer / operator / service / maintenance company must do a risk assessment to establish all related hazards and risks.
- During operation, access to the alternator must be restricted to personnel who are trained and who know all relevant hazards and risks. Refer to: [Section 2.3 on page 3](#).

2.5 Personal Protective Equipment (PPE)

Personnel who install, operate, service or maintain the alternator must:

- Have access to the minimum recommended protective equipment (refer to the figure below). The protective equipment must be approved for the task or procedure.
- Know how to correctly use protective equipment, refer to: [Section 2.3 on page 3](#)
- Use protective equipment as directed by the risk assessment, refer to: [Section 2.4 on page 3](#).



FIGURE 1. MINIMUM RECOMMENDED PERSONAL PROTECTIVE EQUIPMENT (PPE)

2.6 Tools and Equipment

All personnel must know how to use tools and equipment safely, refer to: [Section 2.3 on page 3](#).

All tools and equipment used, must be:

- Suitable for the task and procedure.
- Electrically insulated (not below the alternator output voltage), refer to: [Section 2.4 on page 3](#).
- In a serviceable condition for safe use.
- Included within the risk assessment, refer to: [Section 2.4 on page 3](#).

2.7 Safety Information Signs

Safety information signs are provided on the equipment to indicate hazards and emphasize instructions. Before operating the equipment:

- Personnel must know and understand alternator safety information signs and the associated hazards / risks.



FIGURE 2. EXAMPLE SAFETY INFORMATION SIGNS

Safety information signs vary depending on alternator specification.

2.8 Alternator Danger Notices

DANGER

Live Electrical Conductors

Live electrical conductors can cause serious injury or death by electric shock and burns. To prevent injury and before working on live conductors:

- *Shut down and isolate the alternator from all energy sources.*
- *Remove or isolate stored energy.*
- *Test isolated parts for electrical isolation using a suitable voltage tester.*
- *Use lock out/tag out safety procedures.*

DANGER

Testing Live Electrical Conductors

Live electrical conductors can cause serious injury or death by electric shock and burns. To prevent injury and before testing on or near live electrical conductors:

- *Take applicable precautions to prevent contact with live conductors, refer to: Safety Precautions Chapter.*
- *Test on or near live conductors, only if absolutely necessary.*
- *Only trained personnel may test on or near live electrical conductors.*
- *Do not test on or near live electrical conductors alone: Another competent person must be present, trained to isolate energy sources and take action in an emergency.*

DANGER

Rotating Mechanical Parts

Rotating mechanical parts can cause serious injury or death by crushing, severing or trapping. To prevent injury:

- *Before operating the alternator: The rotating coupling between the alternator and prime mover must be covered by a guard or cover.*
- *Before attempting service or maintenance tasks or removing covers from rotating parts: Shut down and isolate the generator set from all energy sources, isolate stored energy and use lock out/tag out safety procedures.*

DANGER

Testing on Rotating Mechanical Parts

Rotating mechanical parts can cause serious injury or death by crushing, severing and trapping. To prevent injury and before removing safety covers for testing:

- *Take applicable precautions to prevent contact with uncovered rotating mechanical parts, refer to Safety Precautions Chapter.*
- *Test on or near uncovered rotating mechanical parts, only if absolutely necessary.*
- *Do not test on or near uncovered rotating mechanical parts alone: Additional personnel must be present, who know how to isolate energy sources and take action in an emergency.*

⚠ DANGER

Falling Mechanical Parts

Falling mechanical parts can cause serious injury or death by impact, crushing, severing or trapping. To prevent injury or death and before lifting:

- **Check the capacity, condition and attachment of lifting equipment.**
- **Check the capacity, condition and attachment of accessories for lifting.**
- **Check the capacity, condition and attachment of lifting point(s) on the load.**
- **Check the mass, integrity and stability of the load.**
- **If available: Install drive end and non-drive end transit fittings to prevent movement and damage to bearings.**
- **Keep the alternator horizontal when lifting.**
- **Do not use alternator lifting points for lifting a complete generator set.**
- **Do not use cooler lifting points for lifting the alternator or a complete generator set.**
- **Do not remove the lifting label attached to one of the lifting points.**

2.9 Alternator Warning Notices

⚠ WARNING

Enclosures

Alternators may be installed within an enclosure for environmental protection, noise reduction or transportation reasons. Before entering the enclosure to prevent injury or death, personnel must:

- **Know the related hazards / risks.**
- **Have a safe access route in to and out of the enclosure, have sufficient ventilation and obey the alternator hazard zones.**
- **Wear the appropriate protective equipment.**

Additionally when working with Medium or High Voltage alternators:

- **Enter the enclosure when the alternator is operating, only if absolutely necessary.**
- **To minimize risks to personnel use remote diagnostic, monitoring and measuring systems.**

⚠ WARNING

Terminal Box

Do not modify the terminal box panels or terminal box internal components. Modification(s) can lead to short-circuits or arc-flash events and cause injury or death by electric shock or burns. To prevent injury:

- **Refer to: Arc-Flash warning in the Safety Precaution Chapter.**
- **Contact STAMFORD | AvK™ customer services (www.stamford-avk.com) for guidance before making modifications to the terminal box panels or internal components.**

⚠ WARNING

Arc-flash

An arc-flash event within the terminal box, on the alternator windings or at the cables exiting the terminal box can cause serious injury or death by: Noise, burns, impact from flying/molten debris and/or hot gases. To prevent injury or death from arc-flash:

- **Do not approach the alternator during operation unless wearing appropriate personal protective equipment, refer to: Personal Protective Equipment Paragraph.**
- **Personnel working close an operating alternator must be trained in arc-flash hazard awareness, refer to Training Paragraph.**

An arc-flash is a phenomenon where a flashover of electric current leaves its intended path and travels through the air from one conductor to another, or to ground. Arc-flash can be caused by many things, such as: material failure, corrosion, or incorrect installation.

It is the responsibility of the installer/operating company to do a risk assessment of arc-flash hazard as part of the complete installation, including connection to other energy sources.

Arc-flash hazards can include: Intense noise, hot and rapidly expanding gases, expanding pressure wave, flying debris (including molten copper) and exposure to intense UV light.

When the alternator is connected to other energy sources, the arc-flash can exceed an arc-flash produced by an individual alternator. These additional energy sources can be electrical loads that store energy (e.g. Transformers, capacitors etc.), alternators in parallel or coupled to a mains network.

While arc-flash in an alternator is rare, it is important that the installer/operating company takes applicable measures to ensure the safety of personnel. In accordance with local electrical safe working practices, personnel working around the running alternator must be trained in and aware of arc-flash hazards. Personal protective equipment must be worn when working within the vicinity of the alternator, refer to: Safety Precautions Chapter [Section 2.5 on page 4](#).

Medium Voltage and High Voltage Alternators

Medium voltage and high voltage alternators can be fitted with additional warning and information stickers. Pressure relief vent(s) can be installed in the terminal box. The pressure relief vent(s) can vary from the one shown in the figure below).

If installed, make sure the pressure relief vent(s) are secure and serviceable. Do not remove, obstruct or apply a load to the pressure relief vent(s).



FIGURE 3. ARC-FLASH IMAGES

⚠ WARNING

Condensed Water

Operating an alternator with condensed water in the windings can cause serious injury by electric shock, burns or exposure to flying debris and particles. To prevent injury and before operating the alternator:

- **Use anti-condensation heaters (if fitted) to prevent condensation accumulating.**
- **Check for condensed water.**
- **If condensed water is present, drain/remove the water, dry and inspect the alternator, refer to: Maintenance and Servicing Chapter.**

⚠ WARNING

Coupling an Alternator

Moving mechanical parts during coupling can cause serious injury by crushing, severing or trapping. When coupling the alternator to a prime-mover or when installing large components, to prevent injury:

- **Personnel must keep limbs and body parts away from coupling surfaces during coupling and/or installing operations.**

⚠ WARNING

Hazardous Operating Environments (Explosive Atmospheres)

The use of the alternators in an explosive atmosphere can cause serious injury or death by burns and / or flying debris, particles and fumes. To prevent injury or death:

- **Do not install or operate the alternator where the surrounding atmosphere is potentially explosive.**

⚠ WARNING

Hot Surfaces and Fire

Contact with hot surfaces can cause serious injury and death by burns. A risk of fire exists where hot surfaces are contacted by combustible items. To prevent injury, death or risk of fire:

- **Avoid contact with hot surfaces.**
- **Always wear the appropriate personal protection equipment, refer to: Safety Precaution Chapter.**
- **Make sure combustible materials or flammable substances are not stored close to or contact the anti-condensation heater (if fitted).**
- **Make sure combustible materials or flammable substances are not stored close to the alternator or prime mover, including the ventilation and exhaust system(s) where applicable.**

⚠ WARNING

Noise

Noise from a running alternator can cause serious and permanent hearing damage. To prevent injury:

- **Always wear appropriate personal protection equipment. Refer to Personal Protective Equipment paragraph.**

⚠ WARNING

Incorrect Electrical Installation and System Protection

Incorrect electrical installation and / or system protection can cause serious injury or death by electric shock and burns. To prevent injury or death and before starting work, personnel:

- *Have completed related, applicable and approved training.*
- *Know the equipment, understand the task(s) and procedure(s).*
- *Know related hazards / risks.*
- *Know and obey site / location specific emergency procedures and applicable laws and regulations.*

⚠ WARNING

Live Electrical Conductors

Live electrical conductors at the winding terminals can cause serious injury or death by electric shock or burns. After an insulation resistance test, to prevent injury or death:

- *Discharge the windings immediately after the test has concluded by shorting to a suitable earth. The windings must discharge for the greater of:*
 1. *A length of time equal to the duration of the test.*
or
 2. *5 minutes.*

⚠ WARNING

Grounding

Incorrectly grounded alternators can cause serious injury or death or serious equipment damage by electric shock or electrical malfunction. To avoid equipment damage, injury or death:

- *The alternator must be permanently grounded, unless the application or applicable laws and regulations do not permit alternator grounding.*

⚠ WARNING

Reconnected Energy Source

Accidental reconnection of energy sources during service and maintenance work can cause serious injury or death by electric shock, burns, crushing, severing or trapping. To prevent injury and before starting any service and maintenance work:

- *Isolate the alternator from energy sources.*
- *Prevent alternator use with lock out/tag out safety procedures.*
- *Do not defeat or bypass the lock out/tag out safety procedures.*

⚠ WARNING

Strong Magnetic Field

The strong magnetic field from a Permanent Magnet Generator (PMG) or Excitation Boost System (EBS), can cause serious injury or death by interference with implanted medical devices. To prevent injury or death:

- *Do not work near a Permanent Magnet Generator (PMG) or Excitation Boost System (EBS) if you have an implanted medical device.*

⚠ WARNING

Incorrect or Improper Use

Incorrect or improper use of the alternator may result in equipment damage, serious injury or death. To prevent or equipment damage injury or death:

- **Always select the correct specification alternator for the intended use and application.**
- **Make sure the alternator and prime mover are compatible and suitable for the intended application.**
- **Always install the alternator in accordance with the original manual(s) and technical drawing(s) supplied with the alternator.**
- **Obey locally applicable rules and regulations.**
- **Make sure the alternator is operated in accordance with the manual(s) and within the limits of the alternator rating plate.**
- **Do not use a damaged or defective alternator.**

If a defect(s) is discovered:

- **Shut down and isolate the alternator from all energy sources.**
- **Remove or isolate stored energy.**
- **Use lock out / tag out safety procedures.**
- **Prevent further use of the alternator until it is repaired and returned to a serviceable condition.**

⚠ WARNING

Removing Safety Covers

A hazard exists when alternator safety covers are removed. Ejected debris and particles can cause serious injury or death by impact, severing or puncturing. Exposure to mechanically driven release of debris and particles exists in all directions (horizontally and vertically) where covers are removed. To prevent injury or death:

- **Fit the safety labels at the locations shown on the back of the label sheet supplied.**
- **Observe the safety labels.**
- **Refer to the service manual before removing covers.**



FIGURE 4. SAFETY LABEL

⚠ WARNING

Exposure to Ejected Debris and Particles

Ejected debris and particles can cause serious injury or death by impact, severing or puncturing. Exposure to mechanically driven release of debris and particles exists in all directions (horizontally and vertically) in the areas surrounding the alternator air outlet(s), air inlets(s) and the open shaft end (also commonly known as the Drive End (DE)). To prevent injury or death:

- *Keep away from the air inlet(s) and air outlet(s) when the alternator is operating.*
- *Do not position operator controls near the air inlet(s) or air outlet(s).*
- *Do not cause overheating by running the alternator outside rating plate parameters.*
- *Do not overload the alternator.*
- *Do not operate an alternator displaying excessive vibration.*
- *Do not synchronize parallel alternators outside the specified parameters.*

⚠ WARNING

Exposure to Particles and Fumes from an Alternator.

Particles and fumes can be released in all directions (horizontally and vertically) from where alternator ventilation is installed. To avoid or injury:

- *Avoid the areas around ventilation openings, air intake(s) and air outlet(s) when the alternator is operating.*
- *Use the correct personal protective equipment when working around an alternator.*

⚠ WARNING

Exposure to Particles and Fumes from Alternator Terminal Boxes.

Particles and fumes can be released in all directions (horizontally and vertically) from where terminal box pressure release flap(s) are installed. Terminal box pressure release flap(s) can be located at different positions and orientations. To avoid or injury:

- *Personnel must keep away from terminal box pressure release flap(s) during alternator operation.*

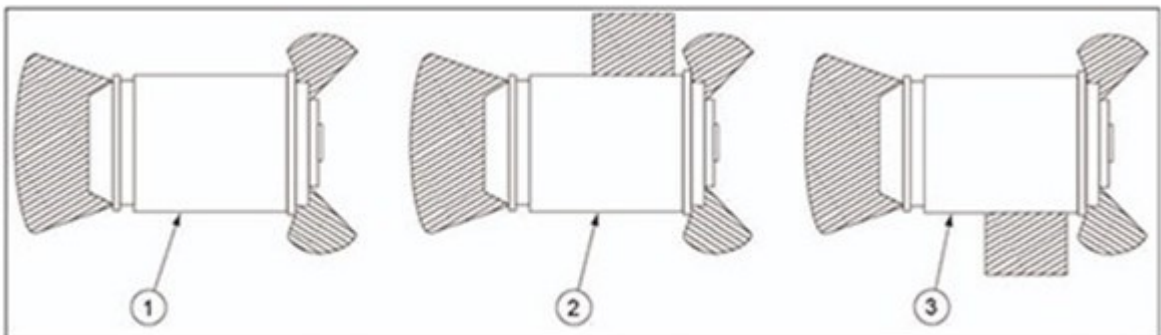

FIGURE 5. S9 ALTERNATOR HAZARD ZONES

2.11 Alternator Caution Notices

 CAUTION

Hazardous Substances

Hazardous substances can cause minor or moderate injury. Prolonged or repetitive exposure to hazardous substances can cause serious medical conditions. To prevent injury:

- **Always read and obey the instructions provided by the product manufacturer.**
- **Use, handle and store substances as specified by the product manufacturer.**
- **Always wear appropriate personal protective equipment, refer to Safety Precautions Chapter.**

 CAUTION

Missing Walkways and Handrails

Walkways and handrails temporarily removed for service and maintenance access can cause minor or moderate injury by slips, trips and falls. To prevent injury and before starting work:

- **Assess the hazards and risks, take applicable precautions for safe working, place warnings and prevent access by unauthorized persons.**

 CAUTION

Dust & Airborne Particles/Fumes

Dust and other airborne particles and fumes can cause minor or moderate injury by irritating the lungs and eyes. Prolonged or repetitive exposure can cause serious medical conditions. To prevent injury:

- **Use mechanical vacuum extraction to remove dust and airborne particles or fumes.**
- **Ventilate the area fully.**
- **Always wear the appropriate personal protective equipment. Refer to Safety Precautions Chapter.**

3 Safety Directives and Standards

3.1 General

STAMFORD® and AvK® alternators meet applicable national and international directives and standards relevant to alternators. The alternator must be operated within the limits specified in the relevant standards and within the parameters on the alternator rating plate. The alternator must comply with the regulatory requirements of the area/territory it is installed and used within.

Marine alternators meet the requirements of all the major marine classification societies.

This chapter includes EU/UK declaration template examples, where and if applicable.

Where necessary, STAMFORD® and AvK® alternators are supplied with a declaration certificate that displays the product description and unique serial number.

3.2 Machinery Directive: Declaration of Incorporation (>1kV)

This "Declaration of Incorporation of Partly Completed Machinery" applies to STAMFORD® and AvK® medium and high voltage alternators producing >1kV.

**2006/42/EC MACHINERY DIRECTIVE
DECLARATION OF INCORPORATION
OF PARTLY COMPLETED MACHINERY**



**ESSENTIAL HEALTH AND SAFETY REQUIREMENTS RELATING TO THE DESIGN
AND CONSTRUCTION OF PARTLY COMPLETED MACHINERY**

<p>1.1 General Remarks</p> <ul style="list-style-type: none"> ▪ 1.1.2 : Principles of safety integration ▪ 1.1.3 : Materials and products ▪ 1.1.5 : Design of machinery to facilitate its handling <p>1.3 Protection Against Mechanical Hazards</p> <ul style="list-style-type: none"> ▪ 1.3.1 : Risk of loss of stability ▪ 1.3.2 : Risk of break-up during operation ▪ 1.3.3 : Risks due to falling or ejected objects ▪ 1.3.4 : Risks due to surfaces, edges or angles ▪ 1.3.7 : Risks related to moving parts ▪ 1.3.8.1 : Moving transmission parts <p>1.4 Guarding *</p> <ul style="list-style-type: none"> ▪ 1.4.1 : Guards – General requirements * ▪ 1.4.2.1 : Fixed guards * <p>1.5 Other Hazards</p> <ul style="list-style-type: none"> • 1.5.2 : Static electricity • 1.5.3 : Energy supply other than electric • 1.5.4 : Errors of fitting • 1.5.6 : Fire • 1.5.13 : Emissions of hazardous materials and substances <p>1.7 Information</p> <ul style="list-style-type: none"> • 1.7.1 : Information and warnings on the machinery • 1.7.4 : Instructions 	<p style="text-align: center;">LEGEND</p> <ol style="list-style-type: none"> 1. Essential Health and Safety Requirements not shown are not considered applicable for this Partly Completed Machinery or must be fulfilled by the assembler of the Machinery. 2. Essential Health and Safety Requirements shown are considered applicable for this Partly Completed Machinery and have been fulfilled by the manufacturer to the extent possible, subject to the build requirements of the Machinery assembler, the information contained in the assembly instructions and Cummins bulletins. 3. * Customers may request Partly Completed Machinery without some or all guarding attached. In these cases section 1.4 Guarding does not apply and the Essential Health and Safety Requirements for guarding must be fulfilled by the assembler of the Machinery.
--	---

FIGURE 7. DECLARATION OF INCORPORATION (>1KV) - SHEET 2

**SUPPLY OF MACHINERY (SAFETY)
REGULATIONS 2008
DECLARATION OF INCORPORATION
OF PARTLY COMPLETED MACHINERY**



Function: Synchronous A.C. generator > 1000VAC designed for incorporation into an electricity generating-set.

The partly completed machinery supplied with this declaration:

- Is designed and constructed solely as a non-functional component to be incorporated into a machine requiring completion.
- Is designed to comply with the provisions of the following EU Directives so far as their level of build will allow:

S.I. 2016/1091 The Electromagnetic Compatibility Regulations

- Must not be put into service within the UK until the final machinery into which it is to be incorporated has been declared in conformity with the Supply of Machinery (Safety) Regulations 2008 and all other applicable UK Statutory Instruments.
- Is designed and constructed to comply with the essential health and safety requirements of the Supply of Machinery (Safety) Regulations 2008 listed on sheet 2 of this Declaration.

The relevant technical documentation is compiled in accordance with the provisions of part B of Annex VII of the Machinery Directive. All relevant information about the partly completed machinery will be provided, in writing, on a reasoned request by the appropriate national authority to its authorised representative. The name and address of authorised representative, authorised to compile the relevant technical documentation, is the Company Secretary, Cummins Generator Technologies, Fountain Court, Lynch Wood, Peterborough, UK. PE2 6FZ

The undersigned representing the manufacturer:

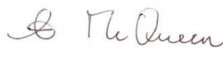
<p>Signed:</p>  <p>Date: 4th August 2021</p>	<p>Name, Title and Address:</p> <p>Alastair McQueen Global Technical Director Cummins Generator Technologies Fountain Court, Lynch Wood Peterborough, UK PE2 6FZ</p>
--	--

Description:

Serial Number:

FIGURE 8. DECLARATION OF INCORPORATION (>1KV) - SHEET 3

**SUPPLY OF MACHINERY (SAFETY)
REGULATIONS 2008
DECLARATION OF INCORPORATION
OF PARTLY COMPLETED MACHINERY**



**ESSENTIAL HEALTH AND SAFETY REQUIREMENTS RELATING TO THE DESIGN AND
CONSTRUCTION OF PARTLY COMPLETED MACHINERY**

<p>General Remarks</p> <ul style="list-style-type: none"> ▪ 1.1.2 : Principles of safety integration ▪ 1.1.3 : Materials and products ▪ 1.1.5 : Design of machinery to facilitate its handling <p>Protection Against Mechanical Hazards</p> <ul style="list-style-type: none"> ▪ 1.3.1 : Risk of loss of stability ▪ 1.3.2 : Risk of break-up during operation ▪ 1.3.3 : Risks due to falling or ejected objects ▪ 1.3.4 : Risks due to surfaces, edges or angles ▪ 1.3.7 : Risks related to moving parts ▪ 1.3.8.1 : Moving transmission parts <p>Guarding *</p> <ul style="list-style-type: none"> ▪ 1.4.1 : Guards – General requirements * ▪ 1.4.2.1 : Fixed guards * <p>Other Hazards</p> <ul style="list-style-type: none"> • 1.5.2 : Static electricity • 1.5.3 : Energy supply other than electric • 1.5.4 : Errors of fitting • 1.5.6 : Fire • 1.5.13 : Emissions of hazardous materials and substances <p>Information</p> <ul style="list-style-type: none"> • 1.7.1 : Information and warnings on the machinery • 1.7.4 : Instructions 	<p style="text-align: center;"><u>LEGEND</u></p> <ol style="list-style-type: none"> 1 Essential Health and Safety Requirements not shown are not considered applicable for this Partly Completed Machinery or must be fulfilled by the assembler of the Machinery. 2 Essential Health and Safety Requirements shown are considered applicable for this Partly Completed Machinery and have been fulfilled by the manufacturer to the extent possible, subject to the build requirements of the Machinery assembler, the information contained in the assembly instructions and Cummins bulletins. 3 * Customers may request Partly Completed Machinery without some or all guarding attached. In these cases section 1.4 Guarding does not apply and the Essential Health and Safety Requirements for guarding must be fulfilled by the assembler of the Machinery.
--	--

FIGURE 9. DECLARATION OF INCORPORATION (>1KV) - SHEET 4

3.3 Additional Information for Electromagnetic Compatibility Compliance (EMC)

Where necessary STAMFORD® and AvK® alternators are designed to meet electromagnetic compatibility compliance emissions and immunity standards for industrial environments. Additional equipment may be required when the alternator is installed in residential, commercial, and light industrial environments.

The installation 'earth/ground' arrangements require the connection of the alternator frame to the site protective earth conductor using a minimum lead length.

NOTICE

Cummins Generator Technology is not liable for electromagnetic compatibility compliance if non-genuine STAMFORD® or AvK® brand parts are used for maintenance, servicing or repairs.

3.4 Additional Information for Canadian Standards Association (CSA)

To comply with Canadian Standards Association (CSA) regulations, all external wiring and components must be rated to: At least the alternator rated voltage shown on the alternator rating plate.

4 Introduction

4.1 General Description

S9 alternators are of brushless rotating field design, available in the following ranges:

- Low Voltage (LV) up to 1000 V, 50 Hz (1500 RPM, 4 pole) and 1000 V, 60 Hz (1800 RPM, 4 pole).
- Medium Voltage (MV) up to 3.3 kV, 50 Hz (1500 RPM, 4 pole) and 4.16 kV, 60 Hz (1800 RPM, 4 pole).
- High Voltage (HV) up to 13.8 kV, 50 Hz (1500 RPM, 4 pole) and 13.8 kV, 60 Hz (1800 RPM, 4 pole).

S9 alternators have an excitation system that uses various AVR's powered by a Permanent Magnet Generator (PMG).

4.2 Noise

 WARNING
<p>Noise Noise from a running alternator can cause serious and permanent hearing damage. To prevent injury:</p> <ul style="list-style-type: none"> • Always wear appropriate personal protection equipment. Refer to Personal Protective Equipment paragraph.

Maximum A-weighted noise emissions may reach 110 dB(A). Contact the supplier for application-specific details.

4.3 Alternator Name

TABLE 2. S9 ALTERNATOR NAMING FORMAT

Example:	S	9	L	1	D	-	C	4	2
	STAMFORD Brand	Family Series	Voltage (L=low, M = medium, H = high)	Revision	Descriptor D = Dedicated, M = Marine		Core length (A, B, C, D, E, ...)	Number of poles	Number of bearings (1 = NDE, 2 = DE & NDE)

4.4 Serial Number Location

A unique serial number is stamped on the side of the stator frame and shown on two labels on the outside of the terminal box.

4.5 Rating Plate

The self-adhesive rating plate label, supplied with the alternator, must be fixed after the generator set is fully assembled and painted.

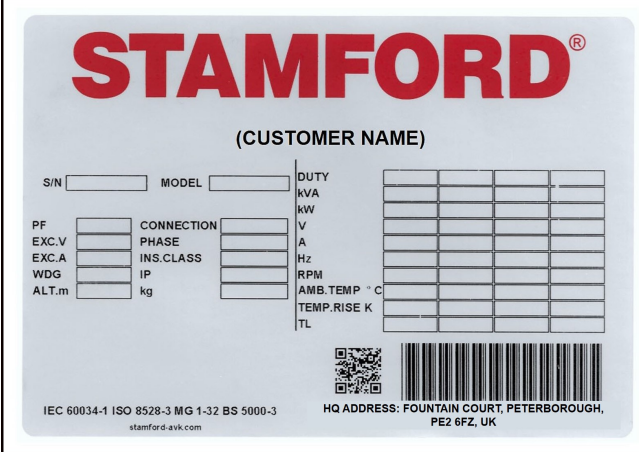

The rating plate is a rectangular label with a light blue background. At the top, the word "STAMFORD" is printed in large, bold, red letters with a registered trademark symbol. Below it, the text "(CUSTOMER NAME)" is centered. The plate is divided into several sections for technical specifications. On the left, there are fields for S/N, MODEL, PF, EXC.V, EXC.A, WDG, and ALT.m. In the middle, there are fields for CONNECTION, PHASE, INS.CLASS, and IP. On the right, there are fields for DUTY, kVA, kW, V, A, Hz, RPM, AMB. TEMP °C, TEMP.RISE K, and TL. A QR code and a barcode are located at the bottom right. At the bottom left, the text "IEC 60034-1 ISO 8528-3 MG 1-32 BS 5000-3" and "stamford-avk.com" are printed. At the bottom right, the HQ address "FOUNTAIN COURT, PETERBOROUGH, PE2 6FZ, UK" is printed.

FIGURE 10. GLOBAL STAMFORD ALTERNATOR RATING PLATE

4.6 Product Authentication

The STAMFORD | AvK™ high security, anti-counterfeit hologram is located on the Tracking Label. Check that the dots are visible around the logo when viewing the hologram from different angles and the word "GENUINE" appears behind the logo. Use a flashlight to see these security features in low ambient light. Check that the alternator is genuine by entering the unique 7 character hologram code at www.stamford-avk.com/verification.

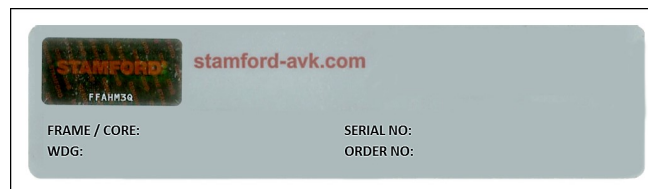

FIGURE 11. TRACKING LABEL

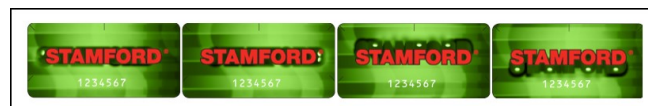

FIGURE 12. DOTS VISIBLE IN LEFT, RIGHT, UPPER AND LOWER VIEWS OF 3D HOLOGRAM

5 Lifting, Storage and Transportation

5.1 General Transport Guidance

Alternators vary in shape, size, weight, and center of gravity. For product information, refer to the general arrangement drawing, lifting label and transport information supplied with the alternator.

Before loading a vehicle, transporting a load and/or unloading a vehicle:

- Obey applicable rules and regulations relating to transport operations at all times.
- Make sure a sufficient number of applicably configured restraints are used to lash down/secure an alternator to a vehicle.
- Do not position lashing down/securing restraints on or over sensitive components that can be damaged by the restraint.
- Do not position lashing down/securing restraints on paintwork or information/warning labeling. Protect these areas if restrains must be placed over them.
- Before transportation or storage, apply an anti-corrosion agent to exposed machined surfaces.
- Before transportation or storage, cover exposed connection points with a sufficient cover, cap or packaging material.
- Before transportation or storage, if necessary, protect bearings from vibration using anti-vibration pads. Do not transport unprotected alternators over an uneven surface.
- Alternators should be supplied on a transport frame if necessary.
- Bearings should be protected from damage by using a transportation lock (if available) when necessary. If a transport lock is supplied with the bearing/alternator it must be installed before transportation.
- Read and obey industry best practice guidance.
- Consult with a transport specialist for advice if necessary.

5.2 Lifting the Alternator

DANGER

Falling Mechanical Parts

Falling mechanical parts can cause serious injury or death by impact, crushing, severing or trapping. To prevent injury or death and before lifting:

- ***Check the capacity, condition and attachment of lifting equipment.***
- ***Check the capacity, condition and attachment of accessories for lifting.***
- ***Check the capacity, condition and attachment of lifting point(s) on the load.***
- ***Check the mass, integrity and stability of the load.***
- ***If available: Install drive end and non-drive end transit fittings to prevent movement and damage to bearings.***
- ***Keep the alternator horizontal when lifting.***
- ***Do not use alternator lifting points for lifting a complete generator set.***
- ***Do not use cooler lifting points for lifting the alternator or a complete generator set.***
- ***Do not remove the lifting label attached to one of the lifting points.***

Lift the alternator by shackles attached to the lifting points (lugs or eyes) provided. A label attached to a lifting point shows the correct lifting arrangement. Use chains of sufficient length, and a spreader bar if necessary, to make sure that the chains are vertical when lifting. Make sure that the capacity of the lifting equipment is sufficient for the alternator mass shown on the label attached to the alternator.

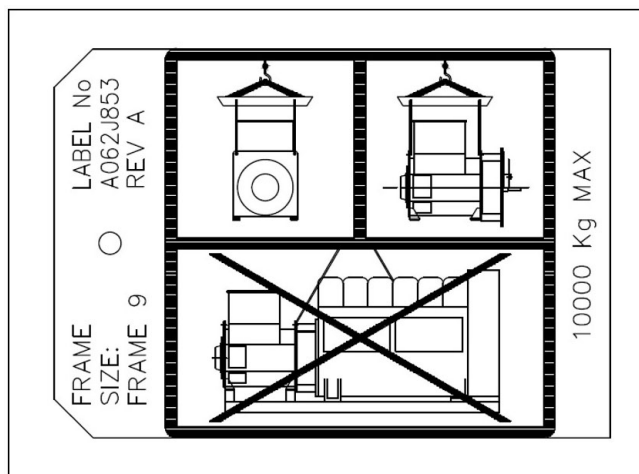

FIGURE 13. EXAMPLE LIFTING LABEL

5.3 Alternator Dimensions

Dimensions are included in the data sheet specific to the alternator model. Refer to the rating plate to identify the alternator model.

NOTICE

Data sheets are available from www.stamford-avk.com

5.4 Storage

⚠ WARNING

Condensed Water

Operating an alternator with condensed water in the windings can cause serious injury by electric shock, burns or exposure to flying debris and particles. To prevent injury and before operating the alternator:

- **Use anti-condensation heaters (if fitted) to prevent condensation accumulating.**
- **Check for condensed water.**
- **If condensed water is present, drain/remove the water, dry and inspect the alternator, refer to: Maintenance and Servicing Chapter.**

⚠ WARNING

Hot Surfaces and Fire

Contact with hot surfaces can cause serious injury and death by burns. A risk of fire exists where hot surfaces are contacted by combustible items. To prevent injury, death or risk of fire:

- **Avoid contact with hot surfaces.**
- **Always wear the appropriate personal protection equipment, refer to: Safety Precaution Chapter.**
- **Make sure combustible materials or flammable substances are not stored close to or contact the anti-condensation heater (if fitted).**
- **Make sure combustible materials or flammable substances are not stored close to the alternator or prime mover, including the ventilation and exhaust system(s) where applicable.**

If the alternator will not be used immediately, it must be stored in a clean, dry, vibration-free environment. We recommend the use of anti-condensation heaters, when available.

If the alternator can be rotated, turn the rotor a minimum of 6 revolutions every month during storage.

5.5 Long-term Storage

When an alternator is stationary, in storage or otherwise, it may be subjected to environmental factors, such as vibration, humidity, temperature and airborne contaminant particles, that could degrade the bearing arrangements.

Contact STAMFORD | AvK™ customer services www.stamford-avk.com for advice in advance if the alternator will be stationary for long periods.

5.6 After Storage

After a period of storage, do the pre-running checks to determine the condition of the windings. If the windings are damp or the insulation resistance is low, refer to insulation drying procedures: [Chapter 8 on page 45](#).

Before putting the alternator into service, refer to the following table.

TABLE 3. BEARING STORAGE

	Not Rotated during Storage	Rotated during Storage
Re-greasable Bearing(s)	If stored less than 6 months, put the alternator into service. If stored between 6 to 12 months, re-grease the bearings(s) during the first run then put the alternator into service. If stored more than 12 months, replace the bearing(s) then put the alternator into service.	If stored less than 6 months, put the alternator into service. If stored between 6 and 24 months, re-grease the bearing(s) during the first run then put the alternator into service. If stored more than 24 months, replace the bearing(s) then put the alternator into service.

5.7 Rotor Transit Support

5.7.1 Two Bearing Rotor Transit Support

Two bearing alternators can be supplied with optional, factory-fitted rotor transit support screws that are installed on the non-drive end section of the alternator. The transit support screws provide additional protection against false brinelling (flats on the balls and grooves on the races of the alternator bearings) caused by vibrations during transport.

If transit support screws are supplied:

- They should be installed on the alternator before transportation.
- They must be removed before rotating, during coupling or operating the alternator. Replace the transit screws with the supplied blanking screws for ingress protection.
- They should be stored in a safe location for future use.
- During storage, the transit support screws must be removed (if fitted) for maintenance so the alternator can turn freely.

NOTICE

Failure to remove the transit support screws before rotating, during coupling or operating the alternator could result in damage to the alternator or coupled generator set.

Removal

1. Remove the air inlet cover by loosening the 14 x M8 bolts to gain access to the rotor transit support screws. Refer to: [Figure 14 on page 25](#).
2. Once access is gained to the transit screws, loosen the screws using the following sequence:
 - Top screws: One quarter turn.
 - Bottom screws: One quarter turn.
 - Repeat the above steps until the screws are loose. They can then be removed.
3. Remove the screws and retain for future use.
4. Replace the transit support screws with the 4 accompanied blanking screws and tighten to 50 Nm. Refer to: [Figure 15 on page 25](#).
5. Replace the air inlet cover and tighten the screws to 10 Nm.
6. Before running the alternator ensure the rotor turns freely. ¹

Installation

1. Remove the air inlet cover to gain access to the rotor transit support blanking screws. Refer to: [Figure 14 on page 25](#).
2. Locate and remove the 4 blanking screws on the non-drive end bearing cap. Refer to: [Figure 15 on page 25](#).
3. For additional protection, apply threadlocker adhesive (such as Loctite 243) to the transit support screws. Install the 4 transit support screws in the following sequence.
 - Begin with all screws finger tight
 - Tighten lower screws to 20 Nm
 - Tighten upper screws to 20 Nm
 - Tighten lower screws to 40 Nm
 - Tighten upper screws to 40 Nm
 - Tighten lower screws to 50 Nm

¹ Rotate the alternator in a clockwise direction when facing the drive end section unless otherwise stated.

-
- Tighten upper screws to 50 Nm
4. Replace the NDE air inlet cover and tighten the 14 x M8 bolts to 10 Nm.

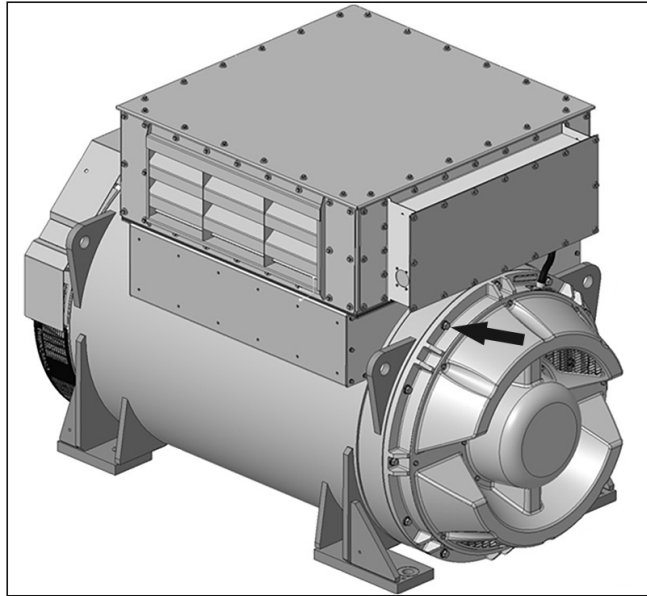

FIGURE 14. AIR INLET COVER REMOVAL AND FITTING INSTRUCTIONS

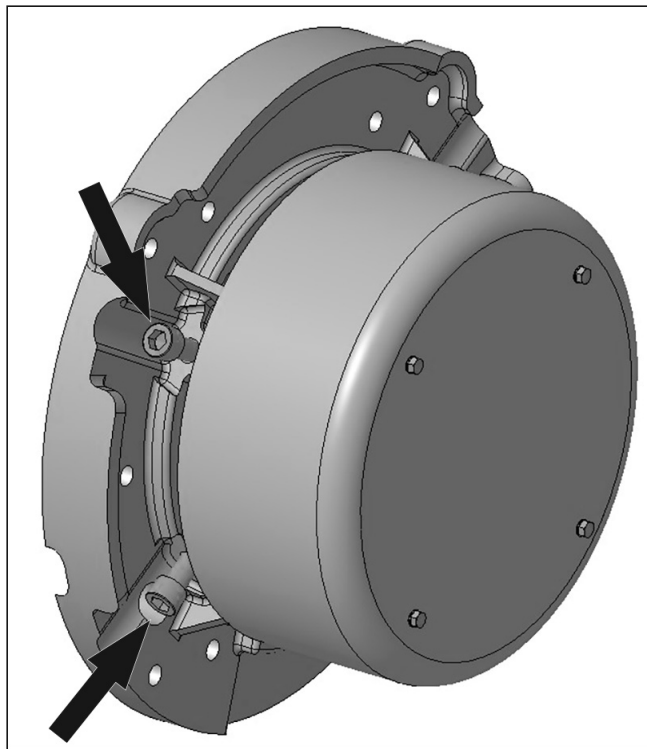



FIGURE 15. ROTOR TRANSIT SUPPORT SCREWS REMOVAL AND FITTING INSTRUCTIONS

-

This page is intentionally blank.

6 Application of the Alternator

It is the customer's responsibility to make sure that the selected alternator is suitable for the final application.

 WARNING	
<i>Incorrect or Improper Use</i>	
<i>Incorrect or improper use of the alternator may result in equipment damage, serious injury or death. To prevent or equipment damage injury or death:</i>	
<ul style="list-style-type: none">• <i>Always select the correct specification alternator for the intended use and application.</i>• <i>Make sure the alternator and prime mover are compatible and suitable for the intended application.</i>• <i>Always install the alternator in accordance with the original manual(s) and technical drawing(s) supplied with the alternator.</i>• <i>Obey locally applicable rules and regulations.</i>• <i>Make sure the alternator is operated in accordance with the manual(s) and within the limits of the alternator rating plate.</i>• <i>Do not use a damaged or defective alternator.</i>	
<i>If a defect(s) is discovered:</i>	
<ul style="list-style-type: none">• <i>Shut down and isolate the alternator from all energy sources.</i>• <i>Remove or isolate stored energy.</i>• <i>Use lock out / tag out safety procedures.</i>• <i>Prevent further use of the alternator until it is repaired and returned to a serviceable condition.</i>	

6.1 Environment

The alternators are protected to IP23 as standard. IP23 is not adequate protection for use outdoors without additional measures.

TABLE 4. ENVIRONMENTAL SPECIFICATION

Ambient Temperature	-15 °C to 40 °C (5 °F to 104 °F)
Relative Humidity	< 70%
Altitude	< 1000 m (3280 ft)

The alternator has been designed for the environment shown in the table. The alternator can operate outside these conditions in some circumstances. Please contact the applications department applications@cummins.com for details. If the operating environment is changed after purchase, speak to STAMFORD | AvK™ customer services www.stamford-avk.com for a revised alternator rating.

6.2 Air Flow

TABLE 5. S9 LV, MV, HV MINIMUM AIR FLOW AND MAXIMUM PRESSURE DIFFERENCE

Alternator model and frequency	Minimum Air flow, m ³ /s (ft ³ /min)		Maximum intake to outlet pressure difference, mm (in) water gauge
	50 Hz	60 Hz	
S9 (All Variants)	2.78 (5890)	3.33 (7056)	13 (0.5)

Make sure that the air inlets and outlets are not obstructed when the alternator is running.

6.3 Airborne Contaminants

CAUTION

Dust & Airborne Particles/Fumes

Dust and other airborne particles and fumes can cause minor or moderate injury by irritating the lungs and eyes. Prolonged or repetitive exposure can cause serious medical conditions.

To prevent injury:

- ***Use mechanical vacuum extraction to remove dust and airborne particles or fumes.***
- ***Ventilate the area fully.***
- ***Always wear the appropriate personal protective equipment. Refer to Safety Precautions Chapter.***

NOTICE

Contaminants such as salt, oil, exhaust fumes, chemicals, dust, and sand will reduce the effectiveness of the insulation and the life of the windings. Consider using air filters and an enclosure to protect the alternator.

6.4 Air Filters

Air filters trap airborne particulates above 5 microns. The filters must be cleaned or replaced regularly, depending on site conditions. Check the filters frequently to establish an appropriate service interval.

Alternators with factory-fitted filters are rated to account for the reduced flow rate of cooling air. If filters are retrofitted, the alternator rating must be reduced by 5%.

Air filters do not remove water. Keep the filters dry with additional protection. Wet filters further restrict airflow, causing the alternator to overheat and leading to premature failure of the insulation.

6.5 Humid Conditions

The water carrying capacity of air depends on temperature. If the air temperature falls below its saturation point, dew may form on the windings reducing the electrical resistance of the insulation. In humid conditions additional protection may be required, even if the alternator is fitted inside an enclosure. Anti-condensation heaters are fitted as standard.

6.6 Anti-Condensation Heaters

DANGER

Live Electrical Conductors

Live electrical conductors can cause serious injury or death by electric shock and burns. To prevent injury and before working on live conductors:

- *Shut down and isolate the alternator from all energy sources.*
- *Remove or isolate stored energy.*
- *Test isolated parts for electrical isolation using a suitable voltage tester.*
- *Use lock out/tag out safety procedures.*

WARNING

Condensed Water

Operating an alternator with condensed water in the windings can cause serious injury by electric shock, burns or exposure to flying debris and particles. To prevent injury and before operating the alternator:

- *Use anti-condensation heaters (if fitted) to prevent condensation accumulating.*
- *Check for condensed water.*
- *If condensed water is present, drain/remove the water, dry and inspect the alternator, refer to: Maintenance and Servicing Chapter.*

WARNING

Hot Surfaces and Fire

Contact with hot surfaces can cause serious injury and death by burns. A risk of fire exists where hot surfaces are contacted by combustible items. To prevent injury, death or risk of fire:

- *Avoid contact with hot surfaces.*
- *Always wear the appropriate personal protection equipment, refer to: Safety Precaution Chapter.*
- *Make sure combustible materials or flammable substances are not stored close to or contact the anti-condensation heater (if fitted).*
- *Make sure combustible materials or flammable substances are not stored close to the alternator or prime mover, including the ventilation and exhaust system(s) where applicable.*

Power to the anti-condensation heater is supplied from a separate source. Anti-condensation heaters raise the air temperature around the windings to deter condensation forming in humid conditions when the alternator is not operating. Best practice is to energize the heaters automatically when the alternator is off.

6.7 Enclosures

WARNING

Enclosures

Alternators may be installed within an enclosure for environmental protection, noise reduction or transportation reasons. Before entering the enclosure to prevent injury or death, personnel must:

- **Know the related hazards / risks.**
- **Have a safe access route in to and out of the enclosure, have sufficient ventilation and obey the alternator hazard zones.**
- **Wear the appropriate protective equipment.**

Additionally when working with Medium or High Voltage alternators:

- **Enter the enclosure when the alternator is operating, only if absolutely necessary.**
- **To minimize risks to personnel use remote diagnostic, monitoring and measuring systems.**

WARNING

Water ingress during rainy season could lead to electrical shock near alternator, and other electrical components.

- Fit an enclosure to protect the alternator from adverse environmental conditions.
- Make sure that air entering the alternator is of adequate flow rate, free from moisture and contaminants and below the maximum ambient temperature on the rating plate.
- The airflow should be modeled to identify and prevent hot air from re-circulating within the enclosure.
- Make sure there is sufficient access around the alternator for safe maintenance.

6.8 Vibration

The alternators are designed to withstand the vibration levels encountered on generator sets built to meet the requirements of ISO 8528-9 and BS 5000-3. (Where ISO 8528 is taken to be broad band measurements and BS5000 refers to the predominant frequency of any vibrations on the generator set).

NOTICE

Exceeding either of the above specifications will have a detrimental effect on the life of the bearings and other components and may invalidate the alternator warranty.

NOTICE

The terminal box is designed to support the fitted busbars or terminals, transformers, load cables and auxiliary terminal box. Additional mass could cause excessive vibration and lead to failure of the terminal box enclosure and mounting. Refer to the Installation Manual to connect the load cables to the terminal box. Speak to STAMFORD | AvK™ customer services before fixing any additional mass to the terminal box.

6.8.1 Definition of BS5000–3

Alternators shall be capable of continuously withstanding linear vibration levels with amplitudes of 0.25 mm between 5 Hz and 8 Hz, and velocities of 9.0 mm/s RMS between 8 Hz and 200 Hz, when measured at any point directly on the carcass or main frame of the machine. These limits refer only to the predominant frequency of vibration of any complex waveform.

6.8.2 Definition of ISO 8528-9

ISO 8528-9 refers to a broad band of frequencies, the broad band is taken to be between 10 Hz and 1000 Hz. The table below is an extract from ISO 8528-9 (Table C.1, value 1). This simplified table lists the vibration limits by kVA and speed for acceptable operation of standard generator set designs.

6.8.3 Vibration Frequencies

The main vibration frequencies produced by the alternator are as follows:

- 4-pole 1500 RPM 25 Hz
- 4-pole 1800 RPM 30 Hz

Vibrations induced in the alternator by the engine are complex. It is the responsibility of the generator set designer to ensure that the alignment and stiffness of the bedplate and mountings do not allow vibration to exceed BS5000 part 3 and ISO 8528 part 9 limits.

6.8.4 Linear Vibration Limits

TABLE 6. S9 VIBRATION LEVEL MEASUREMENTS

Linear Vibration Levels As Measured On The Alternator - S9			
Engine Speed RPM (min ⁻¹)	Power Output S (kVA)	Vibration Displacement RMS (mm)	Vibration Velocity RMS (mm/s)
1 300 ≤n, ≤2 000	>250	0.32	20
The broad band is taken as 10 Hz - 1000 Hz			

6.8.5 Linear Vibration Monitoring

We recommend using vibration analyzing equipment to measure vibration at the positions shown below. Best practice is for the generator set builder or during early stages of commissioning, take initial vibration readings as a reference. Periodically monitor vibration, according to the recommended service schedule to detect a deteriorating trend. If the vibration values change from the base line or go above the limits specified in ISO 8528-9, the generator set builder should be informed.

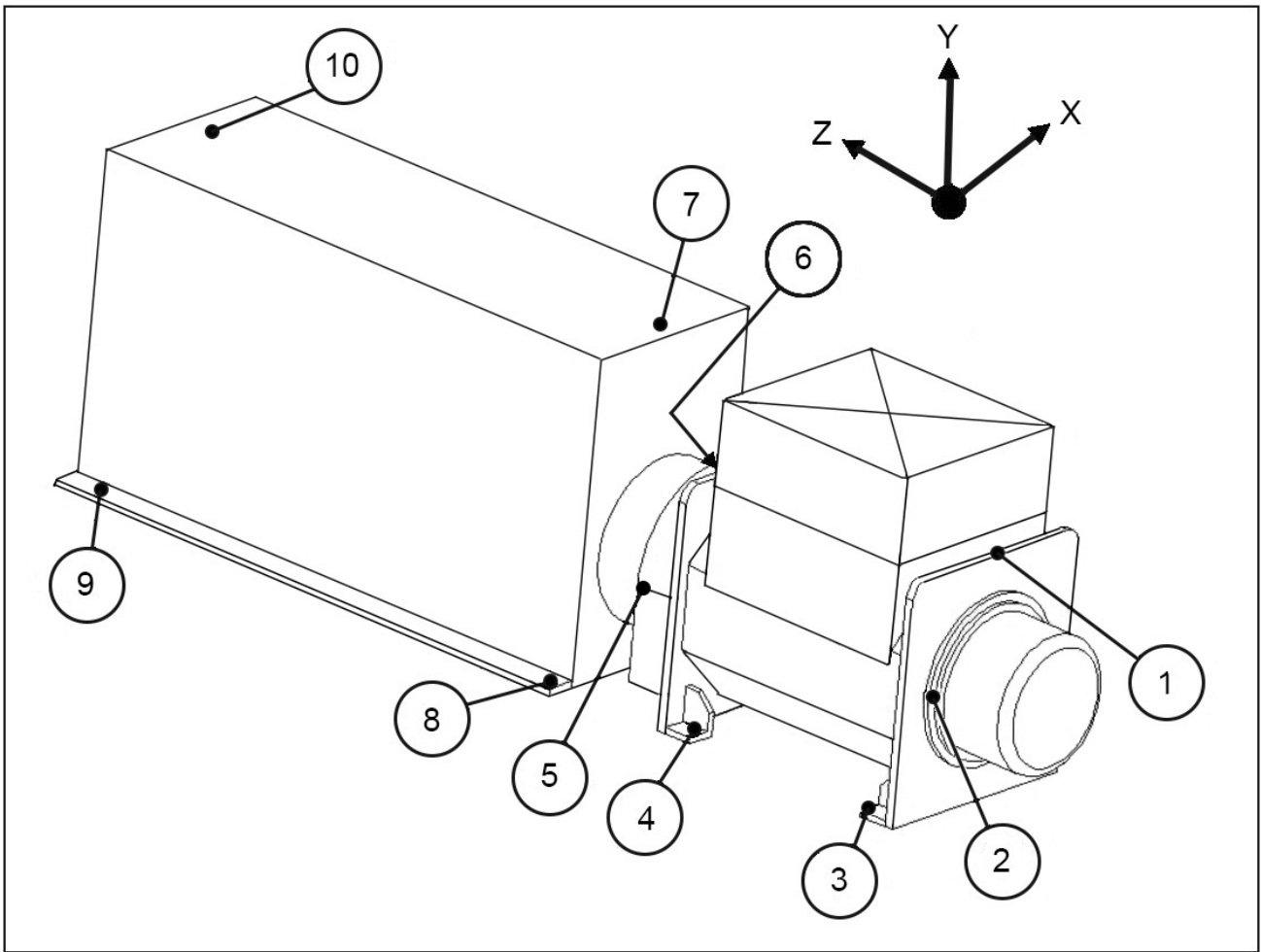

FIGURE 16. VIBRATION MEASUREMENT POSITIONS

6.8.6 Excessive Vibration

⚠ WARNING

Exposure to Ejected Debris and Particles

Ejected debris and particles can cause serious injury or death by impact, severing or puncturing. Exposure to mechanically driven release of debris and particles exists in all directions (horizontally and vertically) in the areas surrounding the alternator air outlet(s), air inlet(s) and the open shaft end (also commonly known as the Drive End (DE)). To prevent injury or death:

- ***Keep away from the air inlet(s) and air outlet(s) when the alternator is operating.***
- ***Do not position operator controls near the air inlet(s) or air outlet(s).***
- ***Do not cause overheating by running the alternator outside rating plate parameters.***
- ***Do not overload the alternator.***
- ***Do not operate an alternator displaying excessive vibration.***
- ***Do not synchronize parallel alternators outside the specified parameters.***

If the measured vibration of the generator set is not within the limits:

1. Consult with the generator set manufacturer to reduce vibration to an acceptable level.
2. Speak to STAMFORD | AvK™ customer services www.stamford-avk.com to assess the impact on bearing and alternator life expectancy.

6.9 Bearings

6.9.1 Re-greasable Bearings

Each bearing housing is connected by a grease pipe to an external grease nipple. A label gives the grease type and quantity, and frequency for re-greasing. The recommended grease is a high specification synthetic compound that must not be mixed with grease of a different specification. Refer to the Service and Maintenance chapter for detailed instructions.

6.9.2 Bearing Life

Factors that reduce bearing life or lead to bearing failure include:

- Adverse operating conditions and environment.
- Stress caused by misalignment of the generator set.
- Vibration from the engine that exceeds the limits in BS 5000-3 and ISO 8528-9.
- Long periods (including transportation) when the alternator is stationary and subjected to vibration can cause false brinelling wear (flats on the balls and grooves on the races).
- Humid or wet conditions that cause corrosion and deterioration of the grease by emulsification.

6.9.3 Health Monitoring of the Bearings

We recommend that the user checks the bearing condition using vibration monitoring equipment. Best practice is to take initial readings as a reference and periodically monitor the bearings to detect a deteriorating trend. It will then be possible to plan a bearing change at an appropriate generator set or engine service interval.

6.9.4 Bearing 'Service Life' Expectancy

Bearing manufacturers recognize that the service life of bearings depends on factors that are outside their control. Rather than quote a service life, practicable replacement intervals are based on the L10 life of the bearing, the type of grease, and the recommendations of the bearing and grease manufacturers.

For general purpose applications, if the correct maintenance is carried out, vibration levels do not exceed the levels stated in ISO 8528-9 and BS5000-3, and the ambient temperature does not exceed 50 °C, plan to replace the bearings within 30,000 hours of operation.

If in doubt regarding any aspect of bearing life of a STAMFORD | AvK™ alternator, contact the nearest authorized supplier of the alternator or STAMFORD | AvK™ customer services www.stamford-avk.com.

6.9.5 Standby Applications

Run alternators in standby applications at no load for a minimum of 10 minutes every week. For alternators fitted with re-greasable bearings, re-grease the bearings every 6 months, regardless of the number of accumulated running hours.

-

This page is intentionally blank.

7 Installation into the Generator Set

7.1 Generator Set Coupling

⚠ WARNING

Coupling an Alternator

Moving mechanical parts during coupling can cause serious injury by crushing, severing or trapping. When coupling the alternator to a prime-mover or when installing large components, to prevent injury:

- *Personnel must keep limbs and body parts away from coupling surfaces during coupling and/or installing operations.*

NOTICE

Do not attempt to rotate the alternator rotor by levering against the vanes of the cooling fan. The fan is not designed to withstand such forces and will be damaged.

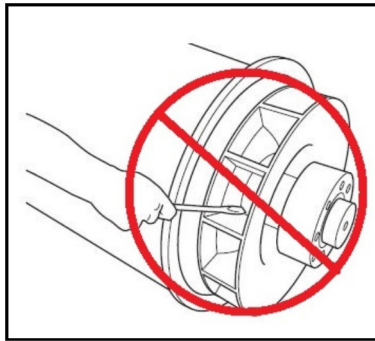

FIGURE 17. DO NOT ROTATE WITH A LEVER

Efficient operation and long component life depend on minimizing mechanical stresses on the alternator. When coupled in a generator set, misalignment and vibration interactions with the prime mover engine can cause mechanical stress.

A coupling mass greater than 150 kg will reduce bearing life significantly. Refer to the factory for further information.

Generator sets need a substantial flat continuous bedplate to suit the installation site floor loading, with engine and alternator mounting pads to make a firm base for accurate alignment. The height of all mounting pads must be within 0.25 mm for skid mounting, 3 mm for non-adjustable anti-vibration mounts (AVM) or 10 mm for adjustable height AVMs. Use shims or adjust alignment elements to achieve level. The rotational axes of alternator rotor and engine output shaft must be coaxial (radial alignment) and perpendicular to the same plane (angular alignment). The axial alignment of the alternator and engine coupling must be within 0.5 mm, to allow for thermal expansion without unwanted axial force on the bearings at operating temperature.

Vibration can occur by flexing of the coupling. The alternator is designed for a maximum bending moment not exceeding 275 kgm (2000 lbs ft). Check the maximum bending moment of the engine flange with the engine manufacturer.

Torsional vibrations occur in all engine-driven shaft systems and may be large enough to cause damage at critical speeds. The generator set builder must consider the effect of torsional vibration on the alternator shaft and couplings, referring to the torsional drawings supplied for shaft dimensions and rotor inertia.

Close-coupling of alternator and engine can increase the rigidity of the generator set. Both one and two bearing alternators can be close-coupled. The generator set builder must supply guarding for open-coupled applications.

To prevent rust during transit and storage, the alternator frame spigot, rotor coupling plates and shaft extension have been treated with a rust preventative coating. Remove this before coupling the generator set.

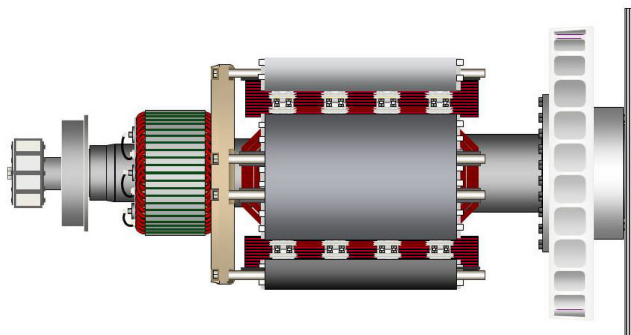

FIGURE 18. ONE BEARING ALTERNATOR ROTOR SHOWING COUPLING DISCS BOLTED TO DRIVE END COUPLING HUB (AT RIGHT)

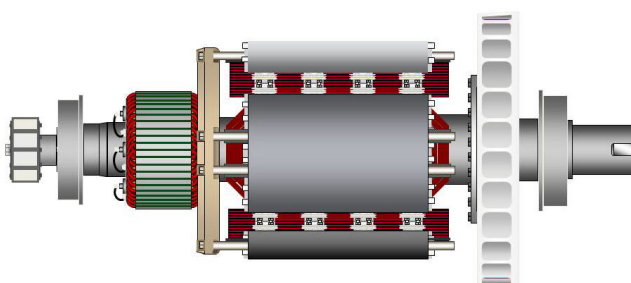

FIGURE 19. TWO BEARING ALTERNATOR ROTOR SHOWING SHAFT WITH KEYWAY FOR FLEXIBLE COUPLING (AT RIGHT)

7.2 One Bearing Alternators

⚠ DANGER

Falling Mechanical Parts

Falling mechanical parts can cause serious injury or death by impact, crushing, severing or trapping. To prevent injury or death and before lifting:

- ***Check the capacity, condition and attachment of lifting equipment.***
- ***Check the capacity, condition and attachment of accessories for lifting.***
- ***Check the capacity, condition and attachment of lifting point(s) on the load.***
- ***Check the mass, integrity and stability of the load.***
- ***If available: Install drive end and non-drive end transit fittings to prevent movement and damage to bearings.***
- ***Keep the alternator horizontal when lifting.***
- ***Do not use alternator lifting points for lifting a complete generator set.***
- ***Do not use cooler lifting points for lifting the alternator or a complete generator set.***
- ***Do not remove the lifting label attached to one of the lifting points.***

1. Check that the bracket which supports the rotor underneath the fan hub is fitted in position.

-
2. Remove the air outlet covers from the drive end of the alternator to access the coupling and adaptor bolts.
 3. Position the alternator close to the engine and remove the drive end transit bracket that keeps the rotor in place during transport.
 4. If required, tighten the coupling disc bolts in the sequence shown in [Figure 20 on page 38](#).
 5. Check the torque of bolts that fasten the coupling discs to the DE coupling hub in a clockwise direction around the bolt circle.
 6. Make sure the coupling discs are concentric with the adaptor spigot. Use alignment studs to ensure that the disc and the flywheel are in alignment.
 7. Make sure the axial distance from the coupling mating face on the flywheel to the mating face on the flywheel housing is within 0.5 mm of nominal dimension. This ensures that the engine crankshaft float is maintained and the alternator rotor position is neutral, allowing for thermal expansion. There is no axial pre-load thrust on the engine or alternator bearings.
 8. Offer the alternator to the engine and engage coupling discs and housing spigots at the same time, pushing the alternator towards the engine until the coupling discs are against the flywheel face and the housing spigots are located.

NOTICE

Do not pull the alternator to the engine using bolts through the flexible discs.

9. Fit heavy gauge washers under the heads of housing and coupling bolts. Screw in the bolts evenly around the coupling assembly to maintain correct alignment.
10. Tighten the bolts to fix the coupling disc to the flywheel, in the sequence shown in [Figure 21 on page 38](#)
11. Check the torque of each bolt in a clockwise direction around the bolt circle to ensure all the bolts are tight. Refer to the engine manufacturer's manual for correct tightening torque.
12. Remove the rotor support bracket.
13. Replace all covers.

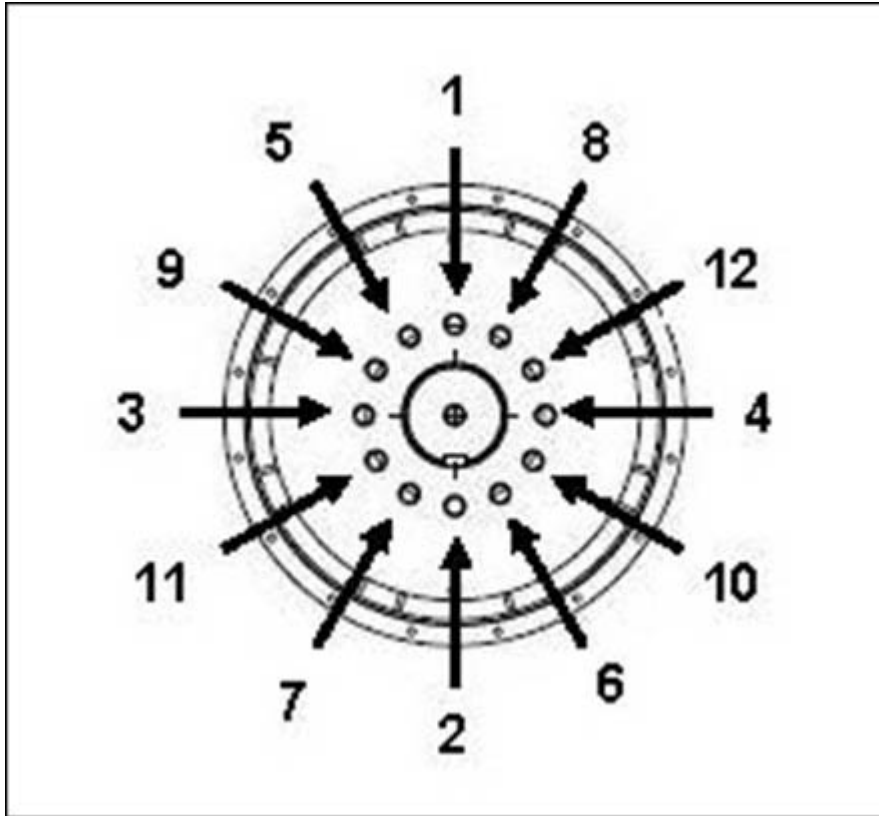

FIGURE 20. FIXING SEQUENCE TO HUB

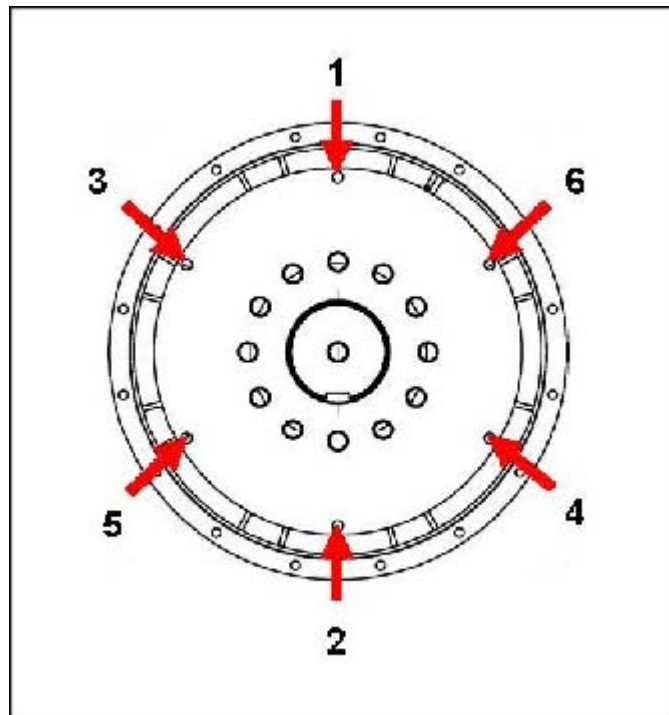

FIGURE 21. FIXING SEQUENCE TO FLYWHEEL

7.3 Two Bearing Alternators

A flexible coupling, designed to suit the specific engine/alternator combination, is recommended to minimize torsional vibration effects.

If a close coupling adaptor is used the alignment of machined faces must be checked by offering the alternator up to the engine. Shim the alternator feet if necessary.

7.4 Pre-Running Checks

Before starting the generator set, test the insulation resistance of windings and check that all connections are tight and in the correct location. Make sure the alternator air path is clear of obstructions. Replace all covers.

7.5 Direction of Rotation

As standard, alternator rotation is clockwise, as viewed from the drive end (unless counter-clockwise rotation is specified when ordering). The fan must be changed if the direction of rotation is changed, speak to STAMFORD® or AvK® customer services www.stamford-avk.com.

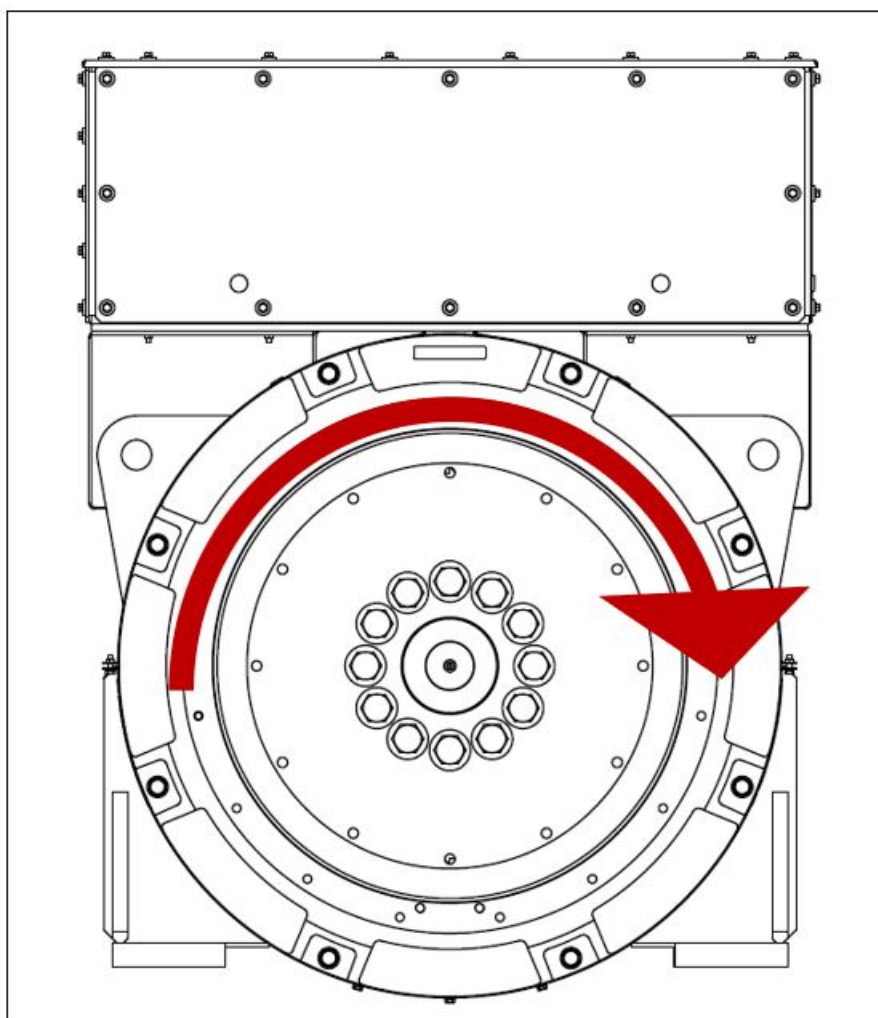

FIGURE 22. DIRECTION OF ROTATION

7.6 Phase Rotation

Main stator output is connected for a phase sequence of U V W when the alternator runs clockwise, as viewed from the drive end. If the phase rotation must be reversed, the customer must re-connect the output cables in the terminal box. STAMFORD | AvK™ customer services www.stamford-avk.com for a circuit diagram of 'reverse phase connections'.

7.7 Voltage and Frequency

Check that the voltage and frequency shown on the alternator rating plate meet the requirements of the generator set application. Refer to detailed instructions in the AVR manual for adjustments.

7.8 AVR Settings

The AVR is factory set for initial running tests. Check that the AVR settings are compatible with your required output. Refer to detailed instructions in the AVR manual for on- and off-load adjustments.

7.9 Electrical Connections

 **WARNING**

Incorrect Electrical Installation and System Protection

Incorrect electrical installation and / or system protection can cause serious injury or death by electric shock and burns. To prevent injury or death and before starting work, personnel:

- ***Have completed related, applicable and approved training.***
- ***Know the equipment, understand the task(s) and procedure(s).***
- ***Know related hazards / risks.***
- ***Know and obey site / location specific emergency procedures and applicable laws and regulations.***

The terminal box is designed to support the fitted busbars or terminals, transformers, load cables and auxiliary terminal box. Additional mass could cause excessive vibration and lead to failure of the terminal box enclosure and mounting. Speak to STAMFORD | AvK™ customer services www.stamford-avk.com before fixing any additional mass to the terminal box. Panels must be removed to be drilled or cut, to prevent swarf entering the terminal box or alternator.

Fault current curves and alternator reactance values are available on request from the factory so that the system designer can calculate the necessary fault protection and/or discrimination.

The installer must check that the alternator frame is bonded to the generator set bedplate, and must bond to site earth. If anti-vibration mounts are fitted between the alternator frame and its bedplate, a suitably-rated earth conductor must bridge across the anti-vibration mount.

Refer to wiring diagrams for electrical connection of the load cables. Electrical connections are made in the terminal box, constructed with removable panels to suit site-specific cable entry and glanding. Route single core cables through the insulated or non-magnetic gland plates supplied. Panels must be removed to be drilled or cut to prevent swarf entering the terminal box or alternator. After wiring, inspect the terminal box, remove all debris using a vacuum cleaner if necessary and check that no internal components are damaged or disturbed.

As standard, the alternator neutral is not bonded to the alternator frame. If required, neutral may be connected to the earth terminal in the terminal box, by a conductor of at least one half of the sectional area of a phase lead.

Load cables must be supported appropriately to avoid a tight radius at the point of entry into the terminal box, clamped at the terminal box gland, and allow at least ± 25 mm movement by the alternator set on its anti-vibration mountings, without causing excessive stress to the cables and alternator load terminals.

The palm (flattened part) of load cable lugs must be clamped in direct contact with the main stator load output terminals so that the whole palm area conducts the output current. Using a torque wrench on the uppermost nut and a spanner positioned on the nut below, apply equal reverse leverage to avoid damaging the insulation post. The tightening torque of M12 fasteners is 70 Nm (51.6 ft-lb) (main nut) and 45 Nm (33.2 ft-lb) (lock nut) on insulated terminals.

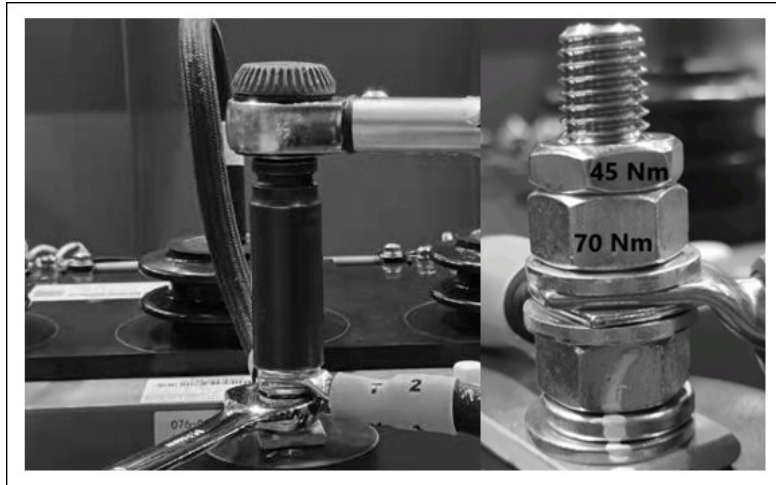

FIGURE 23. CORRECT CABLE CLAMPING (MULTIPLE CABLES)

7.10 Grid Connection: Voltage Surges and Micro-Interruptions

Consideration should be given to any transient voltages loads generated by connected loads and/or distribution system which could damage the alternator components.

According to the specifics of the application and installation the points below must be considered:

- Loads with characteristics that result in large load step changes.
- Load control by switchgear and power control by any method likely to generate transient voltage spikes.
- Distribution systems susceptible to external influences, such as lightning strikes.
- Applications involving parallel operation to a mains supply, where the risk of a mains disturbance in the form of a micro-interruption could occur.

If the alternator is at risk from voltage surges or micro-interruptions, it is recommended that the installation includes adequate protection of the generation system to meet regulations and installation requirements. It is recommended to seek guidance from specialist protection system designers and associated professional bodies.

7.11 Varying Load

Under certain conditions, load variations can reduce alternator life.

Identify any possible risk, especially the following:

- Large capacitive loads (for example Power Factor Correction equipment) can affect alternator stability and cause pole slip.
- Stepped grid voltage variation (for example Tap Changing).

If the alternator is at risk from varying load, include adequate protection into the generator set system by under-excitation protection.

7.12 Synchronization

⚠ WARNING

Exposure to Ejected Debris and Particles

Ejected debris and particles can cause serious injury or death by impact, severing or puncturing. Exposure to mechanically driven release of debris and particles exists in all directions (horizontally and vertically) in the areas surrounding the alternator air outlet(s), air inlets(s) and the open shaft end (also commonly known as the Drive End (DE)). To prevent injury or death:

- *Keep away from the air inlet(s) and air outlet(s) when the alternator is operating.*
- *Do not position operator controls near the air inlet(s) or air outlet(s).*
- *Do not cause overheating by running the alternator outside rating plate parameters.*
- *Do not overload the alternator.*
- *Do not operate an alternator displaying excessive vibration.*
- *Do not synchronize parallel alternators outside the specified parameters.*

7.12.1 Parallel or Synchronizing Alternators

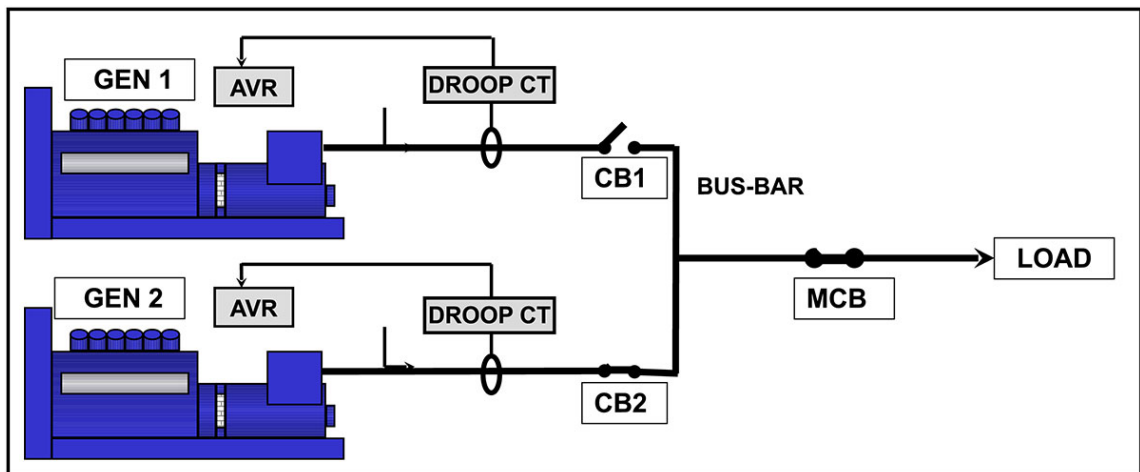

FIGURE 24. PARALLEL OR SYNCHRONIZING ALTERNATORS

The quadrature droop current transformer (Droop CT) gives a signal proportional to reactive current. The AVR adjusts excitation to reduce circulating current and allow each alternator to share reactive load. A factory-fitted droop CT is pre-set for 5% voltage drop at full-load zero power factor. Refer to the supplied AVR manual for droop adjustment.

- The synchronizing switch/breaker (CB1, CB2) must be of a type that will not cause “contact bounce” when it operates.
- The synchronizing switch/breaker must be adequately rated to withstand the continuous full load current of the alternator.
- The switch/breaker must be able to withstand the rigorous closing cycles during synchronizing and the currents produced if the alternator is paralleled out of synchronization.
- The closing time of the synchronizing switch/breaker must be under the control of the synchronizer settings.
- The switch/breaker must be capable of operation under fault conditions such as short circuits. Alternator data sheets are available.

-

NOTICE

The fault level may include a contribution from other alternators as well as from the grid/mains utility.

The method of synchronizing should be either automatic, or by check synchronizing. The use of manual synchronizing is not recommended. The settings on the synchronizing equipment should be such that the alternator will close smoothly. For the synchronizing equipment to achieve this, the phase sequence must match the parameters in the table below.

TABLE 7. SYNCHRONIZING EQUIPMENT PARAMETERS

Voltage Difference	+/- 0.5%
Frequency Difference	0.1 Hz/sec
Phase Angle	+/- 10°
C/B Closing Time	50 ms

The voltage difference when paralleling with the grid/mains utility is +/- 3%.

-

This page is intentionally blank.

8 Service and Maintenance

8.1 Recommended Service Schedule

Refer to: Safety Precautions in [Chapter 2 on page 3](#) before starting any service and maintenance activity.

Refer to: Parts Identification in [Chapter 9 on page 71](#) for an exploded view of components and fastener information.

The recommended service schedule shows the recommended service activities in table rows, grouped by alternator subsystem. Columns of the table show the types of service activity, whether the alternator must be running, and the service levels. Service frequency is given in running hours or time interval, whichever is sooner. A cross (X) in the cells where a row intersects the columns shows a service activity type and when it is required. An asterisk (*) shows a service activity done only when necessary.

All service levels in the recommended service schedule can be purchased directly from STAMFORD | AvK™ customer services www.stamford-avk.com.

1. Proper service and repair are vital to the reliable operation of your alternator and the safety of anyone coming into contact with the alternator.
2. These service activities are intended to maximize the life of the alternator but shall not vary, extend or change the terms of the manufacturer's standard warranty or your obligations in that warranty.
3. Each service interval is a guide only, and developed on the basis that the alternator was installed and is operated in accordance with the manufacturer's guidelines. If the alternator is located and/or operated in adverse or unusual environmental conditions, the service intervals may need to be more frequent. The alternator should be continually monitored between services to identify any potential failure modes, signs of misuse, or excessive wear and tear.

8.1.1 Alternator Service Schedule

TABLE 8. ALTERNATOR SERVICE SCHEDULE

System	SERVICE ACTIVITY X = required * = if necessary	Alternator running	TYPE				SERVICE LEVEL						
			Inspect	Test	Clean	Refill/Replace	Commission	Post Commission 250 hrs / 0.5 year	Level 1 1000 hrs / 1 year	Level 2 10,000 hrs / 2 years	Level 3 30,000 hrs / 5 years		
Alternator	Alternator rating		X				X						
	Bedplate arrangement		X				X						
	Coupling arrangement		X				X			*		X	
	Environmental conditions and cleanliness		X				X	X	X	X		X	
	Ambient temperature (inside & outside)			X			X	X	X	X		X	
	Complete machine - damage, loose parts & earth bonds		X				X	X	X	X		X	
	Guards, screens, warning and safety labels		X				X	X	X	X		X	
	Maintenance access		X				X						
	Electrical nominal operating conditions & excitation	X		X			X	X	X	X		X	
	Vibration	X		X			X	X	X	X		X	
Windings	Condition of windings		X				X	X	X	X		X	
	Insulation resistance of all windings (PI test for MV/HV)			X			X	*	*		X	X	
	Insulation resistance of rotor, exciter and PMG			X				X	X				
	Temperature sensors	X		X			X	X	X	X		X	
	Customer settings for temperature sensors		X				X						

System	SERVICE ACTIVITY X = required * = if necessary	Alternator running	TYPE				SERVICE LEVEL							
			Inspect	Test	Clean	Refill/Replace	Commission	Post Commission	250 hrs / 0.5 year	Level 1	1000 hrs / 1 year	Level 2	10,000 hrs / 2 years	Level 3
Bearings	Condition of bearings		X				X							X
	Grease exhaust & trap				X			every 3000 to 3500 hours / 6 months						
	Re-grease bearing(s) (A to H core length)	X				X		every 3000 to 3500 hours / 6 months						
	Replace re-greasable bearing(s)					X					*		X	
	Temperature sensors	X		X			X	X	X	X	X	X		
	Customer settings for temperature sensors		X				X							
Terminal Box	All alternator/customer connections and cabling		X				X	X	X	X	X	X		
Controls & Auxiliaries	Initial AVR & PFC set up	X		X			X							
	AVR & PFC settings	X		X				X	X	X	X	X		
	Customer connection of auxiliaries			X			X		X	X	X	X		
	Function of auxiliaries			X			X	X	X	X	X	X		
	Synchronization settings		X				X							
	Synchronization	X		X			X	X	X	X	X	X		
	Anti condensation heater					X					*	X		
Rectifier	Diodes and varistors		X				X	X	X	X	X			
	Diodes and varistors					X						X		
Cooling	Air inlet temperature	X		X			X	X	X	X	X	X		
	Air flow (rate & direction)	X	X				X							
	Condition of fan		X				X	X	X	X	X	X		
	Condition of air filter (where fitted)			X			X	X	X	X	X	X		
	Air filters (where fitted)				X	X			*	*	*	*		

8.2 Bearings

8.2.1 Introduction

NOTICE

Do not overfill a bearing with grease, the bearing can be damaged.
Do not mix lubricant types.
Change gloves to handle different lubricant
Assemble bearings in static and dust-free conditions, wearing lint free gloves.
To prevent damage or contamination, store removed parts and tools in static and dust-free conditions.
Do not reuse bearings. Bearings are damaged by the axial force needed to remove it from the rotor shaft.
Do not press fit bearing. Bearings are damaged if the insertion force is applied through the bearing balls.
Do not try to turn the rotor by levering against the cooling fan vanes. The fan will be damaged.

The alternator rotor is supported by a bearing at the non-drive end (NDE) and by either a bearing or a coupling to the prime mover at the drive end (DE).

- Lubricate each re-greasable bearing according to the recommended service schedule with the correct quantity and type of grease, also shown on a label fitted at the grease nipple.

8.2.2 Safety

DANGER

Rotating Mechanical Parts

Rotating mechanical parts can cause serious injury or death by crushing, severing or trapping. To prevent injury:

- ***Before operating the alternator: The rotating coupling between the alternator and prime mover must be covered by a guard or cover.***
- ***Before attempting service or maintenance tasks or removing covers from rotating parts: Shut down and isolate the generator set from all energy sources, isolate stored energy and use lock out/tag out safety procedures.***

WARNING

Hot Surfaces and Fire

Contact with hot surfaces can cause serious injury and death by burns. A risk of fire exists where hot surfaces are contacted by combustible items. To prevent injury, death or risk of fire:

- ***Avoid contact with hot surfaces.***
- ***Always wear the appropriate personal protection equipment, refer to: Safety Precaution Chapter.***
- ***Make sure combustible materials or flammable substances are not stored close to or contact the anti-condensation heater (if fitted).***
- ***Make sure combustible materials or flammable substances are not stored close to the alternator or prime mover, including the ventilation and exhaust system(s) where applicable.***

⚠ WARNING

Exposure to Ejected Debris and Particles

Ejected debris and particles can cause serious injury or death by impact, severing or puncturing. Exposure to mechanically driven release of debris and particles exists in all directions (horizontally and vertically) in the areas surrounding the alternator air outlet(s), air inlets(s) and the open shaft end (also commonly known as the Drive End (DE)). To prevent injury or death:

- *Keep away from the air inlet(s) and air outlet(s) when the alternator is operating.*
- *Do not position operator controls near the air inlet(s) or air outlet(s).*
- *Do not cause overheating by running the alternator outside rating plate parameters.*
- *Do not overload the alternator.*
- *Do not operate an alternator displaying excessive vibration.*
- *Do not synchronize parallel alternators outside the specified parameters.*

⚠ CAUTION

Hazardous Substances

Hazardous substances can cause minor or moderate injury. Prolonged or repetitive exposure to hazardous substances can cause serious medical conditions. To prevent injury:

- *Always read and obey the instructions provided by the product manufacturer.*
- *Use, handle and store substances as specified by the product manufacturer.*
- *Always wear appropriate personal protective equipment, refer to Safety Precautions Chapter.*

8.2.3 Re-Grease Bearings

8.2.3.1 Requirements

TABLE 9. RE-GREASING: EQUIPMENT REQUIREMENTS

Requirement	Description
Personal Protective Equipment (PPE)	<ul style="list-style-type: none">• Wear appropriate protective equipment as directed by site rules and risk assessment requirements.
Consumables	<ul style="list-style-type: none">• Lint-free cleaning cloths• Thin disposable gloves
Parts	<ul style="list-style-type: none">• CGT recommended grease
Tools	<ul style="list-style-type: none">• Grease gun (calibrated for volume or mass)

8.2.3.2 Re-grease Method

TABLE 10. REGREASING: GREASE QUANTITY

Bearing Type	Quantity of recommended grease	
	Volume (cm ³)	Mass (g)
Drive End (S9 Core length A, B, C, D)	126	121
Drive End (S9 Core length E, F)	180	173
Drive End (S9 Core length G, H)	94	90
Non-Drive End (S9 A, B, C, D, E, F)	157	151
Non-Drive End (S9 G, H)	182	175

1. For each bearing, identify grease nipple, re-greasing label and bearing type.
2. Make sure the new grease is not contaminated. It must be a uniform whitish-beige colour of stiff consistency throughout.
3. Clean the grease gun nozzle and grease nipple.
4. Clean the grease exhaust.
5. Where an air filter is fitted, with the alternator stopped, remove the NDE cover and air filter and clean the exhausted grease trap. Afterwards, replace the air filter and reinstall the NDE cover.
6. With the alternator running, fit the grease gun to the grease nipple and add the correct quantity of grease.
7. Run the alternator for at least 60 minutes, off-load.
8. Remove the grease trap, clean the grease exhaust and re-fit.
9. Inspect the colour and consistency of grease expelled from the exhaust and compare with new grease - whitish-beige of stiff consistency.
10. Replace the bearing if the expelled grease is severely discoloured or absent.

NOTICE

If the exhaust grease trap overflows, the stator and rotor windings would be contaminated. Make sure trap is emptied when re-greasing.

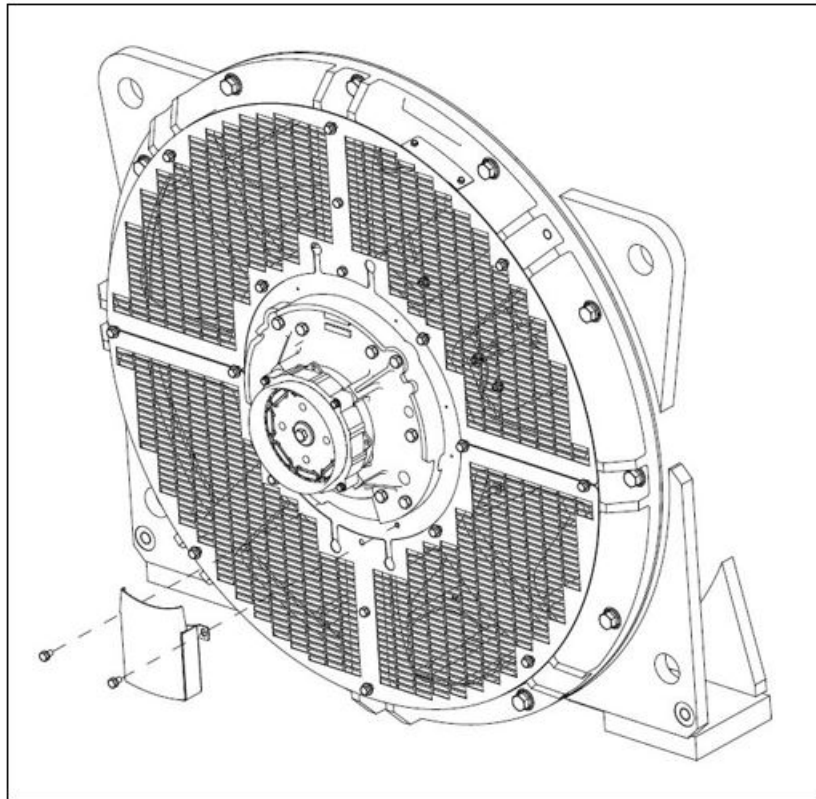

FIGURE 25. GREASE TRAP S9

8.3 Controls

8.3.1 Introduction

An operating alternator is a harsh environment for control components. Heat and vibration can cause electrical connections to loosen and cables to fail. Routine inspection and test can identify an issue before it becomes a failure that incurs unplanned downtime.

8.3.2 Safety

⚠ DANGER

Live Electrical Conductors

Live electrical conductors can cause serious injury or death by electric shock and burns. To prevent injury and before working on live conductors:

- ***Shut down and isolate the alternator from all energy sources.***
- ***Remove or isolate stored energy.***
- ***Test isolated parts for electrical isolation using a suitable voltage tester.***
- ***Use lock out/tag out safety procedures.***

⚠ WARNING

Hot Surfaces and Fire

Contact with hot surfaces can cause serious injury and death by burns. A risk of fire exists where hot surfaces are contacted by combustible items. To prevent injury, death or risk of fire:

- Avoid contact with hot surfaces.
- Always wear the appropriate personal protection equipment, refer to: Safety Precaution Chapter.
- Make sure combustible materials or flammable substances are not stored close to or contact the anti-condensation heater (if fitted).
- Make sure combustible materials or flammable substances are not stored close to the alternator or prime mover, including the ventilation and exhaust system(s) where applicable.

⚠ WARNING

Incorrect Electrical Installation and System Protection

Incorrect electrical installation and / or system protection can cause serious injury or death by electric shock and burns. To prevent injury or death and before starting work, personnel:

- Have completed related, applicable and approved training.
- Know the equipment, understand the task(s) and procedure(s).
- Know related hazards / risks.
- Know and obey site / location specific emergency procedures and applicable laws and regulations.

8.3.3 Connection Test Requirements

TABLE 11. CONNECTION TEST REQUIREMENTS

Requirements	Description
Personal Protective Equipment (PPE)	<ul style="list-style-type: none">• Wear appropriate protective equipment as directed by site rules and risk assessment requirements.
Consumables	<ul style="list-style-type: none">• None
Parts	<ul style="list-style-type: none">• None
Tools	<ul style="list-style-type: none">• Insulation test meter• Multimeter• Torque wrench

8.3.4 Inspect and Test

1. Remove the terminal box lid
2. Check the tightness of fasteners securing the load cables.
3. Check that cables are firmly clamped at the terminal box gland, and allow ± 25 mm movement by an alternator on anti-vibration mounts.
4. Check that all cables are anchored and unstressed within the terminal box.

5. Check all cables for signs of damage caused by vibration, including insulation wear and wire strand breaks.
6. Check that all AVR accessories and current transformers are correctly fitted, and cables pass centrally through current transformers.
7. If an anti-condensation heater is fitted:
 - a. Isolate the supply and measure electrical resistance of the heater element(s). Replace heater element if open circuit.
 - b. Connect together both ends of the heater leads.
 - c. Apply the test voltage between the winding and earth.
 - d. Measure the insulation resistance after 1 minute (IR 1min).
 - e. Discharge the voltage.
 - f. If the measured insulation resistance is less than the minimum acceptable value, replace the heater element(s), refer to: [Table 12 on page 53](#) for values.
8. Test the supply voltage to the anti-condensation heaters (if fitted). 100 VAC to 277 VAC should be present across each heater element when the alternator is stopped. Refer to the wiring diagram for heater connections.
9. Check that AVR and AVR accessories within the terminal box are clean, securely fitted on anti-vibration mounts, and the cable connectors are firmly attached to the terminals. AVR and AVR accessories do not need further routine servicing.
10. For parallel operation, check that alternator frequency signal cables to the synchronization equipment are securely connected.
11. Refit the terminal box lid.

TABLE 12. TEST VOLTAGE AND MINIMUM ACCEPTABLE INSULATION RESISTANCE FOR NEW AND IN-SERVICE ANTI-CONDENSATION HEATERS

	Test Voltage (V)	Minimum Insulation Resistance at 1 minute (MΩ)	
		New	In-service
Anti-condensation heater	500	10	1

8.4 Cooling System

8.4.1 Introduction

The alternators are designed to meet standards supporting EU Directives and UK Statutory Instruments, and are rated for the effect of operating temperature on winding insulation.

BS EN 60085 (≡ IEC 60085) Electrical insulation – Thermal Evaluation and Designation classifies insulation capability by the maximum operating temperature for a reasonable design and service life. When considering thermal design life, thermal conditioning of insulation system components and their combination are predominantly influenced by the level of thermal stress applied to the system. Additional, single or a combination of factors such as mechanical, electrical and environmental stress, may cause degradation over time, but these are considered secondary when considering thermal degradation of an insulation system.

If the operating environment differs from the values shown on the rating plate, rated output must be reduced by

- 3% for class H utilization for every 5 °C that the temperature of the ambient air entering the cooling fan exceeds 40 °C, up to a maximum of 60 °C

- 3.5% for class F utilization for every 5 °C that the temperature of the ambient air entering the cooling fan exceeds 40 °C, up to a maximum of 60 °C
- 4.5% for class B utilization for every 5 °C that the temperature of the ambient air entering the cooling fan exceeds 40 °C, up to a maximum of 60 °C
- 3% for every 500 m increase in altitude above 1000 m, up to 4000 m*, due to the reduced thermal capacity of lower density air, and
- 5% if air filters are fitted due to restricted air flow.

NOTICE

The values above are cumulative dependent on environmental conditions.

Efficient cooling depends on maintaining the condition of the cooling fan, air filters and gaskets.

* The following changes to the insulation system of medium and high voltage alternators, must be applied to minimize the adverse effects of operating at higher altitudes, to ensure normal operational life expectancy. The changes are calculated according to the specific alternator design and Pashen's Curve.

- Up to 1500 m elevation: No change to insulation system required
- 1500 - 3000 m elevation: Requires a change to the insulation system design to meet altitude operational requirements. Maximum system voltage (Un) designs up to 11 kV. This design upgrade is factory manufactured only.
- 3000 - 4000 m elevation: Requires a change to the insulation system design to meet altitude operational requirements. Maximum system voltage (Un) designs up to 6.6 kV. This design upgrade is factory manufactured only.

NOTICE

For alternators with nominal design voltage above 1.1 kV, thermal derate due to the change in insulation system design to meet higher altitude operational conditions above 1000 MASL cannot be assumed based on standard derate factors. Advice must be obtained from Cummins Generator Technologies, as special considerations are required to allow for increased insulation systems thermal transfer capabilities.

8.4.2 Safety

⚠ DANGER

Rotating Mechanical Parts

Rotating mechanical parts can cause serious injury or death by crushing, severing or trapping. To prevent injury:

- ***Before operating the alternator: The rotating coupling between the alternator and prime mover must be covered by a guard or cover.***
- ***Before attempting service or maintenance tasks or removing covers from rotating parts: Shut down and isolate the generator set from all energy sources, isolate stored energy and use lock out/tag out safety procedures.***

⚠ WARNING

Hot Surfaces and Fire

Contact with hot surfaces can cause serious injury and death by burns. A risk of fire exists where hot surfaces are contacted by combustible items. To prevent injury, death or risk of fire:

- Avoid contact with hot surfaces.
- Always wear the appropriate personal protection equipment, refer to: Safety Precaution Chapter.
- Make sure combustible materials or flammable substances are not stored close to or contact the anti-condensation heater (if fitted).
- Make sure combustible materials or flammable substances are not stored close to the alternator or prime mover, including the ventilation and exhaust system(s) where applicable.

⚠ CAUTION

Dust & Airborne Particles/Fumes

Dust and other airborne particles and fumes can cause minor or moderate injury by irritating the lungs and eyes. Prolonged or repetitive exposure can cause serious medical conditions. To prevent injury:

- Use mechanical vacuum extraction to remove dust and airborne particles or fumes.
- Ventilate the area fully.
- Always wear the appropriate personal protective equipment. Refer to Safety Precautions Chapter.

NOTICE

Do not attempt to rotate the alternator rotor by levering against the vanes of the cooling fan. The fan is not designed to withstand such forces and will be damaged.

NOTICE

Filters are designed to remove dust, not moisture. Wet filter elements can cause reduced air flow and overheating. Do not allow filter elements to get wet.

8.4.3 Cooling System Test Requirements

TABLE 13. COOLING SYSTEM TEST REQUIREMENTS

Requirements	Description
Personal Protective Equipment (PPE)	<ul style="list-style-type: none">• Wear appropriate protective equipment as directed by site rules and risk assessment requirements.
Consumables	<ul style="list-style-type: none">• Lint-free cleaning cloths• Thin disposable gloves
Parts	<ul style="list-style-type: none">• Air filters (if fitted)• Air filter sealing gaskets (if fitted)
Tools	<ul style="list-style-type: none">• None

8.4.4 Inspect and Clean

1. Inspect the fan for damaged vanes and cracks.
2. Remove air filters (at the fan and terminal box, if fitted) from their frames.
3. Wash and dry the air filters and gaskets to remove contaminant particles.
4. Inspect the filters and gaskets for damage and replace, as necessary.
5. Install the filters and gaskets.
6. Reinstall the generator set for running.
7. Make sure the air inlets and outlets are not blocked.

8.5 Coupling

8.5.1 Introduction

Efficient operation and long component life rely on minimizing mechanical stresses on the alternator. When coupled in a generator set, misalignment and vibration interactions with the prime mover engine can cause mechanical stress.

The rotational axes of alternator rotor and engine output shaft must be coaxial (radial and angular alignment).

Torsional vibration can cause damage to internal combustion engine shaft-driven systems, if not controlled. The generator set manufacturer is responsible for assessing the effect of torsional vibration on the alternator. Rotor dimensions, inertia, and coupling details are available on request.

8.5.2 Safety

NOTICE

Do not attempt to rotate the alternator rotor by levering against the vanes of the cooling fan. The fan is not designed to withstand such forces and will be damaged.

⚠ WARNING

Coupling an Alternator

Moving mechanical parts during coupling can cause serious injury by crushing, severing or trapping. When coupling the alternator to a prime-mover or when installing large components, to prevent injury:

- *Personnel must keep limbs and body parts away from coupling surfaces during coupling and/or installing operations.*

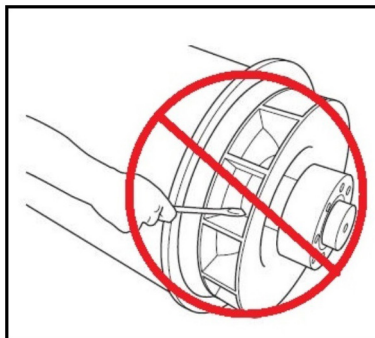

FIGURE 26. DO NOT ROTATE THE ALTERNATOR ROTOR WITH A LEVER

8.5.3 Coupling Test Requirements

TABLE 14. COUPLING TEST REQUIREMENTS

Requirements	Description
Personal Protective Equipment (PPE)	<ul style="list-style-type: none">Wear appropriate protective equipment as directed by site rules and risk assessment requirements.
Consumables	<ul style="list-style-type: none">None
Parts	<ul style="list-style-type: none">None
Tools	<ul style="list-style-type: none">Dial gaugeTorque wrench

8.5.4 Inspect Mounting Points

1. Check the generator set bedplate and mounting pads are in good condition, not cracked.
2. Check that rubber in anti-vibration mounts has not perished.
3. Check vibration monitoring historical records for a trend of increasing vibration.

8.5.4.1 One Bearing Coupling

1. Remove the DE adaptor screen and cover to access the coupling.
2. Check that the coupling discs are not damaged, cracked or distorted, and the coupling disc holes are not elongated. If any are damaged, replace the complete set of discs.
3. Check tightness of bolts fixing the coupling discs to the engine flywheel. Tighten in the sequence shown for alternator coupling in the Installation chapter, to the torque recommended by the engine manufacturer.
4. Replace the DE adaptor screen and drip proof cover.

8.6 Rectifier System

8.6.1 Introduction

The rectifier converts alternating current (AC) induced in the exciter rotor windings into direct current (DC) to magnetize the main rotor poles. The rectifier comprises two semicircular annular positive and negative plates, each with three diodes. In addition to connecting to the main rotor, the DC output of the rectifier also connects to a matched pair of varistors (one at each end of the plates) and two pairs of resistors, if fitted (mounted into holes in the exciter rotor). These additional components protect the rectifier from voltage spikes and surge voltages that may be present on the rotor under various loading conditions of the alternator.

Diodes provide a low resistance to current in one direction only: Positive current will flow from anode to cathode, or another way of viewing it is that negative current will flow from cathode to anode.

The exciter rotor windings are connected to 3 diode anodes to form the positive plate and to 3 diode cathodes to form the negative plate to give full wave rectification from AC to DC. The rectifier is mounted on, and rotates with, the exciter rotor at the non-drive end (NDE).

8.6.2 Safety

⚠ DANGER

Live Electrical Conductors
Live electrical conductors can cause serious injury or death by electric shock and burns. To prevent injury and before working on live conductors:

- **Shut down and isolate the alternator from all energy sources.**
- **Remove or isolate stored energy.**
- **Test isolated parts for electrical isolation using a suitable voltage tester.**
- **Use lock out/tag out safety procedures.**

⚠ DANGER

Rotating Mechanical Parts
Rotating mechanical parts can cause serious injury or death by crushing, severing or trapping. To prevent injury:

- **Before operating the alternator: The rotating coupling between the alternator and prime mover must be covered by a guard or cover.**
- **Before attempting service or maintenance tasks or removing covers from rotating parts: Shut down and isolate the generator set from all energy sources, isolate stored energy and use lock out/tag out safety procedures.**

⚠ WARNING

Incorrect Electrical Installation and System Protection
Incorrect electrical installation and / or system protection can cause serious injury or death by electric shock and burns. To prevent injury or death and before starting work, personnel:

- **Have completed related, applicable and approved training.**
- **Know the equipment, understand the task(s) and procedure(s).**
- **Know related hazards / risks.**
- **Know and obey site / location specific emergency procedures and applicable laws and regulations.**

8.6.3 Requirements

TABLE 15. RECTIFIER SYSTEM: TEST AND REPLACE COMPONENT REQUIREMENTS

Personal Protective Equipment (PPE)	<ul style="list-style-type: none"> • Wear appropriate protective equipment as directed by site rules and risk assessment requirements.
Consumables	<ul style="list-style-type: none"> • Dow Corning Silicone heat sink compound type 340 or similar. • Duralco 4461N Amber Electrically Resistant Epoxy [Part: 030-02668]. If Resistors are fitted. • Vidaflex 942 Acrylic 3mm sleeving [Part: 030-01548]. If Resistors are fitted. • Vidaflex 942 Acrylic 5mm sleeving [Part: 030-01550]. If Resistors are fitted. • Sumitube B2 Polyolefin heat shrink 9.5mm tubing [Part: 030-04179]. If Resistors are fitted.

Parts	<ul style="list-style-type: none"> • Kit of three Anode lead Diodes and three Cathode lead Diodes (all from the same manufacturer). • Kit of two metal-oxide Varistors (same type, same manufacturer, same voltage grading: A, B, C, D, E, F). • Kit of four Snubber Resistors (same type, same manufacturer). If fitted.
Tools	<ul style="list-style-type: none"> • Multimeter. • Insulation tester. • Torque wrench. • Resistor removal tool. If Resistors are fitted. • Hammer. If Resistors are fitted. • Round file. If Resistors are fitted.

8.6.4 Test and Replace Resistors - If Fitted

1. Inspect the visible ends of all four resistors.
2. Resistor is faulty if there are any signs of discoloration or overheating.
3. Break the electrical circuit by removing fasteners from one resistor of each pair. Store fasteners and washers.
4. Measure the total resistance of both resistor pairs, using the ohms range of a digital multimeter.
5. Resistors are faulty if the total resistance of a resistor pair is outside the range $160 \Omega \pm 10 \%$.
6. If resistors are faulty, replace all four resistors:
 - a. Remove the fasteners from the existing resistors.
 - b. Label and disconnect the six exciter rotor winding leads at the insulated terminal posts.
 - c. Label and disconnect the two main rotor winding leads at the terminals on the rectifier plate.
 - d. Disconnect a lead from both varistors to allow the rectifier plates to be removed separately.
 - e. Note the rotational position of the rectifier plates. Use a 5 mm Allen key to remove four M6 x 120 fasteners and both plates (complete with diodes) from the exciter rotor.
 - f. Cut the leads and connecting the bases of both resistor pairs.
 - g. Remove each resistor:
 - i. Resistors may disintegrate during removal. Position covers and vacuum extraction to collect any ceramic fragments.
 - ii. At the NDE, align the cylindrical removal tool squarely over the threaded terminal and onto the ceramic body of the resistor.
 - iii. Strike the free end of the tool sharply with a hammer to break the glue seal and then drive the resistor out of the hole towards the drive end.
 - h. Use a round file to remove resin from the rotor core holes. Clean with a lint-free cloth.
 - i. Loose fit a replacement resistor into each cleaned hole to check that all resin has been removed.
 - j. Apply 2 gm of epoxy and insert a replacement resistor into a rotor core hole, threaded post towards the rectifier plate position. Rotate the resistor to coat its surface evenly. Position the resistor so its base protrudes 3 mm from the core.
 - k. Repeat with the remaining three replacement resistors.
 - l. Leave the epoxy to cure.

- m. Fit a nut and a spring and flat washer on the M6 threaded post of each resistor.
- n. Refit the complete rectifier assembly onto the exciter rotor.
- o. Apply thread lock and fit a flat washer and stover nut on the M6 threaded post of each resistor. Ensure good electrical contact with the rectifier plate.
- p. Refer to the images and the steps below to finish and secure the resistor leads.

TABLE 16. RESISTOR LEAD CONNECTIONS

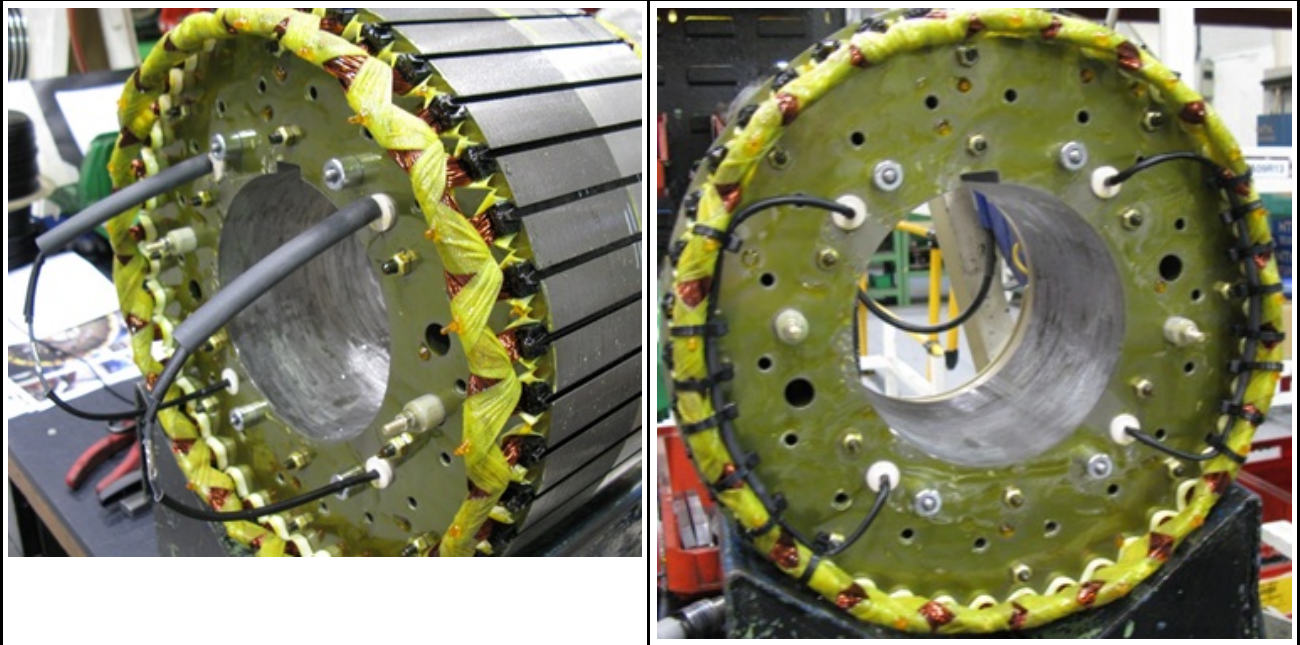

- q. Sleeve each resistor lead with 3 x 130 mm Vidaflex 942.
 - r. Sleeve two of the resistor leads (which are electrically connected through the rectifier plate) with 5 x 70 mm Vidaflex 942 and 9.5 x 100 mm heat shrink tubing (030-04179).
 - s. Connect by a crimped ferrule (003-09103) with the remaining resistor leads (electrically connected on the other rectifier plate) as shown.
 - t. Slide the 5 x 70 mm Vidaflex 942 and 9.5 x 100 mm heat shrink tubing over the ferrule and shrink the tube by heating.
 - u. Secure both lead assemblies to the inside of the exciter rotor windings with seven heat-stabilized cable ties (052-45017). Position the cable tie heads to the inside.
7. Replace both varistors with a matching pair (same type, same manufacturer and same voltage grading: A, B, C, D, E, F) (see below).
 8. Replace all diodes (see below).
 9. Reconnect and check that all leads are secure, washers fitted and fasteners tight.

8.6.5 Test and Replace Varistors

1. Inspect both varistors.
2. Record varistor as faulty if there are signs of overheating (discoloration, blisters, melting) or disintegration. Check for loose connectors vs. varistor body.
3. Disconnect the varistor leads.
4. A serviceable varistor will read open circuit in both directions using a multimeter (set in the Ohms (Ω) range). A faulty varistor can read short circuit in both directions and/or it may be physically damaged.

-
5. If either varistor is faulty, replace both varistors with a matched pair (same type, same manufacturer and same voltage grading: A, B, C, D, E, F) and replace all diodes.
 6. Reconnect and check that all leads are secure, washers fitted and fasteners tight.

8.6.6 Test and Replace Diodes

NOTICE

Do not tighten a diode above the stated torque. The diode will be damaged.

1. Disconnect the lead of one diode where it joins the windings at the insulated terminal post. Store fastener and washers.
2. Measure the voltage drop across the diode in the forward direction, using the diode test function of a multimeter.
3. Measure the resistance across the diode in the reverse direction, using the 1000 VDC test voltage of an insulation tester.
4. Diode is faulty if the voltage drop in the forward direction is outside the range 0.3–0.9 VDC, or the resistance is below 20 M Ω in the reverse direction.
5. Repeat the tests for the five remaining diodes.
6. If any diode is faulty, replace the full set of six diodes (same type, same manufacturer):
 - a. Remove diode(s).
 - b. Apply a small amount of heat sink compound **only** to the base of the replacement diode(s), not the threads.
 - c. Check polarity of diode(s).
 - d. Screw each replacement diode into a threaded hole in the rectifier plate.
 - e. Apply 2.6–3.1 Nm (23–27.4 in-lb) torque to give good mechanical, electrical and thermal contact.
 - f. Replace both varistors with a matched pair (same type, same manufacturer and same voltage grading: A, B, C, D, E, F)
7. Reconnect and check that all leads are secure, washers fitted and fasteners tight.

8.7 Temperature Sensors

8.7.1 Introduction

The alternators are designed to meet standards supporting EU Safety Directives, and recommended operating temperatures. Temperature sensors (where fitted) detect abnormal overheating of the main stator windings and bearing(s). Sensors are of Resistance Temperature Detector (RTD) type, with three wires terminated at a terminal block in the auxiliary terminal box. The resistance of Platinum (PT100) RTD sensors increases linearly with temperature.

TABLE 17. RESISTANCE (Ω) OF PT100 SENSOR BETWEEN 40 TO 180 °C

Temperature (°C)		+1 °C	+ 2 °C	+3 °C	+ 4 °C	+ 5 °C	+ 6 °C	+ 7 °C	+ 8 °C	+ 9 °C
40.00	115.54	115.93	116.31	116.70	117.08	117.47	117.86	118.24	118.63	119.01
50.00	119.40	119.78	120.17	120.55	120.94	121.32	121.71	122.09	122.47	122.86
60.00	123.24	123.63	124.01	124.39	124.78	125.16	125.54	125.93	126.31	126.69
70.00	127.08	127.46	127.84	128.22	128.61	128.99	129.37	129.75	130.13	130.52
80.00	130.90	131.28	131.66	132.04	132.42	132.80	133.18	133.57	133.95	134.33
90.00	134.71	135.09	135.47	135.85	136.23	136.61	136.99	137.37	137.75	138.13
100.00	138.51	138.88	139.26	139.64	140.02	140.40	140.78	141.16	141.54	141.91
110.00	142.29	142.67	143.05	143.43	143.80	144.18	144.56	144.94	145.31	145.69
120.00	146.07	146.44	146.82	147.20	147.57	147.95	148.33	148.70	149.08	149.46
130.00	149.83	150.21	150.58	150.96	151.33	151.71	152.08	152.46	152.83	153.21
140.00	153.58	153.96	154.33	154.71	155.08	155.46	155.83	156.20	156.58	156.95
150.00	157.33	157.70	158.07	158.45	158.82	159.19	159.56	159.94	160.31	160.68
160.00	161.05	161.43	161.80	162.17	162.54	162.91	163.29	163.66	164.03	164.40
170.00	164.77	165.14	165.51	165.89	166.26	166.63	167.00	167.37	167.74	168.11
180.00	168.48	-	-	-	-	-	-	-	-	-

Customer-supplied external equipment may be connected to monitor the sensors and generate signals to raise an alarm and to shut down the generator set.

BS EN 60085 (≡ IEC 60085) Electrical insulation – Thermal Evaluation and Designation classifies insulation of windings by the maximum operating temperature for a reasonable service life. To avoid damage to windings, signals should be set, appropriate to the insulation class shown on the alternator rating plate.

TABLE 18. ALARM AND SHUTDOWN TEMPERATURE SETTINGS FOR WINDINGS

Windings insulation	Max. Continuous temperature (°C)	Alarm temperature (°C)	Shutdown temperature (°C)
Class B	130	120	140
Class F	155	145	165
Class H	180	170	190

To detect overheating of bearings, control signals should be set according to the following table.

TABLE 19. ALARM AND SHUTDOWN TEMPERATURE SETTINGS FOR BEARINGS

Bearings	Alarm temperature (°C)	Shutdown temperature (°C)
Drive end bearing	45 + maximum ambient	50 + maximum ambient
Non-drive end bearing	40 + maximum ambient	45 + maximum ambient

8.7.2 Safety

DANGER

Live Electrical Conductors

Live electrical conductors can cause serious injury or death by electric shock and burns. To prevent injury and before working on live conductors:

- *Shut down and isolate the alternator from all energy sources.*
- *Remove or isolate stored energy.*
- *Test isolated parts for electrical isolation using a suitable voltage tester.*
- *Use lock out/tag out safety procedures.*

WARNING

Hot Surfaces and Fire

Contact with hot surfaces can cause serious injury and death by burns. A risk of fire exists where hot surfaces are contacted by combustible items. To prevent injury, death or risk of fire:

- *Avoid contact with hot surfaces.*
- *Always wear the appropriate personal protection equipment, refer to: Safety Precaution Chapter.*
- *Make sure combustible materials or flammable substances are not stored close to or contact the anti-condensation heater (if fitted).*
- *Make sure combustible materials or flammable substances are not stored close to the alternator or prime mover, including the ventilation and exhaust system(s) where applicable.*

8.7.3 Test RTD Temperature Sensors

1. Remove the auxiliary terminal box lid.
2. Identify the sensor leads at the terminal block and where each sensor is fitted.
3. Measure the resistance between the white and each red wire of one sensor.
4. Calculate the sensor temperature from the measured resistance.
5. Compare calculated temperature with temperature indicated by external monitoring equipment (if available).
6. Compare alarm and shutdown signal settings (if available) with recommended settings.
7. Repeat steps 3 to 7 for each sensor.
8. Refit the auxiliary terminal box lid.
9. Replace any faulty sensors.
10. Note: Main stator RTD are not replaceable. Bearing RTD are replaceable.

8.8 Windings

8.8.1 Introduction

NOTICE

Disconnect all control wiring and customer load leads from alternator winding connections before conducting these tests.

NOTICE

The Automatic Voltage Regulator (AVR) contains electronic components which would be damaged by high voltage applied during insulation resistance tests. The AVR must be disconnected before doing any insulation resistance test. Temperature sensors must be grounded to earth before doing any insulation resistance test.

Damp or dirty windings have a lower electrical resistance and could be damaged by insulation resistance tests at high voltage. If in doubt, test the resistance at low voltage (500 V) first.

Alternator performance depends on good electrical insulation of the windings. Electrical, mechanical and thermal stresses, and chemical and environmental contamination, cause the insulation to degrade. Various diagnostic tests indicate the condition of insulation by charging or discharging a test voltage on isolated windings, measuring current flow, and calculating the electrical resistance by Ohm's law.

When a DC test voltage is first applied, three currents can flow:

- **Capacitive Current:** To charge the winding to the test voltage (decays to zero in seconds),
- **Polarizing Current:** To align the insulation molecules to the applied electric field (decays to near-zero in ten minutes), and
- **Leakage Current:** Discharge to earth where the insulation resistance is lowered by moisture and contamination (increases to a constant in seconds).

For an insulation resistance test, a single measurement is made one minute after a DC test voltage is applied, when capacitive current has ended. For the polarization index test, a second measurement is made after ten minutes. An acceptable result is where the second insulation resistance measurement is at least double the first, because the polarization current has decayed. In poor insulation, where leakage current dominates, the two values are similar. A dedicated Insulation Tester takes accurate, reliable measurements and may automate some tests.

8.8.2 Safety

DANGER

Live Electrical Conductors

Live electrical conductors can cause serious injury or death by electric shock and burns. To prevent injury and before working on live conductors:

- ***Shut down and isolate the alternator from all energy sources.***
- ***Remove or isolate stored energy.***
- ***Test isolated parts for electrical isolation using a suitable voltage tester.***
- ***Use lock out/tag out safety procedures.***

DANGER

Testing Live Electrical Conductors

Live electrical conductors can cause serious injury or death by electric shock and burns. To prevent injury and before testing on or near live electrical conductors:

- ***Take applicable precautions to prevent contact with live conductors, refer to: Safety Precautions Chapter.***
- ***Test on or near live conductors, only if absolutely necessary.***
- ***Only trained personnel may test on or near live electrical conductors.***
- ***Do not test on or near live electrical conductors alone: Another competent person must be present, trained to isolate energy sources and take action in an emergency.***

⚠ WARNING

Condensed Water

Operating an alternator with condensed water in the windings can cause serious injury by electric shock, burns or exposure to flying debris and particles. To prevent injury and before operating the alternator:

- **Use anti-condensation heaters (if fitted) to prevent condensation accumulating.**
- **Check for condensed water.**
- **If condensed water is present, drain/remove the water, dry and inspect the alternator, refer to: Maintenance and Servicing Chapter.**

⚠ WARNING

Exposure to Particles and Fumes from an Alternator.

Particles and fumes can be released in all directions (horizontally and vertically) from where alternator ventilation is installed. To avoid or injury:

- **Avoid the areas around ventilation openings, air intake(s) and air outlet(s) when the alternator is operating.**
- **Use the correct personal protective equipment when working around an alternator.**

⚠ WARNING

Live Electrical Conductors

Live electrical conductors at the winding terminals can cause serious injury or death by electric shock or burns. After an insulation resistance test, to prevent injury or death:

- **Discharge the windings immediately after the test has concluded by shorting to a suitable earth. The windings must discharge for the greater of:**
 1. **A length of time equal to the duration of the test.**
 - or
 2. **5 minutes.**

⚠ WARNING

Incorrect Electrical Installation and System Protection

Incorrect electrical installation and / or system protection can cause serious injury or death by electric shock and burns. To prevent injury or death and before starting work, personnel:

- **Have completed related, applicable and approved training.**
- **Know the equipment, understand the task(s) and procedure(s).**
- **Know related hazards / risks.**
- **Know and obey site / location specific emergency procedures and applicable laws and regulations.**

8.8.3 Requirements

TABLE 20. WINDING TEST REQUIREMENTS

Requirement	Description
Personal Protective Equipment (PPE)	<ul style="list-style-type: none"> Wear appropriate protective equipment as directed by site rules and risk assessment requirements.
Consumables	<ul style="list-style-type: none"> None
Parts	<ul style="list-style-type: none"> None
Tools	<ul style="list-style-type: none"> Insulation test meter Multimeter Milliohm meter or micro ohmmeter Clamp ammeter Infrared thermometer Earth rod

8.8.4 Test the Electrical Resistance of Windings

1. Stop the alternator.
2. Verify the electrical resistance of the exciter field (stator) winding:
 - a. Disconnect the exciter field leads F1 and F2 from the AVR.
 - b. Measure and record the electrical resistance between F1 and F2 leads with a multimeter.
 - c. Reconnect the exciter field leads F1 and F2.
 - d. Make sure the fasteners are secure.
3. Verify the electrical resistance of the exciter armature (rotor) winding:
 - a. Mark the leads attached to diodes on one of the two rectifier plates.
 - b. Disconnect all exciter rotor leads from all diodes at the rectifier.
 - c. Measure and record the electrical resistance between pairs of marked leads (between phase windings). A specialist micro ohmmeter must be used.
 - d. Reconnect all exciter rotor leads to the diodes.
 - e. Make sure the fasteners are secure.
4. Verify the electrical resistance of the main field (rotor) winding:
 - a. Disconnect the two main rotor DC leads from the rectifier plates.
 - b. Measure and record the electrical resistance between the main rotor leads. A specialist micro ohmmeter must be used.
 - c. Reconnect the two main rotor DC leads to the rectifier plates.
 - d. Make sure the fasteners are secure.
5. Verify the electrical resistance of the main armature (stator) winding:
 - a. Disconnect the leads of the main stator from the output terminals.
 - b. Measure and record the electrical resistance between U1 and U2 leads and between U5 and U6 (if present). A specialist micro ohmmeter must be used.

- c. Measure and record the electrical resistance between V1 and V2 leads and between V5 and V6 (if present). A specialist micro ohmmeter must be used.
 - d. Measure and record the electrical resistance between W1 and W2 leads and between W5 and W6 (if present). A specialist micro ohmmeter must be used.
 - e. Reconnect the leads to the output terminals, as before.
 - f. Make sure the fasteners are secure.
6. Verify the electrical resistance of the PMG armature (stator) winding:
 - a. Disconnect the three PMG output leads P2, P3 and P4 from the AVR.
 - b. Measure and record the electrical resistance between pairs of the PMG output leads, with a multimeter.
 - c. Reconnect the three PMG output leads P2, P3 and P4 to the AVR.
 - d. Make sure the fasteners are secure.
 7. Refer to the winding resistance table in: [Chapter 10 on page 77](#) to verify the measured resistances of all windings agree with the reference values.

8.8.5 Test the Insulation Resistance of Windings

NOTICE	
The alternator must not be put into service until the minimum insulation resistance is achieved.	

TABLE 21. TEST VOLTAGE AND MINIMUM ACCEPTABLE INSULATION RESISTANCE FOR NEW AND IN-SERVICE ALTERNATORS

	Test Voltage (V)	Minimum Insulation Resistance at 1 minute (IR _{1min}) (MΩ)		Minimum Polarisation Index (PI = (IR _{10min}) / (IR _{1min}))
		New	In-service	
Medium voltage (MV) stator, 1 to 4.16 kV (each phase)	2500	100	50	2
High Voltage (HV) stator, 4.16 to 13.8 kV (each phase)	5000	300	150	2
PMG stator	500	5	3	N/A
Exciter stator	500	10	5	N/A
Exciter rotor, rectifier & main rotor combined	1000	200	100	N/A

1. Inspect the windings for mechanical damage or discoloration from overheating. Clean the insulation if there is hygroscopic dust and dirt contamination.
2. For Medium Voltage (MV) and High Voltage (HV) main stators:
 - a. Separate the three neutral leads.
 - b. Connect together both ends of each phase winding (if possible).
 - c. Ground two phases to earth.
 - d. Apply the test voltage from the table between the non-grounded phase and earth.
 - e. Measure the insulation resistance after 1 minute (IR_{1min}).
 - f. Measure the insulation resistance after 10 minutes (IR_{10min}).

-
- g. Discharge the test voltage with an earth rod for five minutes.
 - h. Calculate the polarization index ($PI = (IR_{10min}) / (IR_{1min})$)
 - i. Test the other two phases in turn.
 - j. If the equivalent insulation resistance or polarization index is less than the minimum acceptable values, dry the insulation, then repeat the method.
 - k. Remove the connections made for testing and reconnect the neutral leads. Refer to the Electrical Connections chapter for the correct torque settings.
3. For PMG and exciter stators, and combined exciter and main rotors:
 - a. Connect together both ends of the winding (if possible).
 - b. Apply the test voltage from the table between the winding and earth.
 - c. Measure the insulation resistance after 1 minute (IR_{1min}).
 - d. Discharge the test voltage with an earth rod for five minutes.
 - e. If the measured insulation resistance is less than the minimum acceptable value, dry the insulation, then repeat the method.
 - f. Repeat the method for each winding.
 - g. Remove the connections made for testing.

8.8.6 Dry the Insulation

Use the methods below to dry the insulation of the main stator windings. To prevent damage as water vapor is expelled from the insulation, make sure the winding temperature does not increase faster than 5 °C per hour or exceed 90 °C.

Plot the insulation resistance graph to show when drying is complete.

8.8.6.1 Dry with Ambient Air

In many cases, the alternator can be dried sufficiently using its own cooling system. Disconnect the cables from the X+ (F1) and XX- (F2) terminals of the AVR so there is no excitation voltage supply to the exciter stator. Run the generator set in this de-excited state. Air must flow freely through the alternator to remove the moisture. Operate the anti-condensation heater (if fitted) to assist the drying effect of the air flow.

After drying is complete, re-connect the cables between the exciter stator and AVR. If the generator set is not put into service immediately, turn on the anti-condensation heater (if fitted) and retest the insulation resistance before use.

8.8.6.2 Dry with Hot Air

Direct the hot air from one or two 1 to 3 kW electrical fan heaters into the alternator air inlet. Make sure each heat source at least 300 mm away from the windings to avoid scorching or over-heating damage to the insulation. Air must flow freely through the alternator to remove the moisture.

After drying, remove the fan heaters and re-commission as appropriate.

If the generator set is not put into service immediately, turn on the anti-condensation heaters (where fitted) and retest the insulation resistance before use.

8.8.6.3 Plot Insulation Resistance (IR) Graph

Whichever method is used to dry out the alternator, measure the insulation resistance and temperature (if sensors fitted) of the main stator windings every 15 to 30 minutes. Plot a graph of insulation resistance, IR (y axis) against time, t (x axis).

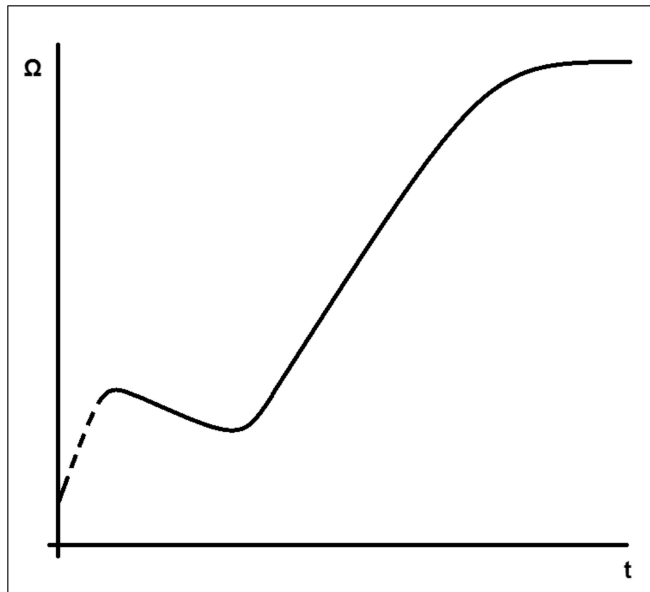

FIGURE 27. INSULATION RESISTANCE GRAPH

A typical curve shows an initial increase in resistance, a fall and then a gradual rise to a steady state. If the windings are only slightly damp the dotted portion of the curve may not appear. Continue drying for another hour after steady state is reached.

NOTICE

The alternator must not be put into service until the minimum insulation resistance is achieved.

-

This page is intentionally blank.

9 Parts Identification

9.1 S9 One Bearing Alternator

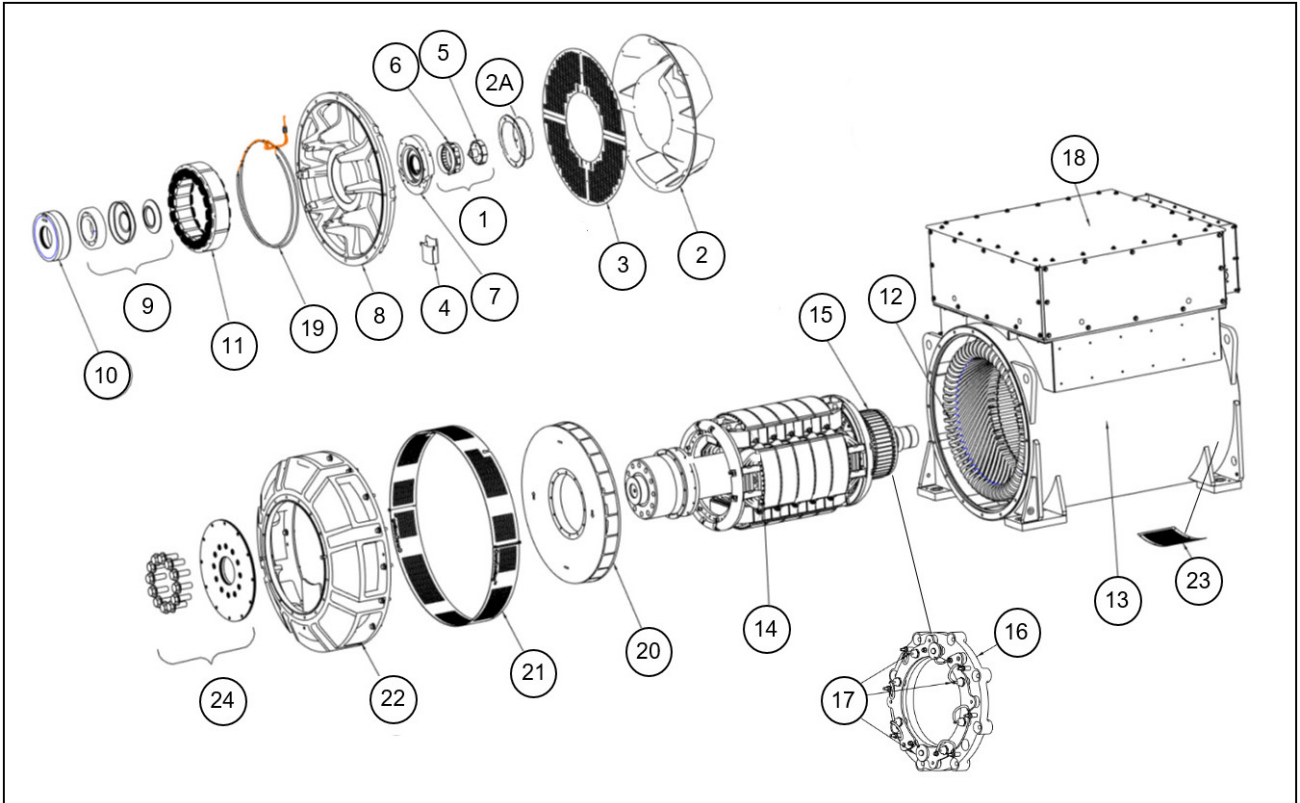

FIGURE 28. S9 ONE BEARING ALTERNATOR

9.2 S9 Two Bearing Alternator

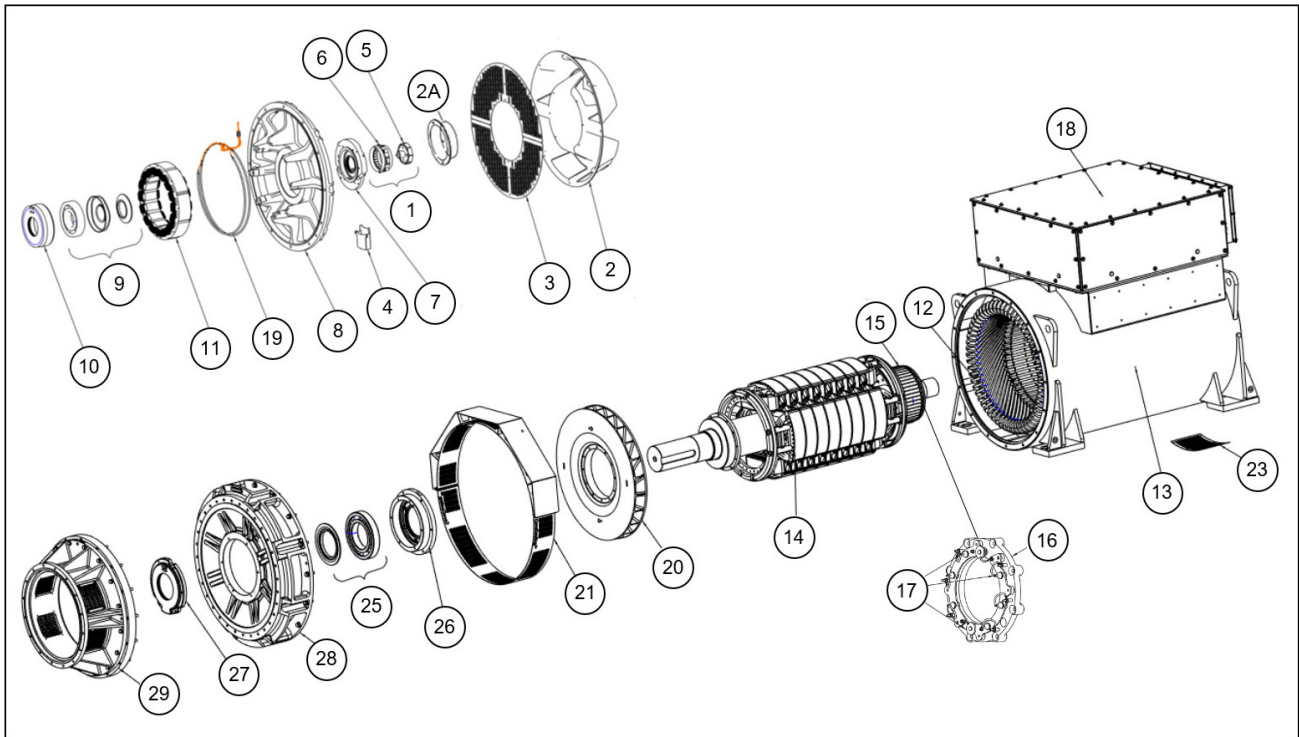

FIGURE 29. S9 TWO BEARING ALTERNATOR

9.3 S9 Medium and High Voltage Parts and Fasteners

TABLE 22. S9 PARTS AND FASTENERS

Reference	Component	Fastener	Quantity	Torque (Nm)
1	Complete PMG parts	-	-	-
2	Air Inlet Cover	M8 x 20	14	10
2A	PMG Cover	M5 x 12	4	5
3	Air Inlet Screen (axial)	M8 x 14	3	25
4	Grease Trap	M8 x 14	2	25
5	PMG Rotor	M10 x 100	1	48
6	PMG Stator	M6 Threaded Pillars	4	10
7	NDE Bearing Cap (A-F cores) NDE Bearing Cap (G-H cores)	M10 x 55 M12 x 55	4 7	48 84
8	NDE Bracket (mass 177 kg)	M16 x 60	12	206
9	NDE Bearing	-	-	-
10	NDE Bearing Cartridge (A-F cores) NDE Bearing Cartridge (G-H cores)	M10 x 55 M10 x 50	4 6	48 48

Reference	Component	Fastener	Quantity	Torque (Nm)
11	Exciter Stator (A-F cores)	M8 x 120	8	25
	Exciter Stator (G-H cores)	M8 x 150	8	25
12	Main Stator	-	-	-
13	Main Frame	-	-	-
14	Main Rotor	-	-	-
15	Exciter Rotor	-	-	-
16	Rectifier Assembly	M8 Stover Nut	8	20
17	Diode/Varistor	-	-	2.6 - 3.1
18	Terminal Box	-	-	-
19	Anti-condensation Heaters	M6 x 20	8	10
20	Fan	M10 x 110	12	45
21/21a	DE Air Outlet Screen	M8 x 25	4	25
22	DE Adapter (One Bearing)	M16x 55	16	206
23	NDE Air Inlet Screen (Radial)	M8 x 14	6	25
24	DE Coupling Discs (One Bearing) SAE18	M30 x 90	12	1350
	DE Coupling Discs (One Bearing) SAE21	M30 x 70	12	1350
25	DE Bearing (Two Bearing)	-	-	-
26	DE Bearing Cartridge (Two Bearing A-D cores)	M10 x 75	6	48
	DE Bearing Cartridge (Two Bearing E-F cores)	M12 x 90	6	84
	DE Bearing Cartridge (Two Bearing G-H cores)	M12 x 75	6	84
27	DE Bearing Cap (Two Bearing A-D cores)	M10 x 45	6	48
	DE Bearing Cap (Two Bearing E-F cores)	M10 x 45	6	48
	DE Bearing Cap (Two Bearing G-H cores)	M12 x 120	4	48
28	DE Bracket (Two Bearing)	M16 x 55	16	206
29	DE Adapter (Two Bearing)	M16 x 60	16	206

9.4 S9 Medium and High Voltage Terminal Box Parts and Fasteners

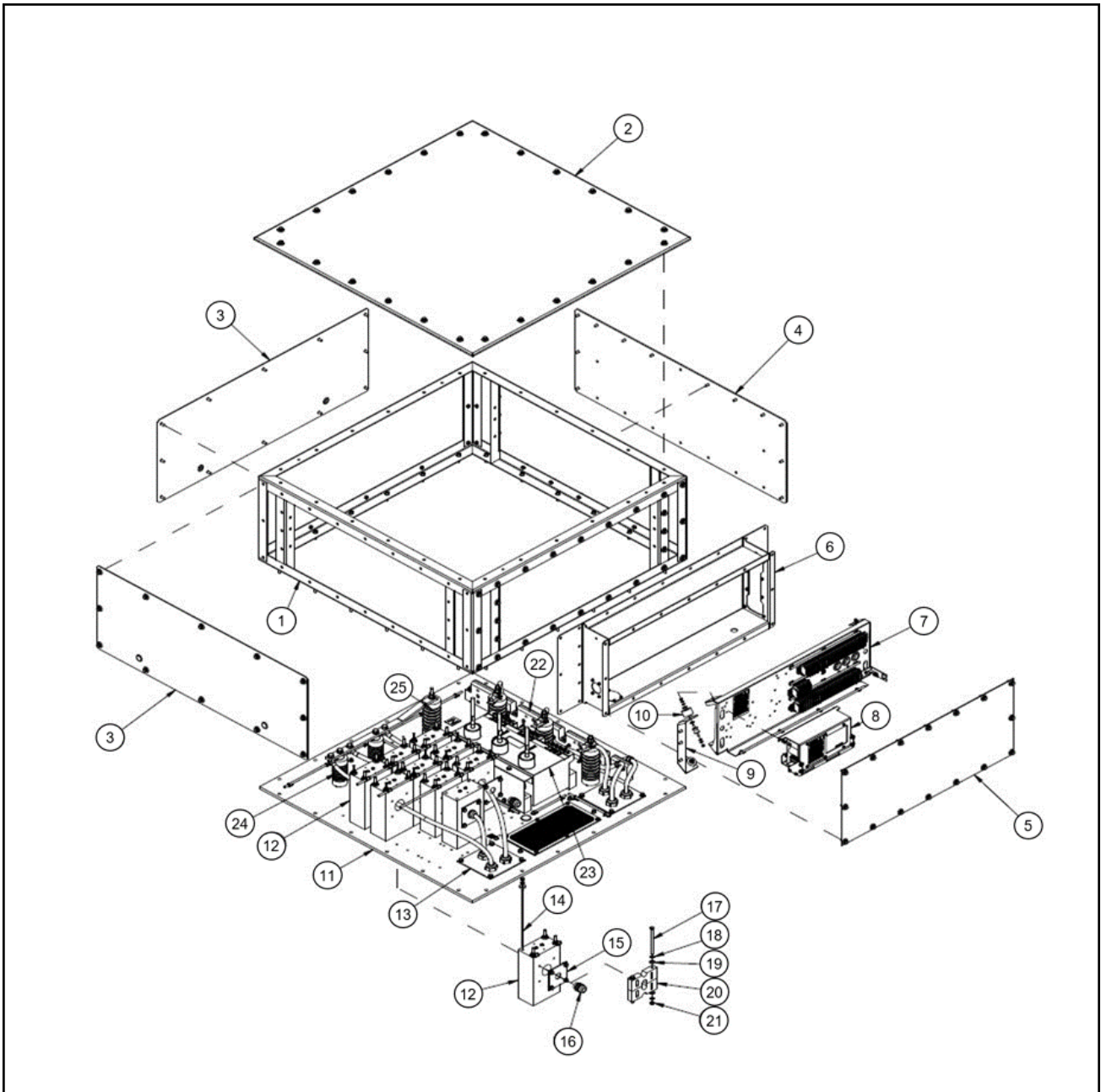

FIGURE 30. MEDIUM AND HIGH VOLTAGE TERMINAL BOX PARTS AND FASTENERS

TABLE 23. PARTS AND FASTENERS: S9 MV/HV TERMINAL BOX

Reference	Component	Fastener	Torque (Nm)
1	Terminal Box Frame	M8 x 35	25
2	Terminal Box Lid	M8 x 25	25
3	Terminal Box Panel	M8 x 25	25
4	Gland Plate	M8 x 25	25
5	Auxiliary Terminal Box Cover	M8 x 25	25

Reference	Component	Fastener	Torque (Nm)
6	Auxiliary Terminal Box	M8 x 25	25
7	Auxiliary Terminal Box Panel	M6	10
8	Automatic Voltage Regulator (AVR)	M6 x 16	10
9	Anti-Vibration Mount (AVM) Fixing Bracket	M8 x 25	25
10	AVM	M6	10
11	Terminal Box Base Plate	M8 x 35	25
12	Current Transformer (CT)	-	-
13	Gland Plate	M6 x 16	10
14	CT Stud	-	-
15	Gland Plate	M8 x 16	15
16	Cable Gland	-	-
17	Cable Clamp Bolt	M8 x 030	15
18	Washer, Belleville		-
19	Washer, Flat		-
20	Cable Clamp	-	-
21	Nut	M8	15
22	Cable Support	M8 x 70	15
23	Voltage Transformer (VT)	M8	15
24	Post Insulator to Base Plate	M12	90
25	Post Insulator to Base Plate	M12	90

-

This page is intentionally blank.

10 Technical Data

NOTICE

Compare measurements with the technical data sheet and the test certificate supplied with the alternator.

10.1 S9 Medium and High Voltage Winding Resistances

TABLE 24. S9 WINDING RESISTANCES (5/6 PITCH)

Alternator	Resistance of windings at 22 °C (measured values should be within 10%)								
	Main Stator (lead-lead) (Ohms)					Exciter Stator (Ohms)	Exciter Rotor, L-L (Ohms)	Main Rotor (Ohms)	PMG Stator, L-L (Ohms)
	51 (U1-U2) (V1-V2) (W1-W2)	61 (U1-U2) (V1-V2) (W1-W2)	63 (U1-U2) (V1-V2) (W1-W2)	83 (U1-U2) (V1-V2) (W1-W2)	91 (U1-U2) (V1-V2) (W1-W2)				
S9-A4	0.052	0.272	0.168	0.828	0.8940	9.8	0.028	0.48	3.8
S9-B4	0.0378	0.191	0.14	0.618	0.711	9.8	0.028	0.5	3.8
S9-C4	0.038	0.144	0.108	0.504	0.596	9.8	0.028	0.53	3.8
S9-D4	0.03	0.129	0.0905	0.409	0.497	9.8	0.028	0.57	3.8
S9-E4	0.0247	0.121	0.078	0.342	0.408	11.2	0.032	0.63	3.8
S9-F4	0.02	0.082	0.061	0.284	0.336	11.2	0.032	0.69	3.8
S9-G4	0.0172	0.0624	0.048	0.206	0.253	11.2	0.032	0.76	3.8
S9-H4	0.0132	0.058	0.042	0.188	0.218	11.2	0.032	0.81	3.8

TABLE 25. S9 WINDING RESISTANCES (2/3 PITCH)

Alternator	Resistance of windings at 22 °C (measured values should be within 10%)								
	Main Stator (lead-lead) (Ohms)					Exciter Stator (Ohms)	Exciter Rotor, L-L (Ohms)	Main Rotor (Ohms)	PMG Stator, L-L (Ohms)
	851 (U1-U2) (V1-V2) (W1-W2)	961 (U1-U2) (V1-V2) (W1-W2)	963 (U1-U2) (V1-V2) (W1-W2)	983 (U1-U2) (V1-V2) (W1-W2)	991 (U1-U2) (V1-V2) (W1-W2)				
S9-A4	0.0618	0.329	0.191	1.139	1.318	9.8	0.028	0.48	3.8
S9-B4	0.048	0.251	0.154	0.761	0.822	9.8	0.028	0.5	3.8
S9-C4	0.0366	0.196	0.132	0.598	0.687	9.8	0.028	0.53	3.8
S9-D4	0.037	0.143	0.111	0.505	0.577	9.8	0.028	0.57	3.8
S9-E4	0.0304	0.147	0.094	0.418	0.498	11.2	0.032	0.63	3.8
S9-F4	0.024	0.1	0.078	0.348	0.408	11.2	0.032	0.69	3.8
S9-G4	0.0205	0.0827	0.062	0.289	0.336	11.2	0.032	0.76	3.8
S9-H4	0.0172	0.066	0.047	0.208	0.252	11.2	0.032	0.81	3.8

11 Service Parts

Servicing and repairing your alternator with genuine STAMFORD® or AvK® parts is critical to the life and reliability of the product. For further parts information and details of your nearest outlet visit www.stamford-avk.com.

11.1 Parts Orders

When ordering parts the machine serial number or machine identity number and type should be quoted, together with the part description. The machine serial number can be found on the name plate or frame.

11.2 Customer Service

CGT service engineers are experienced professionals, trained extensively to deliver the best support possible. Our global service offers:

- On-site AC alternator commissioning
- On-site bearing maintenance & bearing condition monitoring
- On-site insulation integrity checks
- On-site AVR & accessories set-up

For details of your nearest service outlet visit www.stamford-avk.com.

11.3 Recommended Service Parts

In critical applications a set of these service spares should be held with the alternator.

TABLE 26. S9 HIGH VOLTAGE SERVICE PARTS

Part	Number
DECS-100-B11 (if fitted)	A054S072
DECS-150 AVR (if fitted)	A060B914
DM110 AVR (if fitted)	E000-23800
DM810 (if fitted)	A061D996
UNITROL 1010 (if fitted)	Contact CGT
DVC310 (if fitted)	A062K080
Rectifier replacement kit (6 diodes, 2 varistors)	A063M677
PMG repair kit	45-1082
Kluberquiet BQ 72-72 grease (400g)	A053Z748
S9 One Bearing	
Regreasable NDE bearing kit complete with cap and cartridge (A-E core lengths)	45-1118
S9 Two Bearing	
Regreasable NDE bearing kit complete with cap and cartridge (A-F core lengths)	45-1118

Part	Number
Regreasable NDE bearing kit complete with cap and cartridge (G-H core lengths)	A063M672
Regreasable DE bearing kit complete with cap and cartridge (A-D core lengths)	45-1119
Regreasable DE bearing kit complete with cap and cartridge (E-F core lengths)	45-1120
Regreasable DE bearing kit complete with caps and cartridge (G-H core lengths)	A063M671
Regreasable NDE and DE bearing kit complete with caps and cartridges (A-D core lengths)	45-1151
Regreasable NDE and DE bearing kit complete with caps and cartridges (E-F core lengths)	45-1152
Regreasable NDE and DE bearing kit complete with caps and cartridges (G-H core lengths)	A063M674

12 End of Life Disposal

12.1 General Guidance

When disposing of an alternator, component parts or packaging:

- When processing waste materials obey applicable rules and regulations.
- Process waste in an environmentally responsible manner, reuse, reclaim and/or recycle materials where applicable.
- If necessary, speak to a waste processing company for advice and/or guidance.

12.2 Packaging Material

After the alternator, replacement components or service items have arrived, the packing material must be disposed of.

- Wooden packaging must be recycled. However, wood treated with preservative chemicals must be processed appropriately. **Do not burn chemically treated wood.**
- Plastic packaging must be recycled.
- Paper and cardboard packaging must be recycled.
- Anti-corrosion agents can be removed using a cleaning agent and a cloth. The cloth must be disposed as contaminated waste, refer to [Section 12.4 on page 82](#).
- Desiccants/drying agents must be disposed of as hazardous waste, refer to [Section 12.4 on page 82](#)

12.3 Recyclable Material

Separate items containing recyclable base materials, such as: iron, copper and steel, by removing non-recyclable and/or hazardous materials from alternator components.

- Items containing: iron, steel and copper can now be recycled via specialized material recycling companies.
- Separate the removed material into hazardous waste and non-hazardous waste. Obey applicable rules and regulations.
 - Dispose of any contaminated and/or hazardous materials as hazardous waste, refer to: [Section 12.4 on page 82](#).
 - Non-hazardous materials that cannot be reused, re-purposed or recycled can now be processed as general waste.

12.4 Hazardous or Contaminated Waste

⚠ CAUTION

Hazardous Substances

Hazardous substances can cause minor or moderate injury. Prolonged or repetitive exposure to hazardous substances can cause serious medical conditions. To prevent injury:

- ***Always read and obey the instructions provided by the product manufacturer.***
- ***Use, handle and store substances as specified by the product manufacturer.***
- ***Always wear appropriate personal protective equipment, refer to Safety Precautions Chapter.***

Waste materials such as, but not limited to: oil, grease, lubricant, fuel, adhesive, desiccants (drying agents), battery acid, cleaning agent, solvent or corrosive substance, paint, polyester resin and/or plastic residues or articles contaminated with such substances are designated as 'Hazardous Waste' by international regulations.

- Obey applicable rules and regulations when handling, storing, transporting, processing and/or disposing of hazardous waste.
- If necessary, speak to a hazardous waste disposal company for assistance and/or advise in the disposal of hazardous waste or contaminated articles.

