

Cummins Data Classification:
Cummins Confidential

This document (and the information shown thereon) is **Confidential and Proprietary** and shall not be disclosed to others in hard copy or electronic form, reproduced by any means, or used for any purpose without written consent of Cummins Inc.

Part Number: **A057G567** Part Revision: **C**
Part Name: **ARRANGEMENT, GENERATOR ROTOR TORSIONAL**
Drawing Category: **Outline State: Released** Sheet 1 of 2



Part Number: A057G567

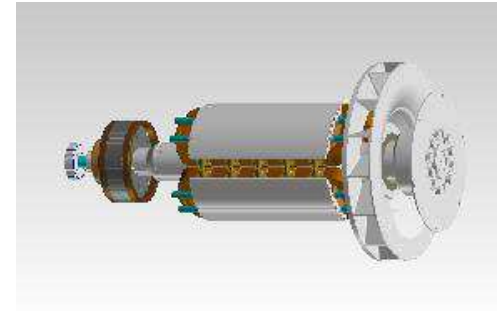

3D image provided when available for visual reference only.

Change Notice	CN00077355	Alternates	
Manufacturer Part (MEP)	No	Usage	Production Only
Release Phase Code	Production (P)	Drawing Specification	Number: DS47118972
External Regulations	No External Regulation		Revision: A

Drawing Revision Information

<p>Description of Change(s) Note: Change information is provided for reference only and does not supersede the drawing's primary content.</p>
<p>MINOR AMENDMENTS</p> <p>ADMINISTRATIVE CHANGE(S) TO PART ATTRIBUTES, BILL OF MATERIAL, OR ASSOCIATED SPECIFICATIONS.</p>

Drawing Authorization

Drafter	Aishwarya Rajaram Shelar	Date	10JAN2023
Checker	Kuldeep Dilip Pawar	Date	10JAN2023
Approver	NO APPROVAL REQUIRED	Date	

Document Generated: 10JAN2023 10:12 GMT