

12	11	10
CORE	WEIGHT(KG)	C OF G
C	1887	622
D	1943	644

DISC COUPLINGS					
SAE NO.	AN	AR	AS	AT	V
14	25.4	8	∅13.5	438.1	∅466.67
18	15.87	6	∅16.7	543	∅571.45

NOTE:
 1. CUSTOMER MUST ENSURE THAT AIR INLET AND OUTLET POSITIONS ARE NOT OBSTRUCTED
 2. CUSTOMER MAY CUT CABLE ENTRY HOLES AS REQUIRED IN ANY OF THE FOUR TERMINAL BOX SIDES. SUBJECT TO POSITION OF AVR, TERMINALS, ETC

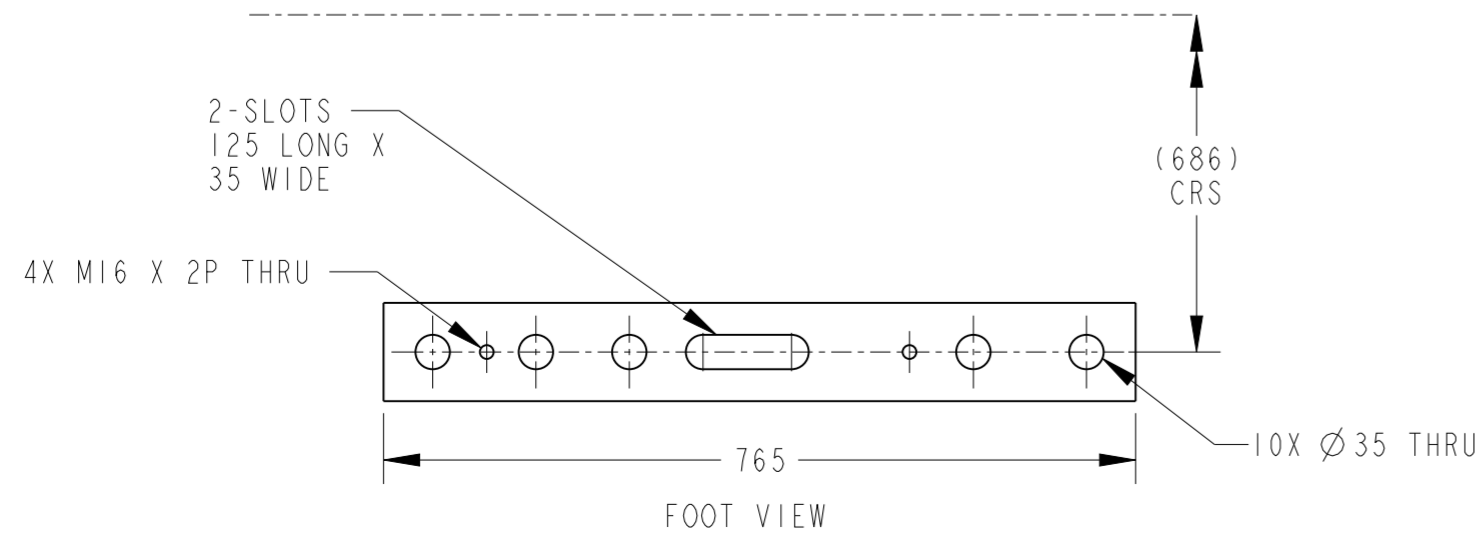
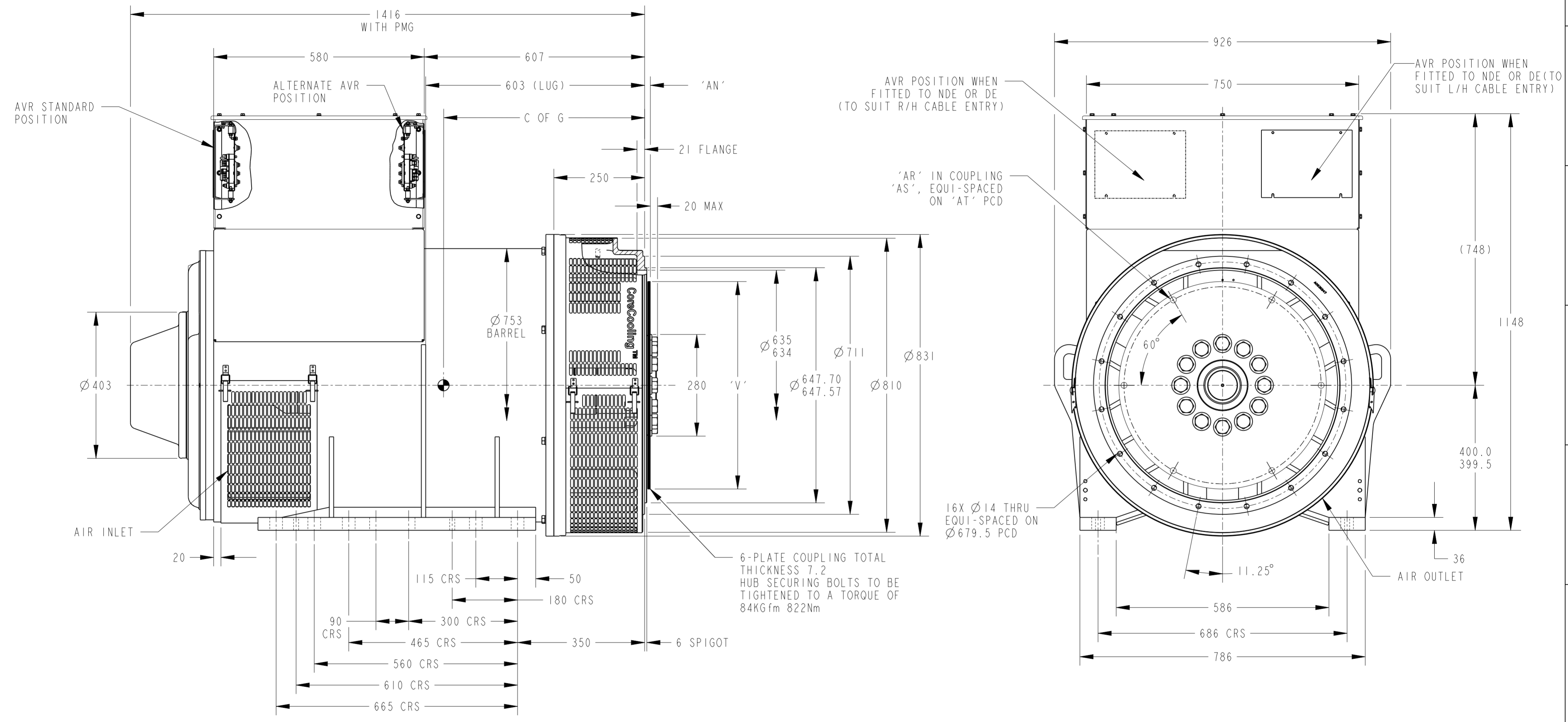

PART NUMBER: A074W893	PART REVISION: B
PART NAME: ARRANGEMENT, GENERATOR GENERAL	
DRAWING CATEGORY: OUTLINE	
STATE: RELEASED	SHEET: 1 OF 2
CUMMINS DATA CLASSIFICATION: CUMMINS CONFIDENTIAL	
THIS DOCUMENT (AND THE INFORMATION SHOWN THEREON) IS CONFIDENTIAL AND PROPRIETARY AND SHALL NOT BE DISCLOSED TO OTHERS IN HARD COPY OR ELECTRONIC FORM, REPRODUCED BY ANY MEANS, OR USED FOR ANY PURPOSE WITHOUT WRITTEN CONSENT OF CUMMINS INC.	

DRAWING SPECIFICATION DESCRIPTION		
S6LID, C/D-CORE, IB, SAE0-14/18, VANE ADAPTOR, STD BOX		
DIMENSIONS ARE IN: MILLIMETERS [] ARE IN: -	SIZE: A2 SCALE: 0.200	
DIMENSIONING AND TOLERANCING PER: ASME Y14.5-2009		
		CAD SYSTEM PTC® Creo® Parametric

4

3

2

1

D



Part Number: A074W893

Change Notice	CN00132569	Alternates	
Manufacturer Part (MEP)	No	Usage	Production Only
Release Phase Code	Production (P)	Drawing Specification	Number: DS47138970
External Regulations	No External Regulation		Revision: B

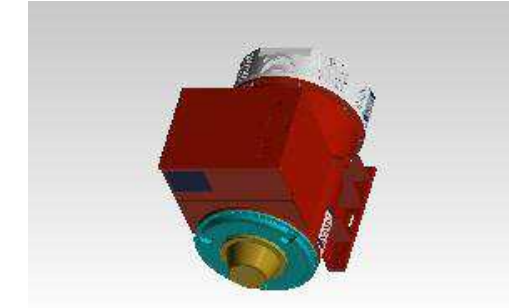

3D image provided when available for visual reference only.

C

Drawing Revision Information

Description of Change(s) Note: Change information is provided for reference only and does not supersede the drawing's primary content.
1. PRODUCTION RELEASE 2. BORDERLINE UPDATED

Drawing Authorization

Drafter	Akshay S Jadhav	Date	02APR2024
Checker	Umesh Krushnrao Dagwale	Date	02APR2024
Approver	Kotresh Shivakavi	Date	02APR2024

B

A

Cummins Data Classification: **Cummins Confidential** This document (and the information shown thereon) is **Confidential and Proprietary** and shall not be disclosed to others in hard copy or electronic form, reproduced by any means, or used for any purpose without written consent of Cummins Inc.

Part Number: **A074W893** Part Revision: **B**
 Part Name: **ARRANGEMENT,GENERATOR GENERAL**
 Drawing Category: **Outline** State: **Released** Sheet 2 of 2

4

3

2

1