



Application Guidance Notes: Technical Information from STAMFORD | AvK

AGN 238 – General Application and Operational Conditions for STAMFORD® Alternators

CONTENTS

Application and Operational Conditions

Thermal Damage Risks
Earthing and Neutral Referencing of Generator
Voltage Transient Risks
Current Transient Risks
Preventable Current Transient Risks
Loss of Synchronisation
Non-preventable Current Transient Risks
Vibration Levels
Bearings
Humidity
Operating Manual

Practical Guidance to On-site Operating Conditions and Impacts to Alternators - Summary

Safety Notice
Alternator Operating Voltage and Frequency Range
Alternator Rating
Basic Continuous Rating (BR)
Peak Continuous Rating (PR)

Overload
Power Factor
What Causes Power Factor
Load Sharing
Cooling Air for an Alternator
Ambient Temperature
Airflow Through the Alternator
Airflow Requirements
Alternator Air Filters
Environmental Conditions
IP Codes
Ratings on STAMFORD Alternators
Environmental Operating Conditions

SCOPE

These Application and Operational Conditions apply to STAMFORD | AvK, STAMFORD low voltage alternators, in applications that are not governed by international or national Grid Codes.

In general, the alternator will be operated within the performance parameters stated in IEC 60034-1:2010.

These conditions must be followed in conjunction with the STAMFORD alternator's Owner's Manual.

THERMAL DAMAGE RISKS

There is a risk of thermal damage to the alternator if any of the following circumstances are true for the application or environment in which the alternator is being used.

- The generating set equipment package is being operated in close proximity to plant or equipment such that it is at risk of exhaust and/or hot air being carried into the cooling air intake.
- The alternator air inlet temperature exceeds 40°C.
- The alternator system voltage is operated beyond Zone A voltage limits (+/-5%) as specified in IEC 60034-1:2010 Section 7.3.
- The alternator system frequency is operated beyond Zone A frequency limits (+/-2%) as specified in IEC 60034-1:2010 Section 7.3.
- The alternator is operated at an altitude exceeding 1000m above sea level.
- The alternator or the generating set equipment package is operated with air inlet filters, due to a high risk of solid or liquid contaminants in the alternator cooling air supply.

- The alternator is operated with a cooling air supply less than the free volume quoted in the alternator's technical data sheet.
- The alternator is operated in an overload condition exceeding that specified in IEC 60034-1:2010.

If any of the above conditions are true, then the following conditions (A-C) will apply:

- A.** Based on IEC 60034-1:2010 Section 8.6.3.1, embedded RTDs must be used in conjunction with an operating control system configured to Trip at 155°C.
- B.** The operating control system must include a pre-trip Alarm setting 5°C below the Trip temperature to guard against unexpected Trip events.
- C.** In the event of an Alarm condition, the customers on site operating procedures must prescribe corrective actions to manage the alarm condition to ensure trip levels are avoided. Those actions must be taken and may include, but are not restricted to, changing filters, removing restrictions to cooling air, or reducing the alternator output current.

EARTHING AND NEUTRAL REFERENCING OF ALTERNATOR

Appropriate earthing and neutral referencing of a LV alternator provides a fundamental method of restricting the magnitude of imposed potential voltage differences across the stator winding assembly.

- The installer of a generating set equipment package must ensure the neutral and earthing arrangements for the alternator are compatible with the earthing arrangement of the electrical network to which that generating set equipment package is to be connected.
- Earthing arrangements must be mechanically robust and protected from any degradation that affects electrical continuity in line with local grid / network connection standards where available, and at least in accordance with BS7430:2011 Code of practice for protective earthing of electrical installations.
- If the generating set equipment package is operating in parallel with a supply system which is either, un-earthed or earthed through fault limiting impedance, then a means of detecting abnormal earth fault conditions must be incorporated within the generating set equipment package.

VOLTAGE TRANSIENT RISKS

High voltage transients will, over time, degrade any insulation system. The STAMFORD low voltage ($\leq 1\text{kV}_{\text{rms}}$) alternator insulation system is designed to withstand peak transient voltage levels up to and including 1.3kV in accordance with IEC 60034-17, Figure 7 - Limiting curve of admissible impulse voltage U_{LL} .

- The customer must ensure that the level of voltage transient does not exceed 1.3kV in accordance with IEC 60034-17, Figure 7.

CURRENT TRANSIENT RISKS

High current transients cause high mechanical forces between conductors, coil groups and phases. These mechanical forces can lead to insulation damage, which in turn may lead to machine failure. In addition, high current transients can result in high torque transients impacting both static and rotating components.

Current transients fall into two classes: Preventable and Non-preventable

Preventable Current Transient Risks

The installation must be capable of limiting the magnitude and duration of excessive current transients resulting from Step Load Changes.

Synchronisation:

- The current transient associated with synchronising individual generating sets with the network, or groups of generating sets with the network, must be managed by an effective synchronising system. The current transient resulting from synchronisation must not exceed 1.0 times full load current.
- A synchronisation event at point of closure being within the following limits will achieve this requirement:
 - Phase angle; within +/- 10 degrees electrical,
 - Voltage match; within +/- 0.5% system voltage level,
 - Slip rate is within 0.1Hz/sec.

Loss of Synchronisation

- To avoid the damaging effects encountered due to loss of synchronisation, a protection scheme must be in place with the ability to detect system disturbances and disconnect the generating set.

Non-preventable Current Transient Risks

Some network faults can cause very high current transients.

- It is accepted that protection systems cannot prevent the first few cycles of high current transients, as conventional electro-mechanical switchgear takes at least 120ms to disconnect. During that time at least 6 cycles of high current transients with associated torque pulsations have been endured. Each has the ability to cause damage to the wound assemblies.
- It is the duty of the generating set installer to understand the operational and fault clearing characteristics of the network to which a generating set is connected.
- When a current transient exceeds 4.5 times the value of the alternator rated full load rms current, the generating set must be disconnected until system stability is restored. Before re-connection, the protection and control systems of the generating set must be verified as being within operational parameters.

VIBRATION LEVELS

STAMFORD alternators are designed to withstand vibration levels encountered on generating sets built to meet the requirements of ISO 8528-9. As described in the Owner's Manual and AGN 008.

- Within the frequency envelope of 2Hz -300Hz, the vibration levels imposed on the alternator by the generating set equipment package must not exceed:
 - Vibration Displacement (S rms): 0.32mm
 - Vibration Velocity (V rms): 20mm/sec
 - Vibration Acceleration (a rms): 13m/sec²

BEARINGS

A maintenance programme of bearing assessment must be in place to ensure reliable bearing operation.

Alternators with re-greasable bearings are supplied with information labels, which advise the user of grease type, re-lubrication frequency and quantity of grease to be used. The instructions are described in the Owner's Manual and must be followed. The grease used is a high specification synthetic compound that must not be mixed with grease of a different specification.

HUMIDITY

If the Relative Humidity (RH) in which the alternator is operating is expected to be $\geq 70\%$, then factory specified anti-condensation heaters must be installed. In these conditions, the anti-condensation heaters must be energised when the alternator is in service, but not operating, to keep the alternator windings above dewpoint.

OPERATING MANUAL

The customer supplied manual for the generating set equipment package, must incorporate the **STAMFORD**[®] alternator's Owner's Manual, where fundamental information regarding ac generator (alternator) care is provided.

The site operating procedures must include the necessary guidance and instructions to ensure the prevailing site conditions are appropriately considered and the necessary maintenance regime is being applied.

PRACTICAL GUIDANCE TO ON-SITE OPERATING CONDITIONS AND IMPACTS TO ALTERNATORS - SUMMARY

This section has been developed as a practical guide for customers on site operations and maintenance staff, to support an increase in awareness of the impact and management of

operational conditions and the minimising impact on the operational life of STAMFORD and AvK branded alternators of those site conditions.

The content was derived from **Cummins Generator Technologies** in-use Application Guidance Notes, as contained on the STAMFORD | AvK web site:

<https://www.stamford-avk.com> and is an abridged version of the content of those AGN's, to support operational staff in managing site operating conditions.

Safety Notice:

No guidance is offered or implied with respect to required Health and Safety procedures, processes and country/regional / international requirements. It is expected that all persons working on site based equipment is permitted to do so, based on the installed equipment owner's approval and permission for working access.

Refer to site specific requirements and the authorised person / Senior Authorised person, before any access to plant and equipment, or work / assessment activity is started.

As a minimum, Cummins Employees must comply with Cummins Electrical Safety Rules, or higher rules where they exist.

Alternator Operating Voltage and Frequency Range

Alternators utilize wound rotor and stator components to develop rotating electromagnetic fields, induced in static wires to develop and AC output voltage. Main rotor windings, as the name suggests, are rotated around a shaft common axis, and for example, for a 4 pole rotor, under rotation passing a stationary point, the magnetic field can be identified as changing polarities, in sequence, north, south, north, south, so that the speed of rotation, for instance shaft speed rotating at 1500RPM, multiplied by the number of pole pairs, (In a 4 pole rotor that is 2 pole pairs), then all divided by 60 seconds will define the electrical frequency in cycles per second. Of course, in 3 phase alternators, the stator windings are distributed in such a way that all three phases have conductors having a voltage induced in relative position.

Main stator windings are the static wires that are housed in the iron core, in slots, and configured in a range of coil, group and phase connections, which are designed to optimise the available active materials and develop a defined electrical output.

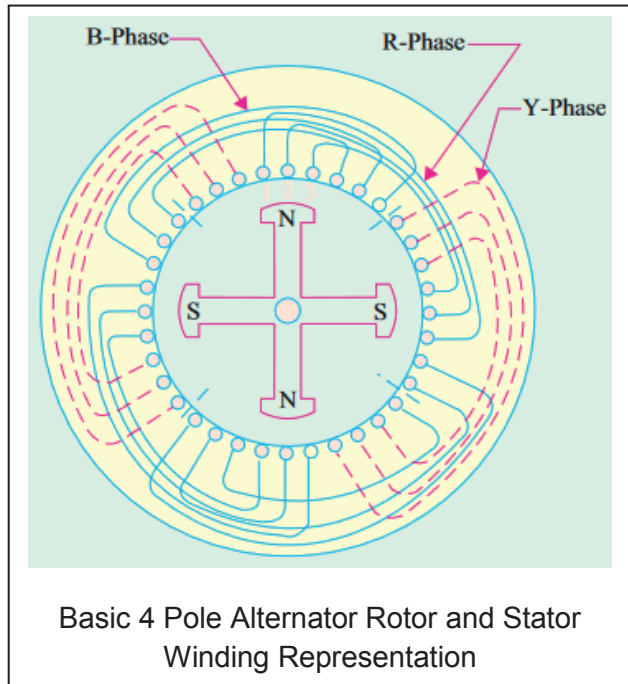

To achieve optimum performance from a winding design, the ideal situation is to operate the alternator at the specified voltage and frequency (V & Hz), called out on the rating plate. If this is done, the output KVA, at given power factor will always be optimized.

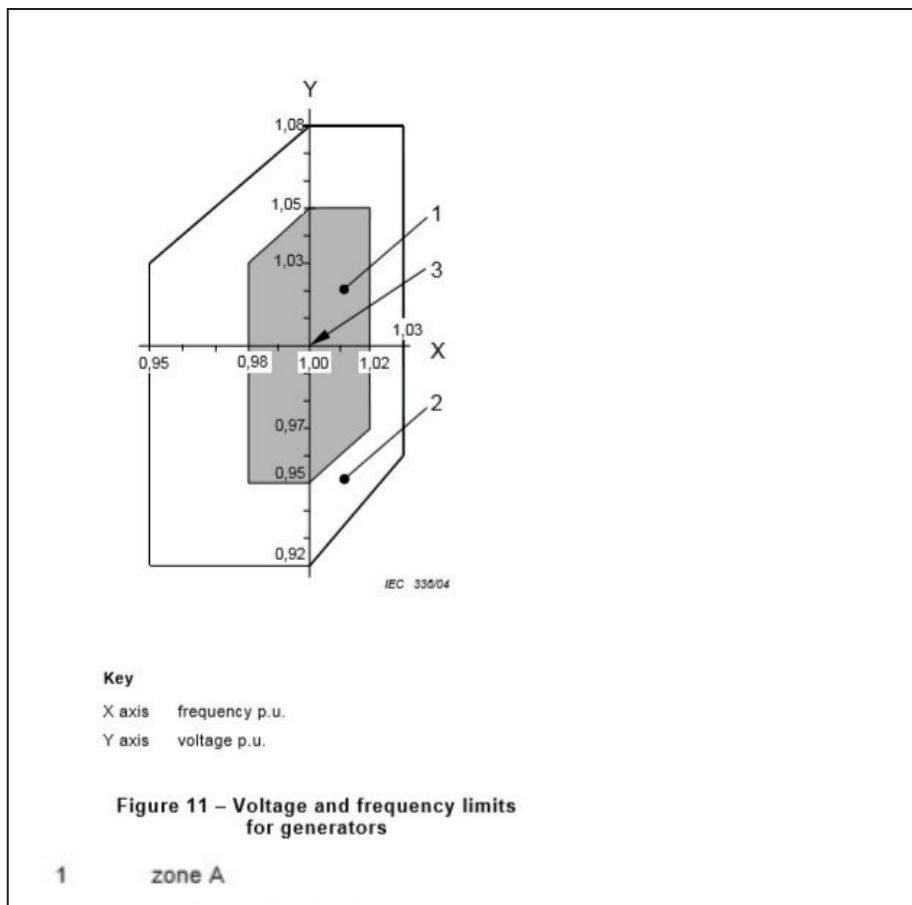

When looking at the international design standards common in rotating electrical machines for rating, IEC 60034-1:2010, there is an easy graphical representation of operational frequency and voltage envelopes, as shown on the previous page, around the nominal Voltage and Frequency rating points (crossing points in the target for operation), with zones to identify the variance of operation.

The closer the machine is operated to the centre crossing point of Voltage and Frequency, the less impact may be seen on temperature that each wound component runs at for a continuous load condition. If the alternator is operated away from the centre, there will be some impact to either 1 or both main wound assemblies, resulting in higher peak temperatures, and a potential reduction in operational life.

There are just two operating frequencies associated with power distribution in worldwide AC grid networks, 50Hz and 60Hz.

There are many countries around the world that operate at different voltages. It is important to ensure that a generating set, which is designed to operate at a given voltage and frequency. Some designs of alternators can accommodate a wide range of system voltages, but some are very limited. Always check the alternator rating plate to confirm how the machine will operate.

It may be possible to reconfigure the stator winding to meet the power system requirements, or alternatively, if not, it may be possible to utilize a de-rate factor to allow operation at conditions less than optimal. Always ask and confirm the alternator voltage and frequency rating capability to operate at a voltage level outside the designed bandwidth.

To cope with the wide variety of combinations of voltage and frequency used in different national systems, every alternator in the STAMFORD and AvK ranges may have several different winding designs.

Alternator Rating

Alternator ratings are specified in accordance with national and international Standards, IEC 60034-1 for alternators and (IEC 60034-22: AC generators for reciprocating internal combustion (RIC) engine driven generating sets). There are two types of rating that are specified, Basic Continuous Rating (BR) and Peak Continuous Rating (PR).

Basic Continuous Rating (BR)

This is a maximum continuous rating derived for continuous running duty. The alternator will have a maximum continuous rating at which the machine may be operated for an unlimited number of hours per year, while meeting the thermal operational temperatures laid down in requirements of the appropriate standards.

This drives an assessment of thermal stress and therefore insulation system life (how long the alternator is designed to operate for at the given rated continuous load before the insulation fails).

For industrial use alternators, three Base Continuous Rating levels are offered, based on temperature rise limits and a standards ambient temperature of 40°C:

- Class “H” (125°C/40°C) □ Class “F” (105°C/40°C) □ Class “B” (80°C/40°C)

Peak Continuous Rating (PR)

Peak continuous rating is also known as Standby Rating or Peak Standby Rating, and represents the absolute maximum load rating which the alternator can be run at, but with the recognition that the insulation life will be significantly reduced as the higher rating causes higher operating temperatures in the windings, resulting in accelerated thermal degradation.

The increased rating from base continuous rating will reduce the lifetime of the alternator by a factor of between 2 to 6 times.

There are variations on the two main ratings, which involve definitions of continuous and discontinuous load factors, as generating set builders optimise cost effective solutions to meet market needs. Some will also identify limited number of operating hours at that identified kVA rating, to limit thermal degradation, especially for well-defined standby applications.

The following table summarises the rating definitions in ISO8528-3 and IEC 60034-1 for the Alternator and ISO 8528-1 for the Generating Set:

Genset Rating (ISO8528-1)	Emergency Standby Power (ESP)	Limited Time Prime (LTP)	Prime Rated Power (PRP)	Continuous Operating Power (COP)
Load type	Variable	Constant	Variable	Constant
Annual operating hours	200	500	Unlimited	Unlimited
Average load	70%	100%	70%	100%
Overload	No	No	10% (1 hour in every 12 Hrs)	No
Alternator Rating (NEMA MG1-32)	Standby	Standby	Continuous	Continuous
Duty Cycle (IEC 60034-1)	S10	S10	S1	S1
Alternator Ratings	Standby 150/40 Standby 163/27	Standby 150/40 Standby 163/27	Class H 125/40 Class F 105/40 Class B 80/40	Class H 125/40 Class F 105/40 Class B 80/40

Summary of various International Standards Ratings for Alternators and Generating Sets

It is always suggested that the specific alternator Nameplate is checked to ensure the rating and duty are clearly understood.

Overload

If an alternator is operated above its designed base continuous rating, the operating temperatures will increase to a level that will degrade and so, shorten the life of, the wound components of the insulation system.

For a fixed percentage overload, the rate at which the operating temperatures increase is a product of the alternator's Thermal Time Constant. This thermal time constant factor varies in proportion to:

1. The physical mass of the wound components, which in turn affects the rate of thermal rise. For example; larger alternators up to 300kVA cope better with overloads than small alternators with outputs around 50kVA.
2. The percentage level of overload above the alternator's designed Class 'H' rating.
3. The duration of the overload condition.
4. The operating temperature of the wound components just before the overload condition begins.
5. The ambient temperature during the overload condition.

Ultimately, thermal overload should be avoided where at all possible. In all cases and as a general practical rule of thumb, continuous overload above 110% of the alternator Nameplate, applied for longer than 1 hour, will cause accelerated thermal degradation and bring about earlier end of life condition. Also, be aware that the relationship of overload and thermal degradation is not linear.

The rule of thumb for insulation design life is, the life of the insulation system is halved for every 10 Degrees higher thermal operating condition.

This importantly applies for every condition of increasing thermal stress. If for instance the ambient temperature is 10 Degrees hotter than the ambient for rating, say 50 Degrees at the air inlet, and the alternator is run with restricted cooling air due to the generating set air filters being partially clogged, and the alternator is running at 110% of rated load, there is every likelihood that the thermal degradation can be accelerated, reducing the design life from say 40,000 Hours to less than say 5,000 Hours.

Example: with 3 thermal acceleration factors:

40K design life:

$40K / 2 [10\% \text{ overload}] = 20K$

$20K / 2 [10\text{Deg increase in ambient temperature}] = 10K$

10k / 2[restricted air flow reduces effective cooling] = 5K

The result is total operational life reducing to around 0.8 years, (based on average 6K per year) of life from the nominal 8 years.

The above illustration details only 3 of the many possible factors impacting thermal insulation life of the alternator

Power Factor

Power factor is a way of identifying the electrical relationship between the active real power, also known as working power (**kWe**), required to do the job, and the consumed apparent power (**kVA**). The difference being due to the electrical characteristics of the electrical load applied to the alternator.

In electrical engineering terms, the power factor of an a.c. power system is the ratio of the real power (**kWe**) flowing to the load to the apparent power (**kVA**) in the electrical circuit.

The nature of the load in an a.c. circuit will determine if the current drawn is in phase or out of phase with the generated voltage. The load again determines if that current waveform 'leads' the voltage waveform or 'lags' the voltage waveform. For normal industrial loads (e.g. motors) the current will lag the voltage by some time interval or phase angle. The optimum situation is where current and voltage are in phase. This makes the power factor unity (1.0) and hence the real power (**kW**) the same as the product of voltage and current (**kVA**). Conventionally, alternator kVA ratings are based on a lagging power factor of 0.8. In this case the current will lag the voltage by an amount that causes the real power level supplied (**kW**) to fall below the kVA level by a factor of 0.8 times.

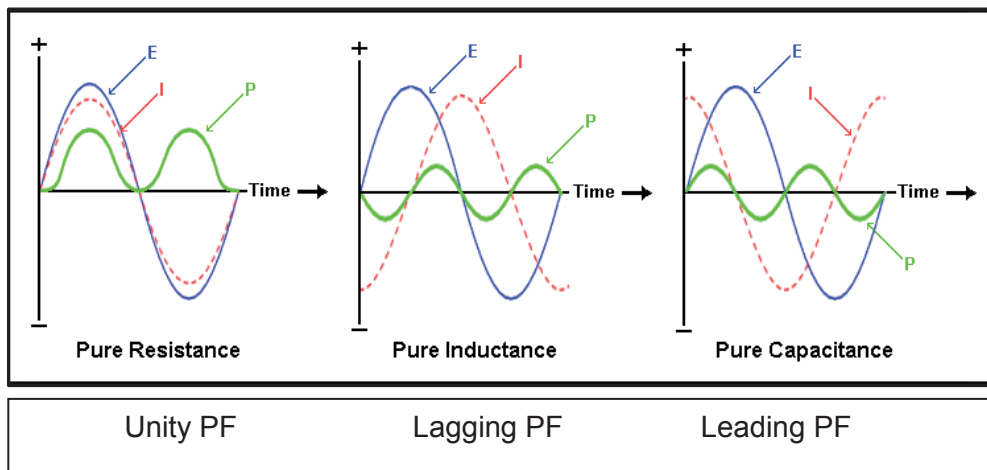

What Causes Power Factor?

Power factor basically is a measurement of the timing - phase angle difference - of the current waveform relative to the voltage waveform. The idea being to identify how effectively the

supplied power (**kVA**) is working in relation to the real work being done (**kWe**). The power is being used more effectively when the power factor is closer to unity.



It is possible for a load to demand a current that is almost totally out of phase with the generated voltage. Also, that current may be lagging the voltage (inductive or motor loads) or leading the voltage (capacitive loads).

When operating in parallel, care must be taken to manage power factor to ensure the generating set alternator is not overloaded.

When choosing to operate the generating set at power factors away from the range of 1.0 (Unity) to 0.8PF lagging, it is very easy to thermally overload the alternator by running a low lagging PF, as even though only a small real power (**kW**) is demanded by the load, which is well within the machines capability, damage can easily result if the load is a very low power factor load demanding a very high kVA level, and so result in very high alternator phase current.

Load Sharing

While the active power (**kWe**) sharing between generating sets during parallel operation is governed by the engine control systems, the reactive power (**kVAr**) sharing is controlled by the alternator's control systems.

There are various recognised load sharing methods in the generator industry, such as isochronous load sharing, cross-current compensation and quadrature droop load sharing.

Quadrature droop load sharing is the standard kVAr load sharing method utilised by STAMFORD | AvK. For AvK and STAMFORD alternators, quadrature droop load sharing requires a Droop Current Transformer (CT) to be fitted on one of the alternator's output phases. For AvK and STAMFORD alternators fitted with digital Automatic Voltage Regulator's (AVR), the quadrature droop should be programmed on installation. For STAMFORD alternators fitted with analogue AVRs, the CT secondary winding should be connected to the AVR droop S1 - S2 inputs.

The current signal from the Droop CT secondary winding is converted to a voltage signal across a burden resistor within the AVR. This voltage signal is then added vectorially to the

AVR sensing voltage so that the AVR will be “tricked” to droop the voltage by adjusting the excitation levels accordingly, in proportion to the levels of load current and power factor.

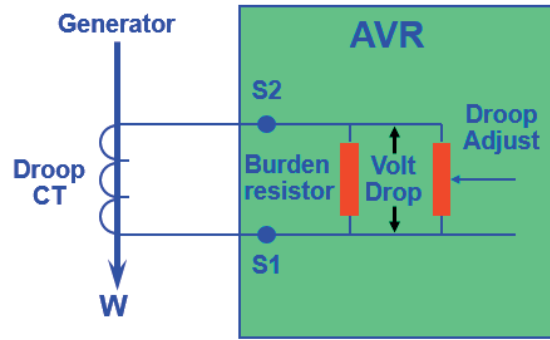

Example of AVR and Quadrature Droop CT Connection

It is important to have the droop CT on the same phase and the same AVR droop setting for all paralleled alternators (usually 3% at 0.8pf) to ensure proportional kVAr sharing among the Generating Sets.

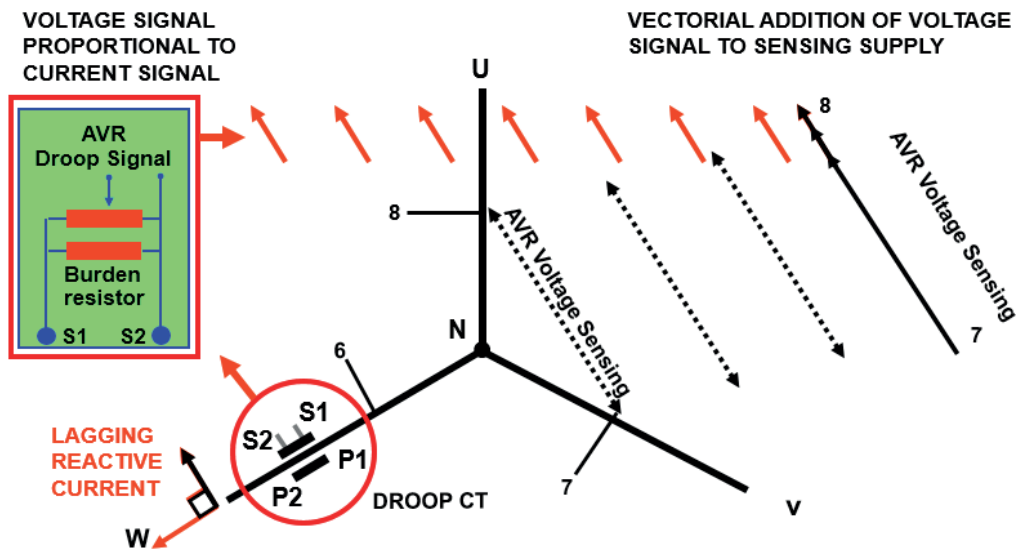

Example of vectorial addition of droop signal to the AVR sensing voltage

Because the percentage ‘droop’ of the output voltage is related mainly to the reactive component of the load current, the droop is negligible when the load current is at unity power factor. For this reason, any attempt to check the operation of the ‘droop’ characteristic by testing with a resistive load bank will not result in any observed ‘droop’ in the generating set’s output voltage.

When considering setting the generating set alternator quadrature droop circuit, please refer to the Owner’s Manual. It is vital that you understand all controls and settings before any adjustment is made. It is very easy to trip a generating set when operating in parallel with only very small adjustments, depending on the installed generating set protection settings.

Cooling Air for an Alternator

Both open air ventilated alternators and enclosed alternators with cooling sub-systems, must have a cooling system that operates at a certain temperature and volume of air through the alternator, to cool the components to a satisfactory temperature so that alternator does not overheat. The temperature that must be maintained is influenced by the air surrounding the alternator. This is commonly referred to as ambient temperature.

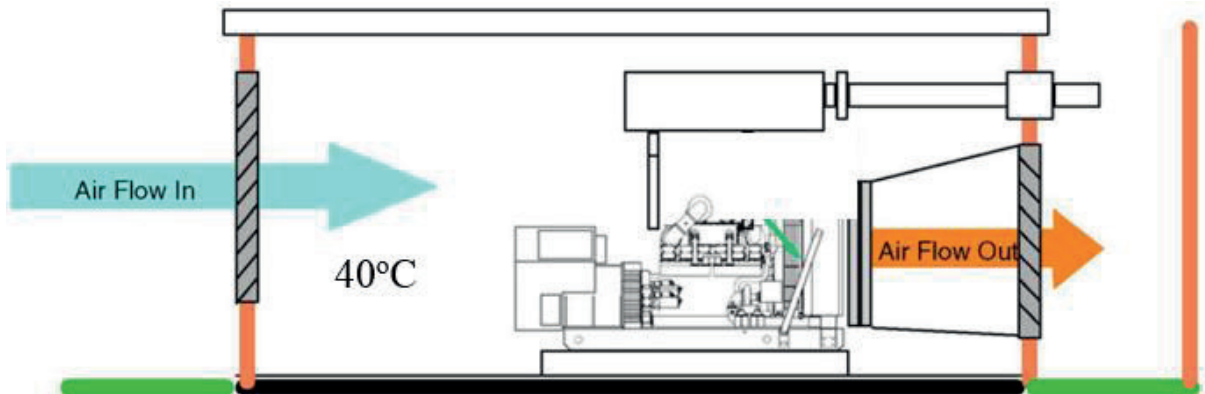

An example of a Generating Set cooling system design.

Ambient Temperature

Ambient temperature can be defined as the temperature of the surrounding air at a particular location. The internationally accepted standard value for industrial use alternators is 40°C.

The ambient temperature measured should be, in the case of an air-cooled machine such as an AvK or STAMFORD alternator, the air inlet air temperature. This may be higher than the surrounding air ambient temperature, due to the heat generated by the prime mover within the confined space of an engine house.

It is essential that the total actual temperature does not exceed the limits set by the Nameplate rating and ambient temperature identified. In some cases, especially marine machines, or for special rating cases, ambient temperatures higher than 40°C, may be specified and allowed for.

An industrial alternator operating in an ambient temperature greater than 40°C, must be de-rated to ensure that total actual temperature does not exceed the specified maximum.

The converse of this is also true; that by reducing temperature a greater output can be obtained from an alternator for the same actual temperature. This is permitted in most standards down to an ambient of 30°C.

Airflow Through the Alternator

As a standard, industrial alternators are designed for use in a maximum ambient temperature of 40°C, and altitude no higher than 1000 meters above sea level. (Air density affects cooling capability of the air – the higher the altitude, the less dense the air is, so less dense air has less cooling capability.)

Where ambient temperatures in excess of 40°C and altitudes above 1000 meters exist, these environmental operating conditions can be tolerated with reduced ratings. Refer to AGN 012 for further information.

The internal air flow is moved by a fan fixed on the machine shaft which is designed to create a pressure drop which in turn cools the alternator rotor and stator windings. The air inlet is located at the non-drive-end of the alternator while the air outlet is located at the drive-end of the alternator as show in the following illustration. Cooling air flows into the alternator through the air inlet at 40°C, cools the windings as it passes through the air gap (air path) and exit through the air outlet at about 70°C.

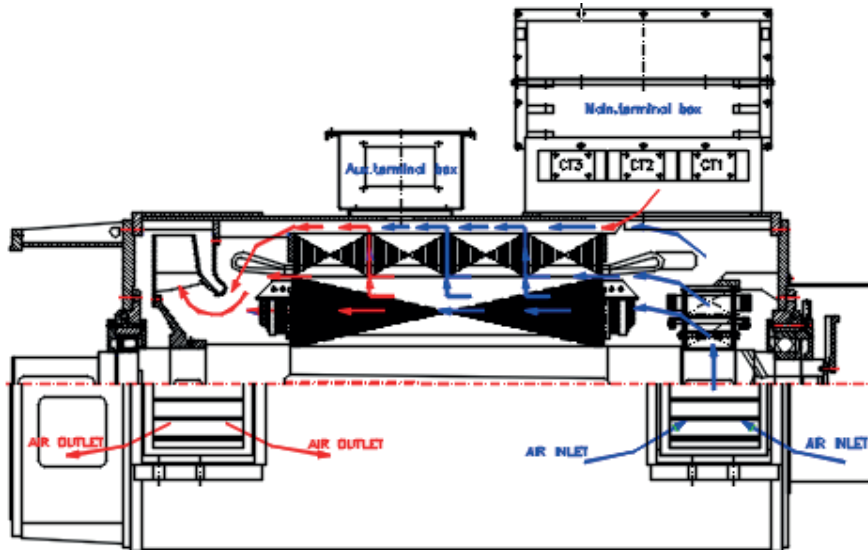

Example of the air-cooled alternator

Airflow requirements

If the generating set is installed in a building or enclosure, efficient cooling will depend on maintaining the condition of the cooling fan and air filters. There shall be no recirculating air in the generating set room to maintain the ambient temperature entering the room. If the operating environment differs from the values shown on the alternator nameplate, the rated output must be adjusted.

Alternator Air Filters

There are two types of Air Inlet Filter used on AvK and STAMFORD alternators. The type of filter design will be selected for specific environmental conditions, based on the customers identified operating conditions, sized to meet those declared conditions, and specified on the original alternator order confirmation. The two types are:

- Dry Dust Filter
- Moisture Filter

Both types of filters are manufactured by companies specialising in air filtration systems and each type of filter kit is a proprietary package from that company's standard range of appropriate products.

Environmental Conditions

When considering a proposed operational site with a contaminated atmosphere, careful consideration must be given to the design and operational functionality of the generating set housing, with special attention to air inlet and air outlet apertures. The next area of concern must be the internal airflow management system in conjunction with the type of contamination that will inevitably enter the generating set housing. Finally, the type of supplementary filter required at point of entry to the alternator, the engine and its cooling system.

The decision-making process regarding the need to consider an abnormal site and associated contaminated atmosphere must be a controlled function within the generating set manufacturer's commercial operation, where direct contact exists with the end user, their needs and required duty for any proposed generating set to identify the following points for sizing consideration

Requirements, i.e.

1. the type of contamination, particulate size
2. the medium of contamination, (carrier: air, moisture, water spray, etc)
3. The chemical composition (Acid/neutral/Alkaline)
4. The expected level of contamination (concentration of contamination verses carrier volume / density)

It is very important that the generating set supplier and installer are fully aware of the risk they place on the generator installation and equipment, to prevent operational problems occurring related to site conditions.

Air inlet filters are constructed into a specially fitted filter framework at the factory. Each filter assembly is designed specifically for a particular alternator frame size and should be fitted at the factory during alternator manufacture.

It is strongly recommended that all alternators fitted with air inlet filters are specified to be factory fitted with stator winding temperature detection devices, or differential pressure switches, thereby providing an automatic control system that can be employed to ensure that blocked air filters are detected before a winding overheats, with the risk of burn-out occurring.

Remember that maintenance of Air filters is vital to ensuring an adequate volume and temperature of ambient cooling air is supplied to the alternator.

Also remember that seasons change, and the regime of inspection and clean / replacement may also change, depending on the prevailing operational conditions.

As a rule of thumb, at commissioning, it is always wise to monitor air filters, so that it is possible to track alternator changing operational conditions, over time, and then confirm filter change / cleaning, when a tip up in alternator RTD temperatures or greater than 5 to 7°C, or an increase to 30 to 40% blocked condition is reached on the differential pressure switch.

IP Codes







IEC 60034-5:2000 describes the system for classifying the degrees of protection provided by the enclosures of rotating electrical machines such as motors and alternators. The majority of AvK and STAMFORD alternators are air-cooled, IC01 designed products with the air being drawn through the alternator by an internal fan, which is fitted to the Drive End (DE) of the alternator shaft.

The cooling airflow enters the alternator via the Non-Drive End (NDE), with the hot air being expelled at the DE.

Each of the openings associated with the cooling-air path must be fitted with a screen and, on occasion, an additional louver to comply with the relevant EU Directives for ac generators (alternators); primarily 2006/42/EC Machinery Directive. The chosen design of screen and louver will provide different levels of protection against the ingress of solid objects, plus the harmful ingress of liquids.

The degree of enclosure protection provided is indicated by the International Protection or 'IP' Code where the code typically includes two numbers. The first number is associated with the degree protection for persons, or limiting the size of solid objects that can enter the machine. The second number is associated with liquid ingress protection, water being the most likely liquid that the alternator may be exposed to.

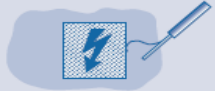
The following tables provide definition of the numbers and additional letters that make up the IP code:

FIRST NUMERAL			
IP	Requirements	Example	Meaning protection of persons against access to hazardous parts with:
0	no protection		no protection provided
1	full penetration of 50.0mm diameter sphere not allowed and shall have adequate clearance from hazardous parts. Contact with hazardous parts not permitted		back of hand
2	full penetration of 12.5mm diameter sphere not allowed. The jointed test finger shall have adequate clearance from hazardous parts		finger
3	the access probe of 2.5mm diameter shall not penetrate		tool
4	the access probe of 1.0mm diameter shall not penetrate		wire
5	limited ingress of dust permitted (no harmful deposit, refer to standard)		wire
6	totally protected against ingress of dust		wire

IP Code First Numeral Indication (Particles)

SECOND NUMERAL			ADDITIONAL LETTER (Optional)		
IP	Requirements	Example	IP	Requirements	Example
0	no protection				
1	protected against vertically falling drops of water.				
2	protected against vertically falling drops of water with enclosure tilted 15° from the vertical.				
3	protected against sprays to 60° from the vertical.				
4	protected against water splashed from all directions.				
5	protected against low pressure jets of water from all directions.				
6	protected against strong jets of water				
7	protected against the effects of immersion between 15.0 cm and 1.0 m				
8	protected against longer periods of immersion under pressure				

ADDITIONAL LETTER (Optional)		
IP	Requirements	Example
A	For use with first numerals 0 penetration of 50.0mm diameter sphere up to guard face must not contact hazardous parts.	
B	For use with first numerals 0 & 1 test finger penetration to a maximum of 80.0mm must not contact hazardous parts	
C	for use with first numerals 0, 1 & 2 wire of 2.5mm diameter x 100.0mm long must not contact hazardous parts when spherical stop face is partially entered	
D	For use with first numerals 0, 1, 2 & 3 wire of 1.0mm diameter x 100.0mm long must not contact hazardous parts when spherical stop face is partially entered	

Limited penetration allowed with X1, X2, X3, X4, X5 and all four additional letters. Refer to standard.

IP Code Second Numeral Indication (Moisture)

A typical alternator intended for use in an industrial application has an IP code number of 23 (IP 23). The '2' indicates that an object bigger than 12.5mm diameter, for example a finger, cannot enter the alternator and touch anything either moving or electrically live. The '3' indicates that the alternator's ventilation openings are designed to provide protection from falling liquids, for example rain water, which may be blown by the wind towards the alternator at some 600 from the vertical.

IP Codes on STAMFORD Alternators

All STAMFORD alternators have a standard build with enclosure protection rated at IP23.

Where IP protection is fitted from original specified supply, the IP covers will have been allowed for in terms of thermal impact to the alternator performance. It is normal during sizing, to allow an allowance of around 5% rating reduction, to manage the additional difficulties of air flowing through IP23 covers at each opening.

It is possible for larger airborne objects such as discarded work cloths, paper, cardboard, or other substances to be sucked into the IP23 air inlet covers.

If this occurs, and is left without removing the contamination, the alternator may see some additional cooling air starvation, and as a result, see an increased thermal condition, which will increase winding operational temperatures, and accelerate thermal stress, reducing operational life.

Take care to complete regular maintenance checks to ensure that IP covers are clear of debris, undamaged and remain in a good fitted condition.

Environmental Operating Conditions

There are technical considerations that must be initiated when using an alternator for applications where the operational conditions are challenging.

Challenging Operating Temperatures

Winding Operating Temperatures:

- All low voltage alternators manufactured by STAMFORD | AvK have an insulation system based on Class H materials for a total temperature of 180 °C.
- Once in service, the life expectancy of any wound component will be dependent upon complex factors, with the operating temperature of that wound assembly being a principal factor, because as the operating temperatures increase, the following parameters are exponentially reduced. (as previously discussed in the Operational Conditions section above)

Electrical Insulation systems evaluation data, such as completed for UL certification, suggests that if the wound component is operated at 180°C for some 20,000 hours, the system will incur a measurable level of 'thermal degradation', which in laboratory terms is described as a reduction to a 'half-life' condition. This does not mean that the insulation system will fail at 40,000 hours, it is simply a laboratory 'measure' of the now degraded condition of the insulation materials due to 'thermal degradation'.

For comparison, UL advises that if a Class H insulation system is operated at a Class F (155°C) rating, then the half-life increases to 120,000 hours and if operated at a Class B (120°C) rating, then the half-life increases to 640,000 hours.

It must be pointed out that many factors affect the life expectancy of a wound assembly, and whilst the operating temperature may well be the principal factor, other environmental and operational factors come into play when considering impact to design operational life:

- Air borne contamination, which if allowed to come into contact with the surface of the windings thereby promoting surface tracking, or initiating chemical erosion.
- Transiently Imposed vibration during transportation, or continuous vibration from the prime-mover, which subsequently promote relative movement between phase to phase or phase to earth insulation barriers.
- Voltage spikes or current surges generated by the connected load that challenge the dielectric strength of the insulation system, which under extremely unstable conditions (deviations from rated voltage and current conditions) the stresses may initiate a rupture of the insulation barrier.

The following table and notes are offered as a reference guide for the operating temperature limits of a typical low voltage industrial alternator. The above recommendations should be considered against the following tabled values, which are the Cummins Generator Technologies recommended typical operating thermal limits, as measured by stator winding embedded RTD's.

Class F	Alarm	145°C	Class H	Alarm	170°C
Class F	Trip	165°C	Class H	Trip	190°C

The above values indicate the advised thermal limits for a typical industrial application where the alternator is operating at fixed voltage level, totally under the control of its own AVR and is supplying a connected load that does not exceed the rated nameplate values. The Nameplate values being, voltage, current, power factor; and is a balanced three phase load with non-distorting linear load characteristics. Also, the on-site conditions do not allow the temperature at the air inlet to the alternator to exceed 40°C.

For further information or clarification on these Application Guidance Notes, please contact STAMFORD / AvK Application Engineering

Email: applications@cummins.com

stamford-avk@cummins.com

www.stamford-avk.com



Copyright 2024, Cummins Generator Technologies Ltd. All rights reserved.
Cummins and the Cummins logo are registered trade marks of Cummins Inc.
STAMFORD and AvK are registered trademarks of Cummins Generator Technologies Ltd.

STAMFORD | AvK TM

POWERING TOMORROW, TOGETHER