

STAMFORD®

MX322 AUTOMATIC VOLTAGE REGULATOR (AVR) TECHNICAL DATASHEET

GENERAL DESCRIPTION

MX322 is a three phase sensed Automatic Voltage Regulator and forms part of the excitation system for a brush-less alternator. Excitation power is derived from a three-phase permanent magnet generator (PMG), to isolate the AVR control circuits from the effects of non-linear loads and to reduce radio frequency interference on the alternator terminals. Sustained alternator short circuit current is another feature of the PMG system.

The AVR senses the voltage in the main alternator winding and controls the excitation to maintain the alternator output voltage within the specified limits, compensating for load, speed, temperature and power factor of the alternator. Three phase RMS sensing is employed for superior voltage regulation.

A unique circuit has been implemented that allows the use of traditional, rugged and proven phase controlled thyristor power stage, coupled with the additional ability to provide full wave output power to the excitation system during short circuit events. Current limiting may be included to allow control over the amount of sustained short circuit current.

Adjustable Soft start circuitry is included to provide a smooth controlled buildup of alternator output voltage.

A frequency measuring circuit continually monitors the shaft speed of the alternator and provides under-speed protection of the excitation system by reducing the alternator output voltage proportionally with speed below a pre-settable threshold. A further enhancement of this feature is an adjustable volt per Hertz slope and voltage recovery time, to improve the response of turbo charged engines.

Maximum excitation is limited to a safe period by internal shutdown of the AVR output device. This condition remains latched until the alternator has stopped.

The AVR includes an over-voltage protection feature with internal shutdown of the AVR output device, plus the ability to trip an optional excitation circuit breaker if required.

Provision is made for the connection of a remote voltage trimmer, allowing the user fine control of the alternator's output. An analogue input is provided allowing connection to a STAMFORD Power Factor controller or other external device with compatible output. The AVR has the facility for droop CT connection, to allow parallel running with other similarly equipped alternators.

TECHNICAL SPECIFICATION

SENSING INPUT

Voltage 170-264V ac max, 2 or 3 phase
Frequency 50-60 Hz nominal

POWER INPUT (PMG)

Voltage 170-220V ac max, 3phase,3wire
Current 3A/phase
Frequency 100-120 Hz nominal

OUTPUT

Voltage max 180V dc
Current continuous 4.2A (see note 1)
Intermittent 9A for 10 secs.
Resistance 15 ohms minimum

REGULATION

+/- 0.5% RMS with 4% engine governing (see note 2)

THERMAL DRIFT

0.02% per deg. C change in AVR ambient (note 3)

SOFT START RAMP TIME

0.4 - 4 seconds

TYPICAL SYSTEM RESPONSE

AVR response 10 ms
Filed current to 90% 80 ms
Machine Volts to 97% 300 ms

EXTERNAL VOLTAGE ADJUSTMENT

+/-10% with 5 k ohm 1 watt trimmer (see note 4)

UNDER FREQUENCY PROTECTION

Set point 95% Hz (see note 5)
Slope 100-300% down to 30 Hz
Max. Dwell 20% volts/S recovery

UNIT POWER DISSIPATION

18 watts maximum

ANALOGUE INPUT

Maximum input +/- 5 Vdc (see note 6)
Sensitivity 1v for 5% Alternator Volts (adjustable)
Input resistance 1k ohm

QUADRATURE DROOP INPUT

Burden 10 ohms
Max. sensitivity: 0.22 A for 5% droop 0PF
Max. input: 0.33 A

CURRENT LIMIT INPUT

Burden 10 ohms
Sensitivity range: 0.5 – 1A

OVER VOLTAGE DETECTOR INPUT

Set point: 300V
Time delay: 1 Sec (fixed)
CB trip coil volts: 10-30 vdc
CB trip coil resistance: 20-60 ohms

OVER EXCITATION PROTECTION

Set point 75 V dc
Time delay 8-15 seconds (fixed)

ENVIRONMENTAL

Vibration 20-100 Hz 50mm/sec
100Hz – 2kHz 3.3g
Operating temperature -40 to +70°C
Relative Humidity 0-70°C 95% (see note 7)
Storage temperature -55 to +80°C

NOTES

1. Derate linearly from 4.2A at 50°C to 3.2A at 70°C
2. The stated voltage regulation may not be maintained in the presence of certain transmitted radio signals. Any change in regulation will fall within the limits in Criteria B of BS.EN.61000-6-2:2005.
3. After 10 minutes.
4. Alternator de-rate may apply. Check with factory.
5. Factory set, semi-sealed, jumper selectable.
6. Any device connected to the analogue input must be fully floating (galvanically isolated from ground), with an insulation strength of 500V ac.
7. Non condensing.

DESIGN DETAILS

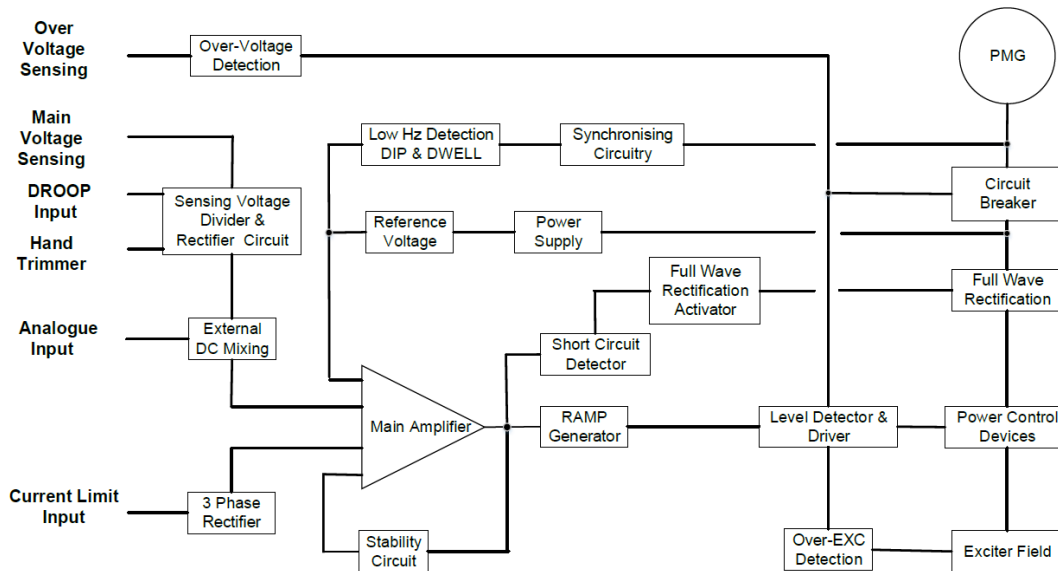

The main functions of the AVR are:

Potential Divider and Rectifier takes a proportion of the alternator output voltage and attenuates it. The potential divider is adjustable by the AVR Volts potentiometer and external hand trimmer (when fitted). The output from the droop CT is also added to this signal. A rectifier converts the a.c. input signal into a d.c. signal representing alternator voltage.

The DC Mixer adds the Analogue input signal the alternator voltage signal.

The 3 Phase Rectifier converts the output of the current limit CT's into a dc signal representing alternator current.

The Amplifier (Amp) compares the alternator voltage or current signals to the Reference Voltage and amplifies the difference (error) to provide a controlling signal for the power devices. The Ramp Alternator and Level Detector and Driver infinitely control the conduction period of the Power Control Devices and hence provides the excitation system with the required power to maintain the alternator voltage within specified limits.

The Stability Circuit provides adjustable negative ac feedback to ensure good steady state and transient performance of the control system.

The Power Supply provides the required voltages for the AVR circuitry.

The Low Hz Detector measures the period of each electrical cycle and causes the reference voltage to be reduced approximately linearly with speed below a presettable threshold. The Dip and Dwell circuits provide adjustments for greater voltage roll off and recovery time. A Light Emitting Diode gives indication of underspeed running.

The Synchronising circuit is used to keep the Ramp Alternator and Low Hz Detector locked to the Permanent Magnet Generator waveform period.

Power Control Devices vary the amount of exciter field current in response to the error signal produced by the Amplifier.

The Circuit Breaker provides circuit isolation of the control system in the event of an over excitation or over voltage condition.

The Over Excitation Detector continuously monitors the exciter field voltage and turns off the power device if this rises above the reference level for greater than the stated time period. An external signal is also provided to trip the Circuit Breaker

The Over Voltage Detector continuously monitors the alternator stator voltage and turns off the power device if this rises above the reference level, for greater than the stated time period. An external signal is also provided to trip the Circuit Breaker

The Short-Circuit Detector continuously monitors the output of the main error amplifier of the AVR. The output of this error amplifier is proportional to the difference between the AVR's internal reference point and the sensed alternator output voltage.

Once a short circuit has been detected the Short-Circuit Activator provides a full wave output to the field. A three-phase bridge consisting of six power devices forms the AVR power rectification stage, its output feeds power to the excitation field, the level of which is adjusted by the main control thyristor.

A three-phase bridge consisting of six power devices forms the AVR power Full Wave Rectification stage, its output feeds power to the excitation field, the level of which is adjusted by the main control thyristor. In the condition of short circuit activated, remaining two power devices turns on and acts as a full wave rectification to provide more volts and / or current to the exciter field.

FITTING AND OPERATING (Refer to alternator wiring diagram for connection details)

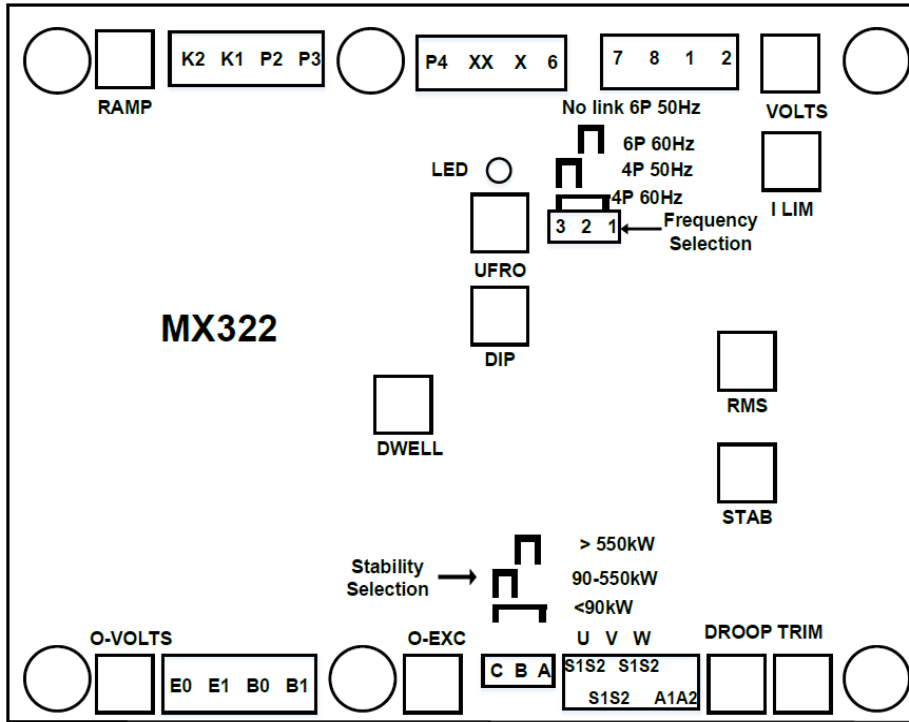

SUMMARY OF AVR CONTROLS		
CONTROL	FUNCTION	DIRECTION
VOLTS	To adjust alternator output voltage	Clockwise increases output voltage
STAB	To prevent voltage hunting	Clockwise increase the damping effect
UFRO	To set the UFRO knee-point	Clockwise reduces the knee-point frequency
DROOP	To set the alternator DROOP to 5% at 0PF	Clockwise increases the DROOP
TRIM	To optimize analogue input sensitivity	Clockwise increases the gain or sensitivity
O-EXC	To set the over-excitation trip level	Clockwise increases the trip level
DIP	To set the Hz related voltage DIP	Clockwise increases the DIP
DWELL	To set the Hz related recovery time	Clockwise increases the recovery time
I LIMIT	To set the stator current limit	Clockwise increases the current limit
O-VOLTS	To set the over-voltage trip level	Clockwise increases the trip level
RAMP	To set the no load voltage ramp up time	Clockwise increases the voltage ramp time

ADJUSTMENT OF AVR CONTROLS

VOLTAGE ADJUSTMENT

The alternator output voltage is set at the factory, but can be altered by careful adjustment of the VOLTS control on the AVR board, or by the external hand trimmer if fitted. Terminals 1 and 2 on the AVR will be fitted with a shorting link if no hand trimmer is required.

WARNING! Do not increase the voltage above the rated alternator voltage. If in doubt, refer to the rating plate mounted on the alternator case.

WARNING! Do not ground any of the hand trimmer terminals, as these could be above earth potential. Failure to observe this could cause equipment damage.

If a replacement AVR has been fitted or re-setting of the VOLTS adjustment is required, proceed as follows:

1. Before running alternator, turn the VOLTS control fully anti-clockwise.
2. Turn remote volts trimmer (if fitted) to midway position.
3. Turn STABILITY control to midway position.
4. Connect a suitable voltmeter (0-300V ac) across line to neutral of the alternator.
5. Start alternator set, and run on no load at nominal frequency e.g. 50-53Hz or 60-63Hz.
6. If the red Light Emitting Diode (LED) is illuminated, refer to the Under Frequency Roll Off (UFRO) adjustment. *Continued.....*

7. Carefully turn VOLTS control clockwise until rated voltage is reached.
8. If instability is present at rated voltage, refer to stability adjustment, then re-adjust voltage if necessary.
9. Voltage adjustment is now completed.

STABILITY ADJUSTMENT

The AVR includes a stability or damping circuit to provide good steady state and transient performance of the alternator.

A jumper link selector is provided to optimise the response of the stability circuit to various size alternators. The link should be positioned as shown in the diagram according to the kW rating of the alternator.

The correct setting of the Stability adjustment can be found by running the alternator at no load and slowly turning the stability control anti-clockwise until the alternator voltage starts to become unstable. The optimum or critically damped position is slightly clockwise from this point (i.e. where the machine volts are stable but close to the unstable region).

UNDER FREQUENCY ROLL OFF (UFRO) ADJUSTMENT

The AVR incorporates an underspeed protection circuit which gives a volts/Hz characteristic when the alternator speed falls below a presettable threshold known as the "knee" point. The red Light Emitting Diode (LED) gives indication that the UFRO circuit is operating.

The UFRO adjustment is preset and sealed and only requires the selection of 50 or 60Hz and 4 pole or 6 pole, using the jumper link as shown in the diagram.

For optimum setting, the LED should illuminate as the frequency falls just below nominal, i.e. 47Hz on a 50Hz system or 57Hz on a 60Hz system.

DROOP ADJUSTMENT

Alternators intended for parallel operation are fitted with a quadrature droop C.T. which provides a power factor dependent signal for the AVR. The C.T. is connected to S1, S2 on the AVR, (see alternator wiring diagram for details). The DROOP adjustment is normally preset in the works to give 5% voltage droop at full load zero power factor.

Clockwise increases the amount of C.T. signal injected into the AVR and increases the droop with lagging power factor ($\cos \phi$). With the control fully anti-clockwise there is no droop.

TRIM ADJUSTMENT

An analogue input (A1 A2) is provided to connect to the STAMFORD Power Factor Controller or other devices. It is designed to accept dc signals up to +/- 5 volts.

WARNING! Any devices connected to this input must be fully floating and galvanically isolated from ground, with an insulation capability of 500V ac. Failure to observe this could result in equipment damage.

TRIM ADJUSTMENT *continued*

The dc signal applied to this input adds to the AVR sensing circuit. A1 is connected to the AVR 0 volts. Positive on A2 increases excitation. Negative on A2 decreases excitation. The TRIM control allows the user to adjust the sensitivity of the input. With TRIM fully anti-clockwise the externally applied signal has no effect. Clockwise it has maximum effect.

Normal setting is fully clockwise when used with a STAMFORD Power Factor Controller.

OVER EXCITATION (EXC) ADJUSTMENT

This adjustment is set and sealed in the works and should not be tampered with. An over excitation condition is indicated by the illumination of the red LED which also indicates under-speed running and over-volts.

The alternator must be stopped to reset an over-excitation trip.

DIP ADJUSTMENT

This feature is mostly used when the alternator is coupled to turbo charged engines with limited block load acceptance. The feature works by increasing the V/Hz slope to give greater voltage roll off in proportion to speed.

With the DIP control fully anti-clockwise, the alternator voltage will follow the normal V/Hz line as the speed falls below nominal. Turning the DIP control clockwise provides greater voltage roll off aiding engine recovery.

DWELL

This feature is mostly used when the alternator is coupled to turbo charged engines with limited block load acceptance. The feature works by introducing a delay between speed recovery and voltage recovery and allows a greater DIP setting without instability. With the DWELL control fully anti clockwise, the alternator voltage will follow the V/Hz line. Turning the DWELL control clockwise increase the delay time between speed recovery and voltage recovery.

CURRENT LIMIT (I LIMIT) ADJUSTMENT

This feature is mostly used to limit short circuit current or to provide a current limit on motor starting. To use this feature, current limit CT's of the correct ratio need to be connected to the AVR S1 S2 terminals. There is an internal time limit of 10 seconds. Consult the factory before using this feature.

OVER VOLTAGE (OVER V) ADJUSTMENT

This adjustment is set and sealed in the works and should not be tampered with. An over voltage condition is indicated by the illumination of the red LED which also indicates under-speed running and over-excitation. The alternator must be stopped to reset an over-voltage trip.

RAMP

The AVR includes a soft start or voltage ramp-up circuit to control the rate of voltage build up, when the alternator runs up to speed. This is normally pre-set and sealed to give a voltage ramp-up time of approximately 3 seconds. If required, this can be adjusted between the limits defined in the specification.

STAMFORD

Cummins Generator Technologies
Fountain Court • Lynch Wood • Peterborough • PE2 6FZ • UK
Tel: +44 (0) 1733 395300
stamford-avk.com