

REL NO	REV	DETAIL	DWN	CKD	APVD	DATE
ECO-160793	C	PRODUCTION RELEASE	PS	UKD	S. JOSHI	21 JUL 16
SEE ECO						

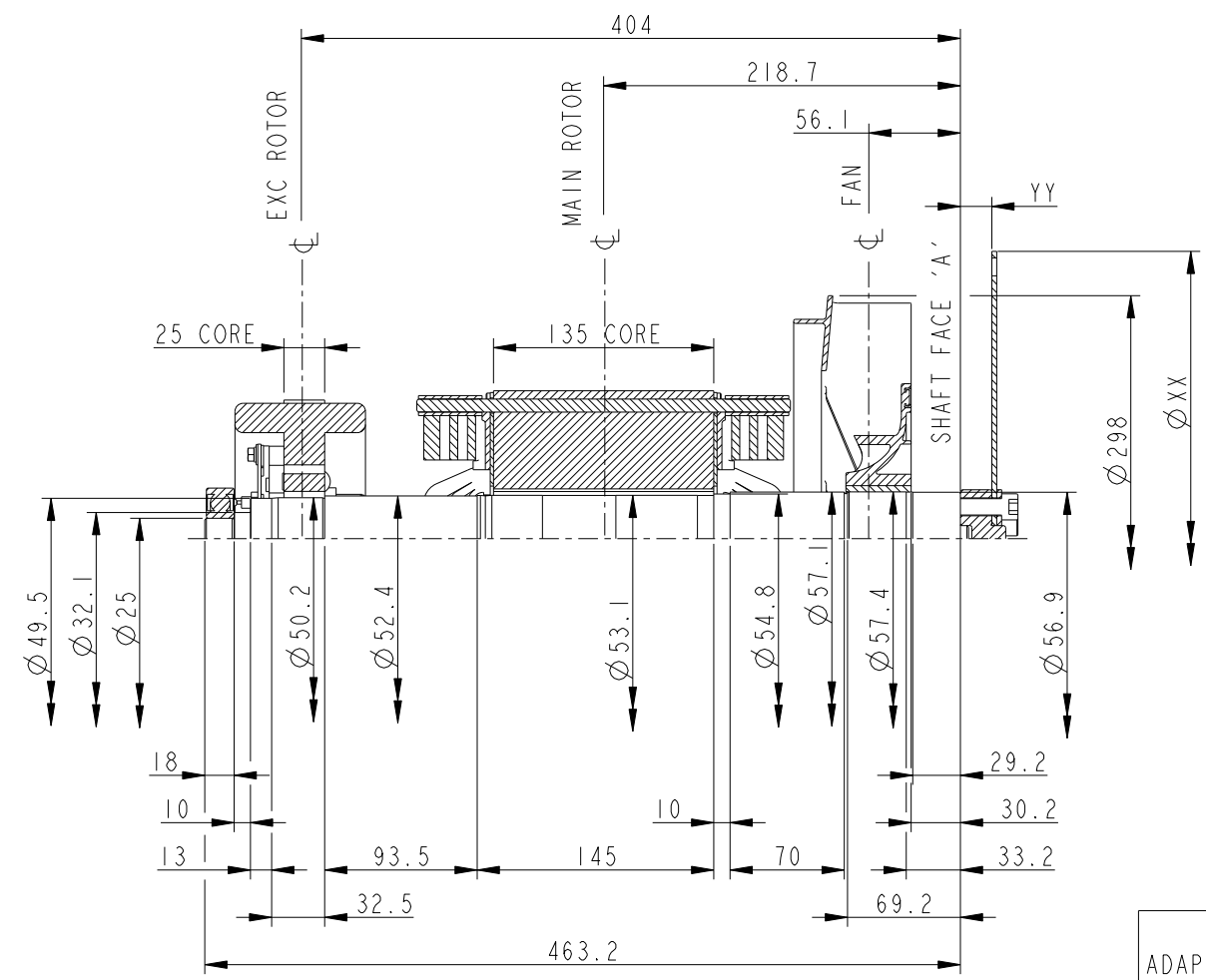

NOTES:

- SHAFT STIFFNESS:
THE STIFFNESS OF THE SHAFT BETWEEN THE MAIN ROTOR CORE CL AND THE SHAFT FACE 'A' IS 3.4884×10^6 kgcm/radian (STIFFENING EFFECT OF MAIN ROTOR CORE IS NOT INCLUDED IN THIS FIGURE)
- SHAFT MATERIAL:
STEEL - C40E TO BSEN 10083-2 2006
MAXIMUM RECOMMENDED VIBRATORY STRESS LEVEL IN THE SHAFT IS 34.47×10^6 N/m² FOR SPEED RANGE OF 0.95 TO 1.1 X NOMINAL SPEED AND 68.94×10^6 N/m² FOR RUN THROUGH CONDITIONS, FOR INDUSTRIAL MACHINES.
- CUMMINS GENERATOR TECHNOLOGIES LTD SHOULD BE NOTIFIED OF ANY ROTORS NOT COMPLYING WITH THESE RULES.
- CUMMINS GENERATOR TECHNOLOGIES LTD BALANCE ROTORS TO COMPLY WITH INTERNATIONAL STD BS ISO 1940 PARTS 1 AND 2. BALANCE GRADE 2.5
- FOR UNBALANCED MAGNETIC PULL (U.M.P.) REFER BACK TO THE FACTORY

ADAPTOR SAE No.	COUPLING SAE No.	COUPLING DIMENSIONS		MASS OF DISCS (kg) (1 X 3mm THICK)	MASS OF DISCS (kg) (4 X 1.2mm THICK)	MASS OF SHAFT SPACER (kg)	MASS OF PRESSURE PLATE (kg)	TOTAL MASS OF COUPLING ASSEMBLY (kg)	COUPLING STIFFNESS (kgcm/rad)	COUPLING DISC WR ² (kgm ²)
		Ø XX mm	YY mm							
4/5	6 1/2	215.8	9.88	0.835	-	0.175	0.048	1.058	12.00×10^6	0.0049
4/5	7 1/2	241.2	9.88	1.047	-	0.175	0.048	1.270	11.90×10^6	0.0077
3/4	10	314.2	33.47	1.790	-	0.592	0.048	2.431	11.71×10^6	0.0221
3	11 1/2	352.3	19.27	2.260	-	0.341	0.048	2.650	11.66×10^6	0.0351
3	11 1/2	352.3	17.47	-	3.616	0.309	0.048	3.973	18.70×10^6	0.0562

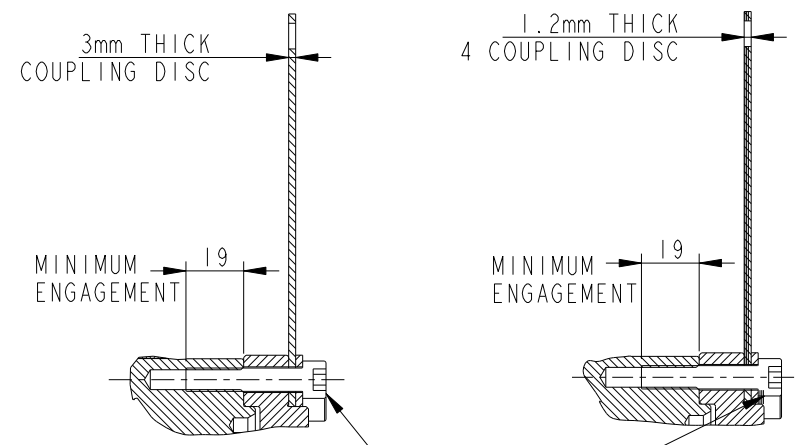

SECTION A-A SCALE 1:2

6 EQUI-SPACED SOCKET HEAD SCREW M10 X 1.5 PITCH ON 39 PCD TORQUE 73 Nm

TO CONVERT	TO	DIVIDE BY
kg	lb	0.453592
kg m ²	lb ft ²	0.04214
kgcm/rad	lbin/rad	1.1521246
N/m ²	lbf/in ²	6894.76

COMPONENT	Wt Kg	WR ² Kgm ²
FAN	0.797	0.0069
SHAFT	7.835	0.0028
MAIN ROTOR	23.342	0.0992
EXCITER ROTOR	4.56	0.0180
TOTAL	36.534	0.1269

UNLESS OTHERWISE SPECIFIED, ALL DIMENSIONS ARE IN MILLIMETERS

DO NOT SCALE PRINT

ANG TOL: ± 0.5° SCALE: 1:4

SIM TO -

DWN S. PRABHA
CKD U. DAGWALE
APVD S. JOSHI
DATE 05JUN15

FOR INTERPRETATION OF DIMENSIONING AND TOLERANCING, SEE ASME Y14.5M-1994

CUMMINS GENERATOR TECHNOLOGIES

DRAWING, TORSIONAL SOL2-G1 4P

SITE CODE

FORTUNA PUN

A052Z776

SHEET 1 REV C