

4

3

2

1

D



Part Number: A074D058

Change Notice	CN00173867	Alternates	
Manufacturer Part (MEP)	No	Usage	Production Only
Release Phase Code	Production (P)	Drawing Specification	Number: DS47133822
External Regulations	No External Regulation		Revision: C

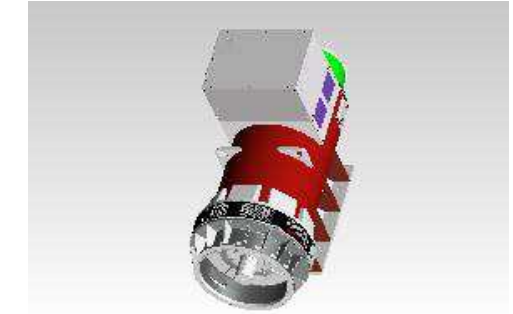

3D image provided when available for visual reference only.

C

Drawing Revision Information

Description of Change(s) Note: Change information is provided for reference only and does not supersede the drawing's primary content.
MINOR AMENDMENT
ADMINISTRATIVE CHANGE(S) TO PART ATTRIBUTES, BILL OF MATERIAL, OR ASSOCIATED SPECIFICATIONS.

Drawing Authorization

Drafter	Nivas Raj	Date	03MAR2025
Checker	Sneha Pundlikrao Bondlewad	Date	04MAR2025
Approver	NO APPROVAL REQUIRED	Date	

B

A

Cummins Data Classification: **Cummins Confidential** This document (and the information shown thereon) is **Confidential and Proprietary** and shall not be disclosed to others in hard copy or electronic form, reproduced by any means, or used for any purpose without written consent of Cummins Inc.

Part Number: **A074D058** Part Revision: **C**
 Part Name: **ARRANGEMENT,GENERATOR GENERAL**
 Drawing Category: **Outline** State: **Released** Sheet 2 of 2

4

3

2

1