

DL15-12579

ISSUE
A

IF IN DOUBT-ASK
DO NOT SCALE

FIRST W.O.

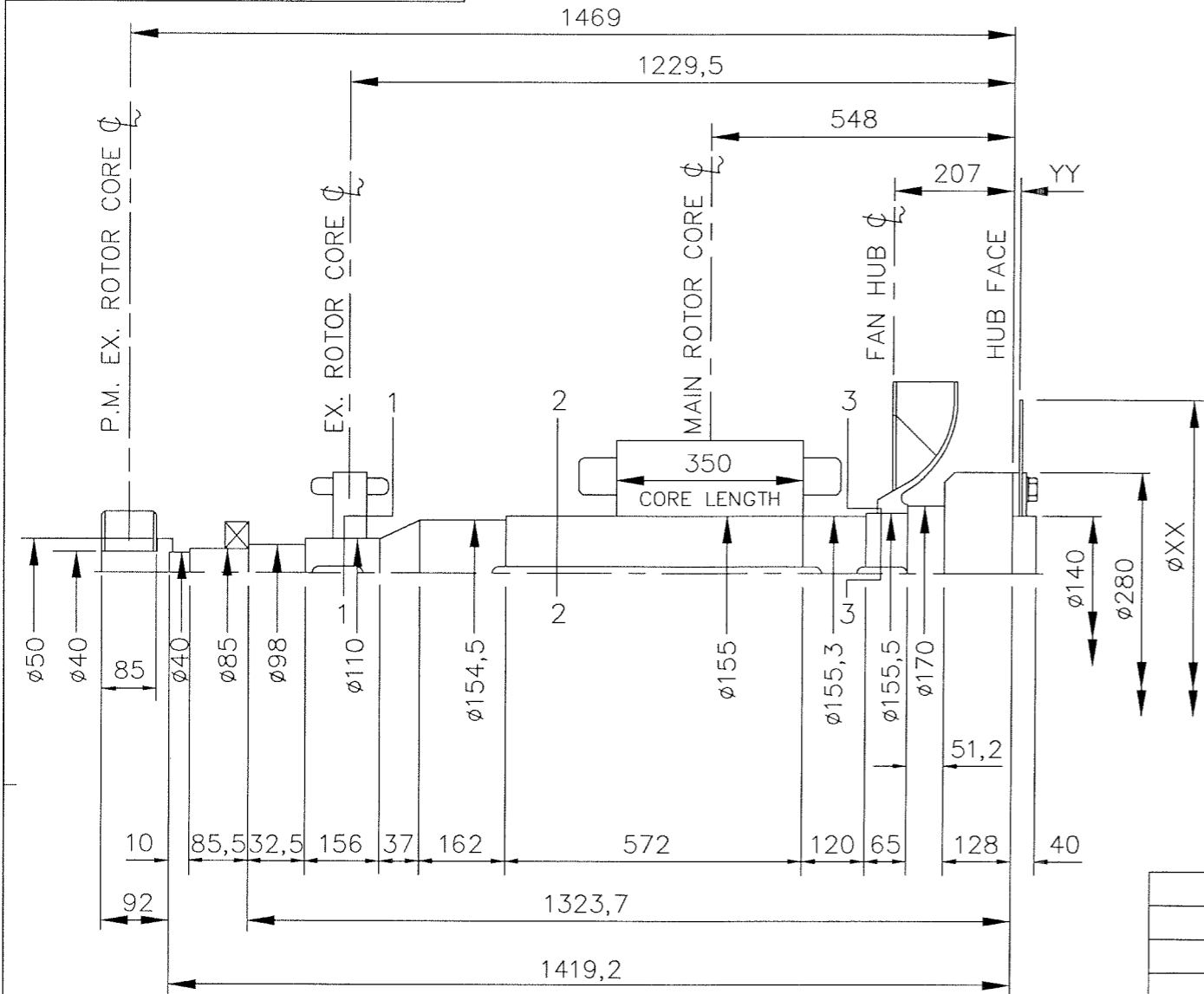

NOTES!

SHAFT STIFFNESS:-

THE STIFFNESS OF THE SHAFT BETWEEN THE MAIN ROTOR CORE ϕ AND THE COUPLING HUB FACE IS $111,35 \times 10^6$ kgcm/radian (STIFFENING EFFECT OF MAIN ROTOR CORE IS NOT INCLUDED IN THIS FIGURE)

SHAFT MATERIAL:-

STEEL - 080M40 TO BS970 PART 1 (APPROVED BY MARINE AUTHORITIES WHEN APPROPRIATE).

MAXIMUM RECOMMENDED VIBRATORY STRESS LEVEL IN THE SHAFT IS $34,47 \times 10^6$ N/m² FOR A SPEED RANGE OF 0,95 TO 1,1 x NOMINAL SPEED, AND $68,94 \times 10^6$ N/m² FOR RUN THROUGH CONDITIONS, FOR INDUSTRIAL MACHINES. FOR MARINE AUTHORITIES, THEIR APPROPRIATE RULES WILL APPLY.

NEWAGE INTERNATIONAL LTD. SHOULD BE NOTIFIED OF ANY ROTORS NOT COMPLYING WITH THESE RULES.

NEWAGE INTERNATIONAL LTD. BALANCE ROTORS TO COMPLY WITH INTERNATIONAL STD. I.S.O. 1940 GRADE 2,5 AND B.S. 6861 PART 1 GRADE 2,5 .

FOR UNBALANCED MAGNETIC PULL (U.M.P.) FORCES REFER TO GENERATOR MANUAL.

SECTION THRO' SHAFT
END AND COUPLING
SCREWS OR BOLTS

MINIMUM 43
ENGAGEMENT

6 DISCS 7,2mm
1,2mm EACH

12 EQUI-SPACED
SCREWS OR BOLTS
M24 x 3 PITCH ON
230 P.C.D.

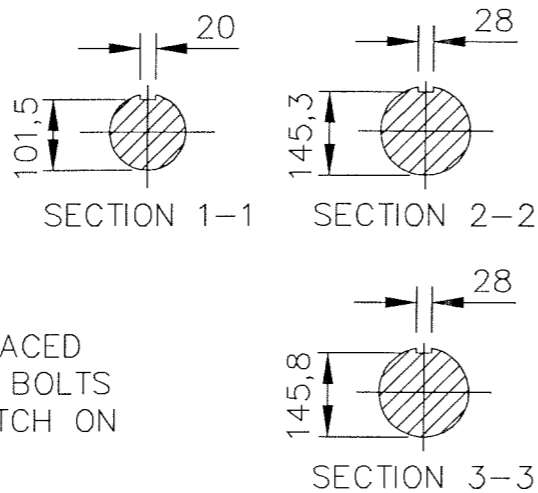

COMPONENT	Wt kg	WR ² kgm ²	COUPLING SAE No	COUPLING DIMEN's		COUPLING ASSEMBLY WEIGHT kg	COUPLING STIFFNESS 6-PLATES kgcm/rad	COUPLING DISC WR ² kg m ²
				XX	YY			
EX. ROTOR	51,600	0,8590						
MAIN ROTOR	481,500	16,8411						
FAN	16,100	0,6762						
SHAFT	191,923	0,5514	14	467	25	25	$1395,6 \times 10^6$	0,265
HUB	37,098	0,4823	16	518	16	24,3	$1296,5 \times 10^6$	0,403
P.M. EX. ROTOR	6,970	0,0190	18	572	16	24,40	$1211,3 \times 10^6$	0,535
P.M. STUB SHAFT	0,929	0,0003	21	673	00	24,25	$1140,7 \times 10^6$	1,053
			17 3/4	451	18,2	24,75	$1534,8 \times 10^6$	0,230
			24	733	00	28,00	$1064,8 \times 10^6$	1,602
TOTAL	786,120	19,4293	24 Spec	733	28,5	38,30	$1064,8 \times 10^6$	1,602

CONVERSION FACTORS		
TO CONVERT	TO	DIVIDE BY
kg	lb	0,453592
kg m ²	lb ft ²	0,04214
kgcm/rad	lbin/rad	1,1521246
N/m ²	lbf/in ²	6894,76

CERTIFIED PRINT
(ONLY IF SIGNED)
BY
DATE
DRAWN S.M.C. 13.07.00
CH'D S.M.C. 17.7.00
APP'D [Signature] 17/7/00

HC636 1H
MOMENTS OF INERTIA
AND SHAFT DETAILS
NEWAGE INTERNATIONAL LTD
STAMFORD ENGLAND

SCALE FIRST W.O.
NTS
SHEET 1:10
UNIT OF MEASUREMENT
MILLIMETRES (mm)
DL15-12579
ISSUE
A

4/3000/2	A	S.M.C.	13.07.00	ORIGINAL ISSUE
MOD'N	ISSUE	DRAWN	DATE	ALTERATION