

STAMFORD®

MX322 Automatic Voltage Regulator (AVR)
INSTRUCTION MANUAL

Table of Contents

1. DESCRIPTION.....	1
2. SPECIFICATION.....	3
3. CONTROLS.....	5

-

This page is intentionally blank.

1 Description

MX322 is a three phase sensed Automatic Voltage Regulator (AVR) and forms part of the excitation system for a brush-less alternator. Excitation power is derived from a three-phase permanent magnet generator (PMG), to isolate the AVR control circuits from the effects of non-linear loads and to reduce radio frequency interference on the alternator terminals.

Sustained alternator short circuit current is an additional feature of the PMG system.

1.1 Separately-Excited AVR Controlled Alternators

A separately-excited AVR receives power from a separate permanent magnet generator (PMG), mounted on the main alternator shaft. The AVR controls the alternator output voltage by automatic adjustment of the exciter stator field strength. The AVR excitation remains at full capability when sudden loads are applied to the alternator, giving superior motor starting, short circuit and EMC performance.

1.2 Permanent Magnet Generator (PMG) excited - AVR controlled alternators

 **WARNING**

Strong Magnetic Field

The strong magnetic field from a permanent magnet generator (PMG) or excitation boost system (EBS), can cause serious injury or death by interference with implanted medical devices.

To prevent injury, do not work near a PMG or EBS if you have an implanted medical device.

The AVR provides closed loop control by sensing the alternator output voltage at the main stator windings and adjusting the exciter stator field strength. Voltage induced in the exciter rotor, rectified by the rotating diodes, magnetises the rotating main field which induces voltage in the main stator windings. A separately-excited AVR is independently powered from a separate permanent magnet generator (PMG), mounted on the main alternator rotor shaft. Voltage is induced in the stator of the PMG by a rotor of permanent magnets.

TABLE 1. PMG EXCITED AVR

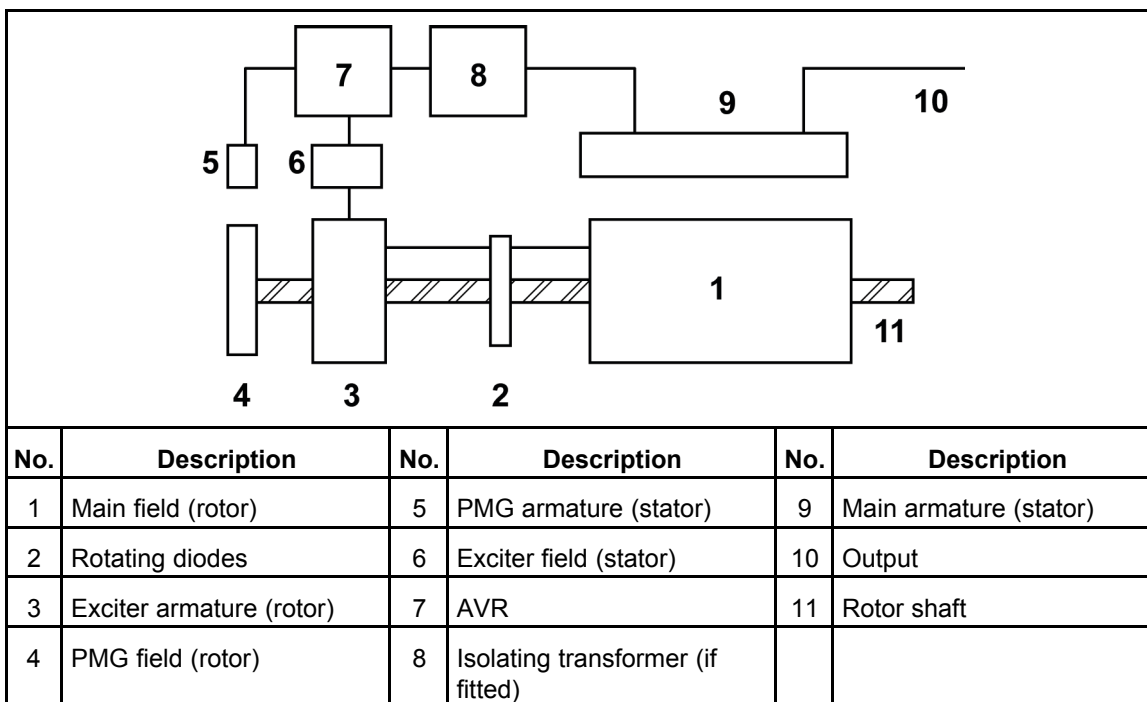

2 Specification

2.1 MX322 Technical Specification

- **Sensing Input**
 - Voltage: 170 VAC to 264 VAC maximum, 2 or 3 phase
 - Frequency: 50 Hz to 60 Hz nominal
- **Power Input**
 - Voltage: 170 VAC to 220 VAC maximum, 3 phase, 3 wire
 - Current: 3 A per phase
 - Frequency: 100 Hz to 120 Hz nominal
- **Power Output**
 - Voltage: maximum 180 VDC
 - Current:
 - continuous 4.2 A¹
 - transient 9 A for 10 seconds
 - Resistance: 15 Ω minimum
- **Regulation**
 - +/- 0.5% RMS²
- **Thermal Drift**
 - 0.02% per 1 °C change in AVR ambient temperature³
- **Soft Start Ramp Time**
 - 0.4 s to 4 s
- **Typical Response**
 - AVR response in 10 ms
 - Field current to 90% in 80 ms
 - Machine Volts to 97% in 300 ms
- **External Voltage Adjustment**
 - +/-10% with 5 k Ω , 1W trimmer⁴
- **Under-Frequency Protection**
 - Set point 95% Hz⁵
 - Slope 100% to 300% down to 30 Hz

¹ De-rate linearly from 4.2 A at 50 °C to 3.2 A at 70 °C

² With 4% engine governing. The stated voltage regulation may not be maintained in the presence of certain transmitted radio signals. Any change in regulation will fall within the limits in Criteria B of BS EN 61000-6-2: 2001

³ After 10 minutes

⁴ Alternator de-rate may apply. Check with factory.

⁵ Factory set, semi-sealed, jumper selectable

-
- Maximum dwell 20% V/s recovery
 - **Unit Power Dissipation**
 - 18W maximum
 - **Analogue Input**
 - Maximum input: +/- 5 VDC⁶
 - Sensitivity: 1V for 5% Alternator Volts (adjustable)
 - Input resistance 1 k Ω
 - **Quadrature Droop Input**
 - 10 Ω burden
 - Maximum sensitivity: 0.22 A for 5% droop, zero power factor
 - Maximum input: 0.33 A
 - **Current Limit Input**
 - 10 Ω burden
 - Sensitivity range 0.5 A to 1 A
 - **Over-Voltage Detection**
 - Set point: 300 VDC.
 - Time delay: 1 s (fixed)
 - Circuit breaker trip coil voltage: 10 VDC to 30 VDC
 - Circuit breaker trip coil resistance: 20 Ω to 60 Ω
 - **Over-Excitation Protection**
 - Set point: 75 VDC.
 - Time delay: 8 s to 15 s (fixed)
 - **Environmental**
 - Vibration:
 - 20 Hz to 100 Hz: 50 mm/sec
 - 100 Hz to 2 kHz: 3.3 g
 - Operating temperature: -40 °C to +70 °C
 - Relative Humidity 0 °C to 70 °C: 95%⁷
 - Storage temperature: -55 °C to +80 °C

⁶ Any device connected to the analogue input must be fully floating (galvanically isolated from ground), with an insulation strength of 500 VAC

⁷ Non-condensing.

3 Controls

⚠ DANGER

Live Electrical Conductors
Live electrical conductors can cause serious injury or death by electric shock and burns. To prevent injury and before removing covers over electrical conductors, isolate the generator set from all energy sources, remove stored energy and use lock out/tag out safety procedures.

⚠ DANGER

Live Electrical Conductors
Live electrical conductors at output, AVR and AVR accessory terminals, and AVR heat sink can cause serious injury or death by electric shock and burns. To prevent injury, take suitable precautions to prevent contact with live conductors including personal protective equipment, insulation, barriers and insulated tools.

NOTICE

Refer to alternator wiring daigram for connection details.

3.1 MX322 Configuration

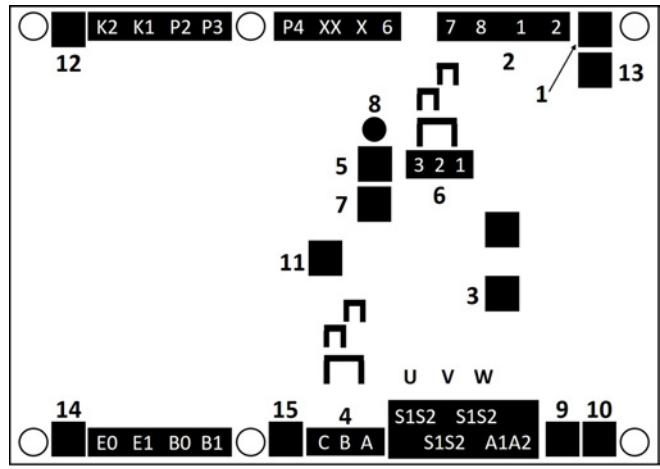

FIGURE 1. MX322 AVR CONTROLS

Ref.	Control	Function	Turn potentiometer CLOCKWISE to
1	AVR [VOLTS]	Adjust alternator output voltage	increase voltage
2	Link : Hand trimmer 1-2 : No trimmer None : Trimmer fitted	Adjust alternator output voltage	increase voltage
3	AVR [STAB]	Adjust stability to prevent voltage hunting	increase damping effect

Ref.	Control	Function	Turn potentiometer CLOCKWISE to
4	Link : Power A-B : > 550 kW B-C : 90-550 kW A-C : < 90 kW	Select stability response for alternator size	N/A
5	AVR [UFRO]	Adjust under-frequency roll-off knee point	reduce UFRO frequency
6	Link : Frequency None : 6 pole 50 Hz 1-2 : 6 pole 60 Hz 2-3 : 4 pole 50 Hz 1-3 : 4 pole 60 Hz	Select alternator frequency for UFRO	N/A
7	AVR [DIP]	Adjust under-frequency voltage dip rate	increase rate
8	Light Emitting Diode	LED lights in UFRO, O/VOLTS or O/EXC condition	N/A
9	AVR [DROOP]	Adjust alternator droop to 5% at zero power factor	increase droop
10	AVR [TRIM]	Adjust analog input sensitivity	increase sensitivity
11	AVR [DWELL]	Adjust voltage recovery	increase recovery time
12	AVR [RAMP]	Adjust soft start voltage ramp	increase ramp time
13	AVR [I LIMIT]	Adjust current limit protection	increase current limit
14	AVR [OVER V]	Adjust over-voltage protection	increase trip voltage
15	AVR [EXC]	Adjust over-excitation protection	increase trip excitation voltage

3.2 Initial AVR Setup

NOTICE

The AVR must be setup only by authorised, trained service engineers. Do not exceed the designed safe operating voltage, shown on the alternator rating plate.

The AVR controls are set at the factory for initial running tests. Check that the AVR settings are compatible with your required output. Do not adjust controls that have been sealed. To set up a replacement AVR, follow these steps:

1. Stop and isolate the generator set.
2. Install and connect the AVR.
3. Turn the **AVR [VOLTS]** volts control [Section 3.3 on page 7](#) fully counter-clockwise.
4. Turn the hand trimmer (if fitted) to 50%, the midway position.
5. Turn the **AVR [STAB]** stability control [Section 3.4 on page 8](#) to 50%, the midway position.
6. Connect a suitable voltmeter (0 to 300 VAC range) between one output phase and neutral.
7. Start the generator set with no load.
8. Adjust speed to nominal frequency (50 to 53 Hz or 60 to 63 Hz).

9. If the LDE is lit, adjust the **AVR [UFRO]** control [Section 3.5 on page 8](#).
10. Carefully turn **AVR [VOLTS]** control clockwise until the voltmeter shows rated voltage.
11. If voltage is unstable, adjust the **AVR [STAB]** stability control.
12. Re-adjust the **AVR [VOLTS]** control, as needed.

3.3 Adjust the AVR [VOLTS] Voltage Control

NOTICE

Do not exceed the designed safe operating voltage, shown on the alternator rating plate.

NOTICE

Hand trimmer terminals may be above earth potential. Do not ground any of the hand trimmer terminals. Grounding hand trimmer terminals could cause equipment damage.

To set the output voltage AVR [VOLTS] control on the AVR:

1. Check the alternator nameplate to confirm the designed safe operating voltage.
2. Set the **AVR [VOLTS]** control to 0%, the fully counter-clockwise position.

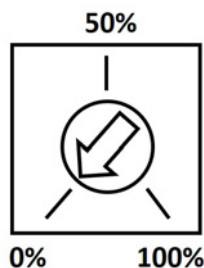

3. Check that the remote hand trimmer is fitted or terminals 1 and 2 are linked.

NOTICE

If a remote hand trimmer is connected, set it to 50%, the midway position.

4. Turn the **AVR [STAB]** control to 50%, the midway position.
5. Start the alternator and set at the correct operating speed.
6. If the red Light Emitting Diode (LED) is illuminated, refer to the Under Frequency Roll Off **AVR [UFRO]** adjustment.
7. Adjust the **AVR [VOLTS]** control slowly clockwise to increase the output voltage.

NOTICE

If the voltage is unstable set the AVR stability before proceeding [Section 3.4 on page 8](#).

8. Adjust the output voltage to the desired nominal value (VAC).
9. If instability is present at rated voltage, refer to the **AVR [STAB]** adjustment, then adjust **AVR [VOLTS]** again, if necessary.
10. If a remote hand trimmer is connected, check its operation.

NOTICE

0% to 100% rotation corresponds to 90% to 110% VAC

The **AVR [VOLTS]** control is now set.

3.4 Adjust the AVR [STAB] Stability Control

1. Check the nameplate to confirm the power rating of the alternator.
2. Check that the jumper link or rotary switch selection (depending on AVR type) matches the alternator power rating for optimal stability response.
3. Set the **AVR [STAB]** control to approximately 75% position.

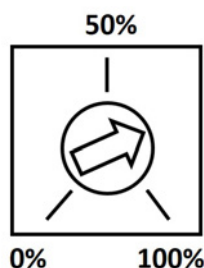

4. Start the alternator and set at the correct operating speed.
5. Verify that the alternator voltage is within safe limits.

NOTICE

If the voltage is unstable go immediately to step 5.

6. Adjust the **AVR [STAB]** control slowly counter-clockwise until the output voltage becomes unstable.
7. Adjust the **AVR [STAB]** control slowly clockwise until the voltage is stable.
8. Adjust the **AVR [STAB]** control a further 5% clockwise.

NOTICE

Readjust the voltage level if necessary (see [Section 3.3 on page 7](#)).

The **AVR [STAB]** control is now set.

3.5 Adjust the AVR [UFRO] Under-Frequency Roll-Off Control

Below an adjustable frequency threshold ('knee' point), the AVR under-speed protection operates to reduce ('roll-off') the excitation voltage in proportion to alternator frequency. The AVR LED lights when UFRO operates.

1. Check the nameplate to confirm the frequency of the alternator.
2. Check that the jumper link or rotary switch selection (depending on AVR type) matches the alternator frequency.
3. Set the **AVR [UFRO]** control to 100%, the fully clockwise position.

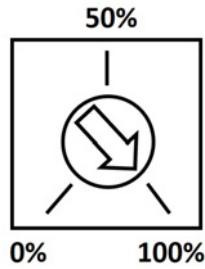

4. Start the alternator and set at the correct operating speed.
5. Verify that the alternator voltage is correct and stable.

NOTICE

If the voltage is high / low / unstable, use method [Section 3.3 on page 7](#) or [Section 3.4 on page 8](#) before proceeding.

6. Reduce the alternator speed to approximately 95% of correct operating speed. i.e. 47.5 Hz for 50 Hz operation, 57.0 Hz for 60 Hz operation.
7. Adjust the **AVR [UFRO]** control slowly counter-clockwise until the AVR LED lights.



8. Adjust the **AVR [UFRO]** control slowly clockwise until the AVR LED is just OFF.



NOTICE

Do not go past the point at which the LED is just OFF.

9. Adjust the alternator speed back to 100% nominal. The LED should be off.



The **AVR [UFRO]** control is now set.

3.6 Adjust the AVR [DIP] Dip Control

Some generator set prime movers, for example turbocharged engines, have limited capacity to tolerate sudden load increases. The rotational speed, and therefore the frequency of the alternator output, falls below the UFRO setting. The AVR reduces the excitation voltage - and hence the output power - in proportion to the frequency, to allow the prime mover to recover. The **AVR [DIP]** control adjusts the proportion.

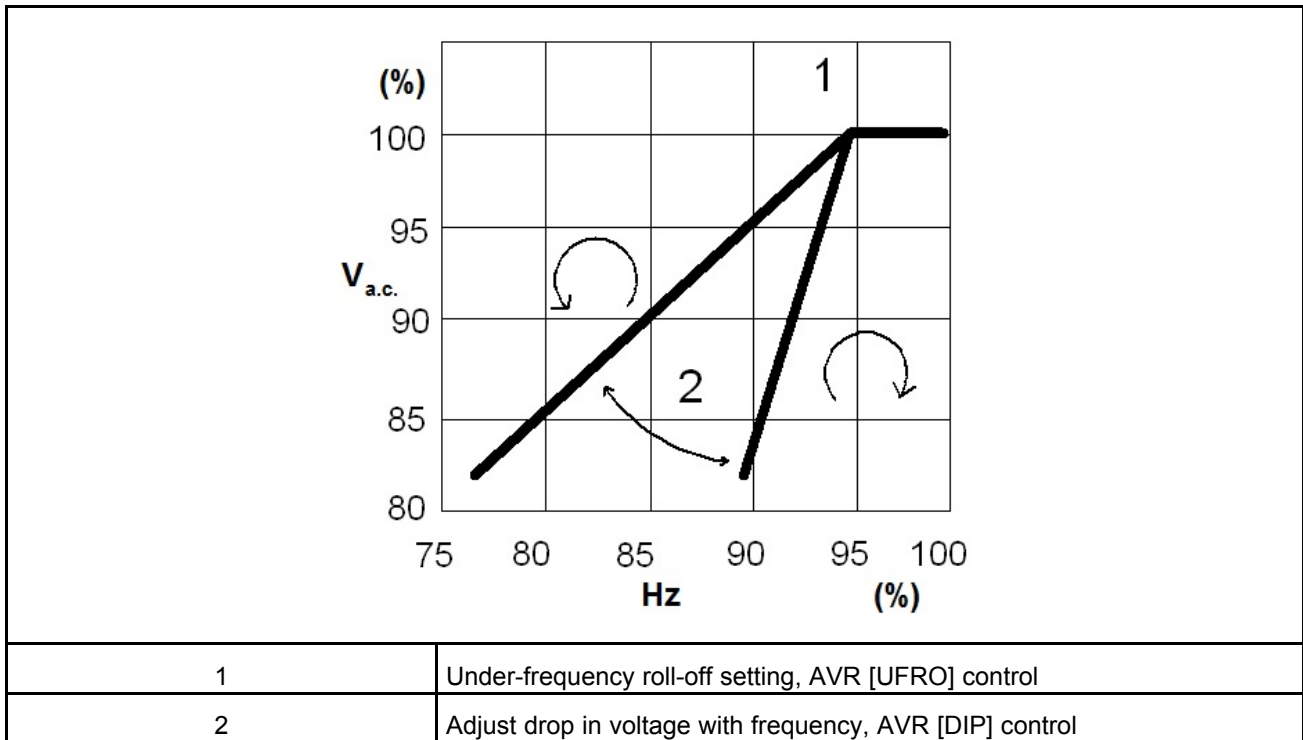

FIGURE 2. EFFECT OF AVR [DIP] CONTROL

1. For the minimum effect (1% fall in frequency gives 1% voltage drop), turn the **AVR [DIP]** control fully counter-clockwise.
2. For the maximum effect (1% fall in frequency gives 3% voltage drop), turn the **AVR [DIP]** control fully clockwise.

3.7 Adjust the AVR [DROOP] Voltage Droop Control for Parallel Operation

A correctly fitted and adjusted droop current transformer (CT) allows the alternator to share reactive current for stable parallel operation.

1. Mount the Droop CT to the correct phase lead of the main output windings of the alternator.
2. Connect the two secondary leads marked S1 and S2 from the CT to the terminals S1 and S2 of the AVR.
3. Turn the **AVR [DROOP]** control to the midway position.
4. Start the alternator(s) and set at the correct operating speed and voltage.
5. Parallel the alternator(s) according to installation rules and procedures.
6. Set the **AVR [DROOP]** control to produce the required balance between individual alternator output currents. Set the AVR droop off-load and then check the currents when the output load is applied, on-load.
7. If the individual alternator output currents rise (or fall) in an uncontrolled way, isolate and stop the alternators then check that:
 - The droop transformer is fitted to the correct phase and in the correct polarity (see the machine wiring diagrams).
 - The droop transformer secondary S1 and S2 leads are connected to the AVR terminals S1 and S2.
 - The droop transformer is the correct rating.

3.8 Adjust the AVR [TRIM] Trim Control

NOTICE

AVR analog inputs must be fully floating (galvanically isolated from ground), with an insulation strength of 500 V a.c. to avoid equipment damage.

An analog input (-5 VDC to +5 VDC) modifies the AVR excitation voltage, by adding to, or subtracting from, the sensed alternator voltage. A Stamford Power Factor Controller (PFC3) can provide such an input. The **AVR [TRIM]** control adjusts the effect.

1. Connect the analog input from the PFC3, or similar, to terminals A1 and A2 of the AVR. Terminal A1 is connected to AVR zero volts. Positive voltage connected to A2 increases AVR excitation, negative voltage connected to A2 decreases AVR excitation.
2. Turn the **AVR [TRIM]** control to the desired position. The analog signal has no effect on excitation when the **AVR [TRIM]** control is fully counter-clockwise, and maximum effect when fully clockwise.

3.9 Adjust the AVR [OVER V] Over-Voltage Control

NOTICE

The AVR [OVER V] control is set and sealed at the factory to protect the alternator from over-voltage. Incorrect AVR [OVER V] control setting could damage the alternator.

The AVR protects the alternator by removing excitation if it senses that the alternator output voltage exceeds a threshold set by the **AVR [OVER V]** control.

1. If the alternator output voltage exceeds the over-voltage setting, the red LED on the AVR turns on.
2. After a short time, the AVR removes the excitation voltage and the red LED flashes (which can also indicate an over-excitation trip or UFRO operation).
3. Stop the alternator to reset the over-voltage condition.

3.10 Adjust the AVR [DWELL] Dwell Control

Some generator set prime movers, for example turbocharged engines, have limited capacity to tolerate sudden load increases. The AVR introduces a time delay before increasing the excitation voltage after an under-frequency condition, to allow the prime mover to recover. The **AVR [DWELL]** control adjusts the proportion.

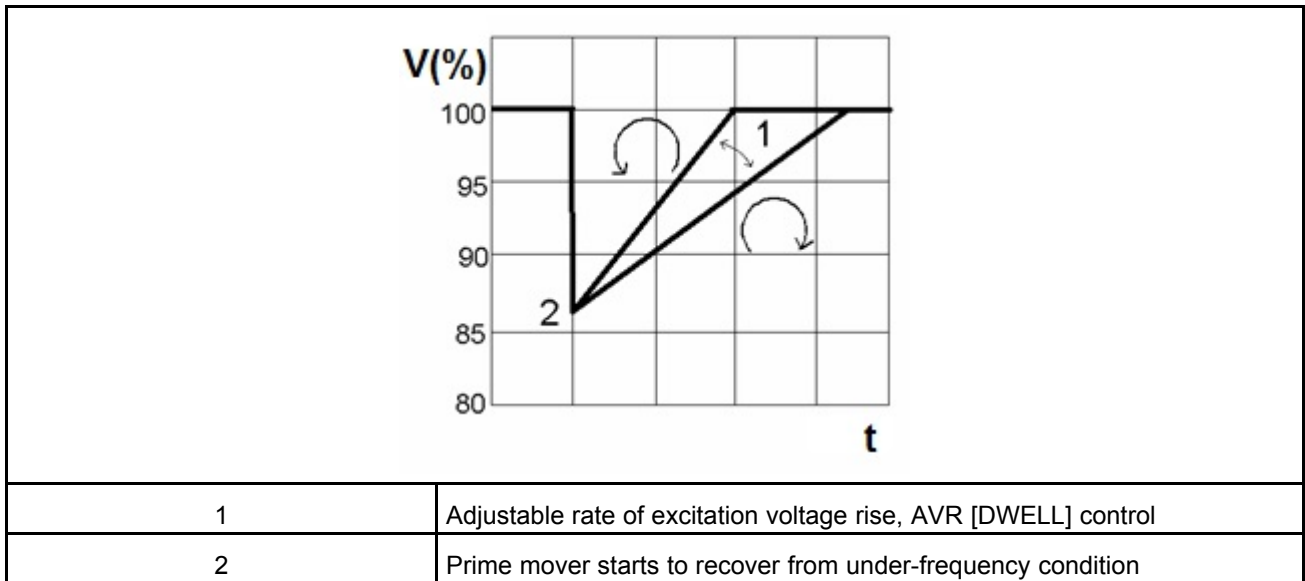

FIGURE 3. EFFECT OF AVR [DWELL] CONTROL

1. For the minimum effect (excitation voltage follows speed according to UFRO V/Hz ramp), turn the **AVR [DWELL]** control fully counter-clockwise.
2. For the maximum effect (excitation voltage lags speed increase by several seconds), turn the **AVR [DWELL]** control fully clockwise.

3.11 Adjust the AVR [RAMP] Dwell Control

The AVR includes a soft start circuit to control the rate of excitation voltage rise, as the alternator starts and runs up to speed. The **AVR [RAMP]** control adjusts the rate.

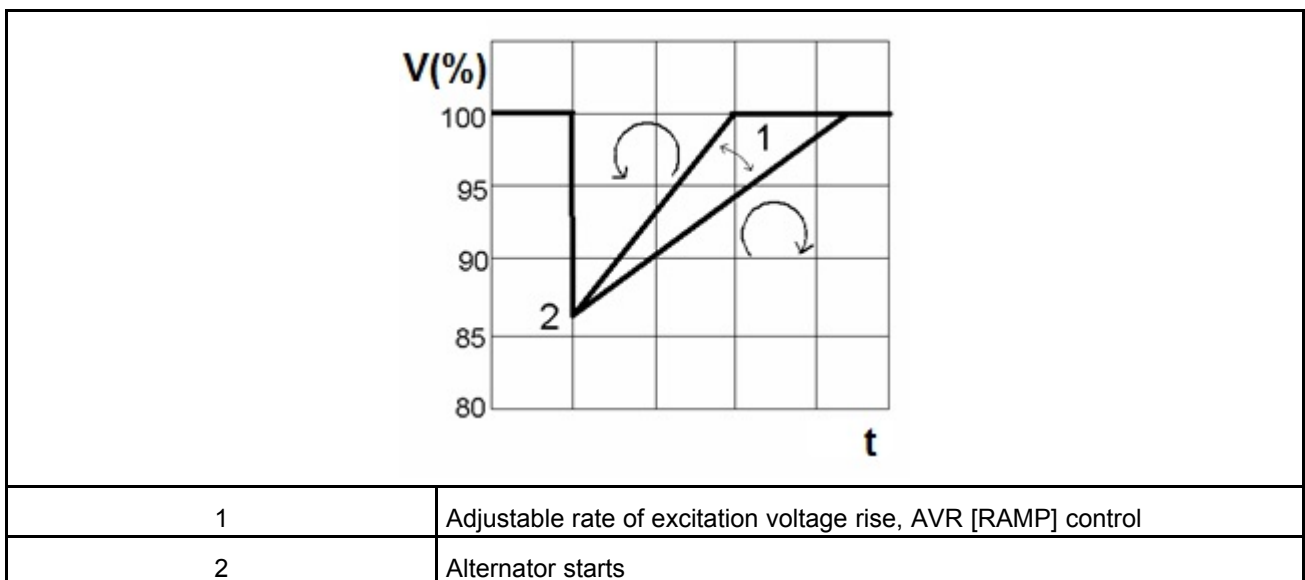

FIGURE 4. EFFECT OF AVR [RAMP] CONTROL

1. For the minimum effect (excitation voltage reaches 100% in about 0.5s), turn the **AVR [RAMP]** control fully counter-clockwise.
2. For the maximum effect (excitation voltage reaches 100% in about 4.0s), turn the **AVR [RAMP]** control fully clockwise.

3.12 Adjust the AVR [EXC] Over-Excitation Control

NOTICE

The AVR [EXC] control is set and sealed at the factory to protect the alternator from over-excitation, usually caused by overload. Incorrect AVR [EXC] control setting could damage the alternator rotor components.

The AVR protects the alternator by removing excitation if it senses that the excitation voltage exceeds a threshold set by the **AVR [EXC]** control.

1. If the excitation voltage exceeds the over-excitation trip setting, the red LED on the AVR turns on.
2. After a short time, the AVR removes the excitation voltage and the red LED flashes (which can also indicate an over-voltage trip or UFRO operation).
3. Stop the alternator to reset the over-excitation condition.

3.13 Current Limiting Transformers

Alternator main output current can be electronically limited by connecting additional current transformers to the MX322 AVR. In any situation where the output current attempts to rise above a preset threshold (set on AVR) then the AVR will reduce the terminal voltage to restore the set current level. For unbalanced loads, operation is based on the highest of the three phase currents.

-

This page is intentionally blank.



www.stamford-avk.com

Copyright 2019, Cummins Generator Technologies Ltd. All Rights Reserved
Cummins and the Cummins logo are registered trademarks of Cummins Inc.