

C OF G(mm)	WEIGHT (Kg)
886	2925

NOTES:
 1. CUSTOMER MAY CUT CABLE ENTRY HOLES AS REQUIRED IN ANY OF THE FOUR TERMINAL BOX SIDES SUBJECT TO POSITION OF AVR, TERMINALS ETC
 2. CUSTOMER MUST ENSURE THAT AIR INLET & OUTLET POSITIONS ARE NOT OBSTRUCTED

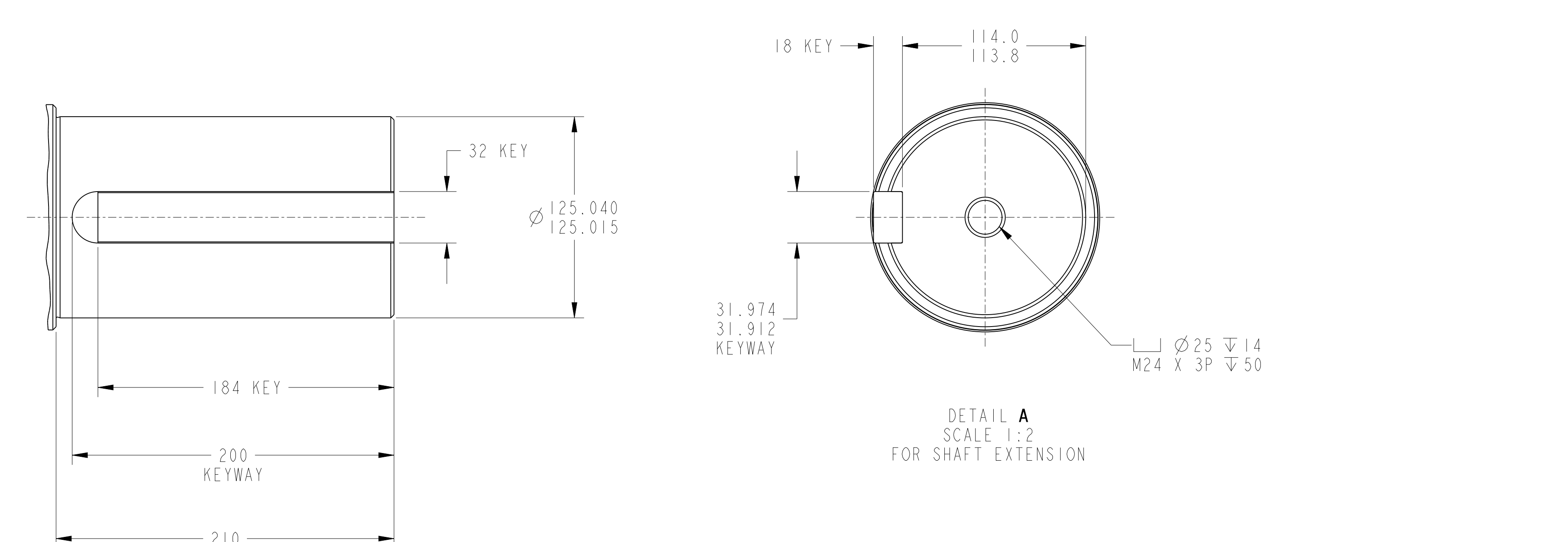
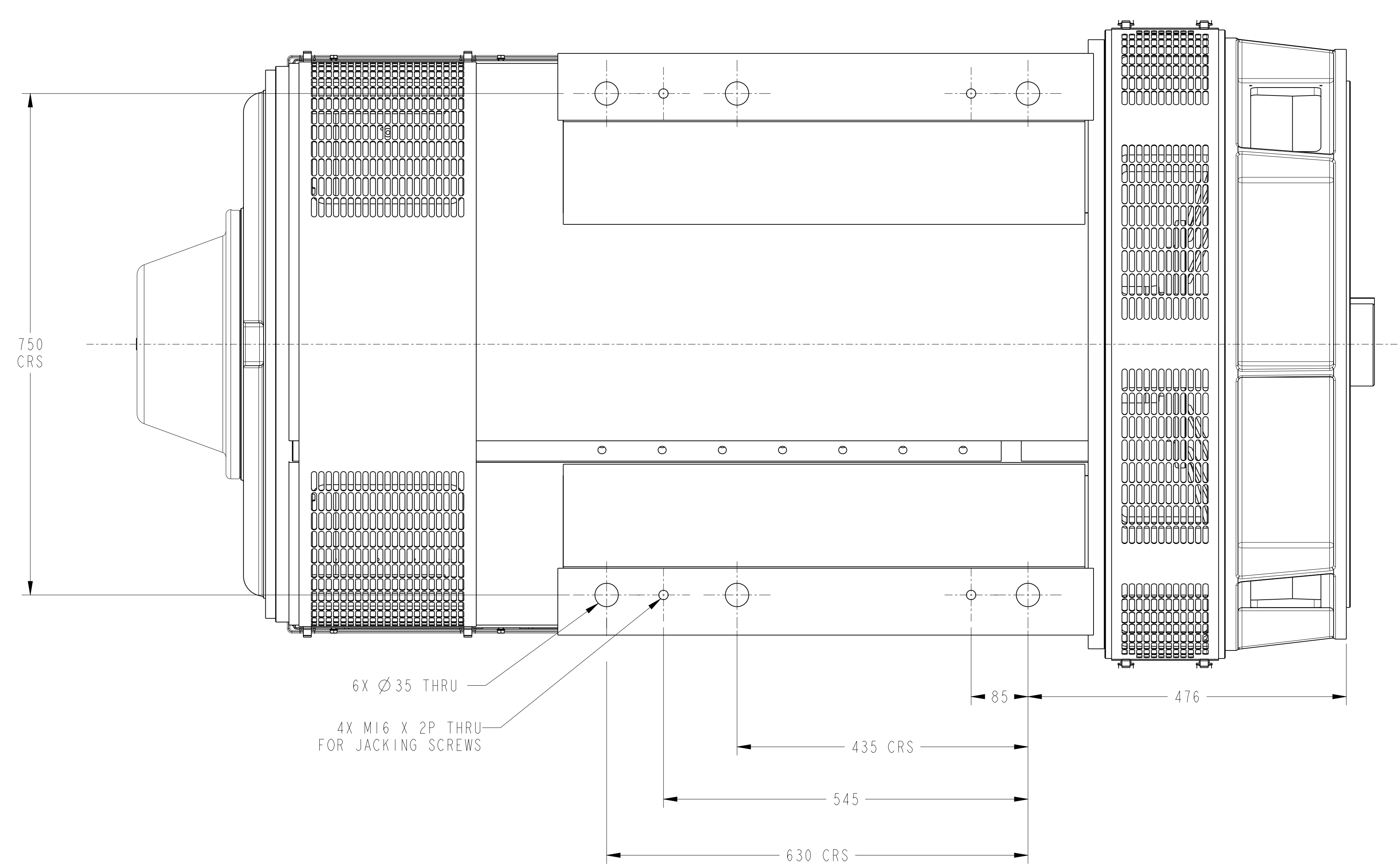
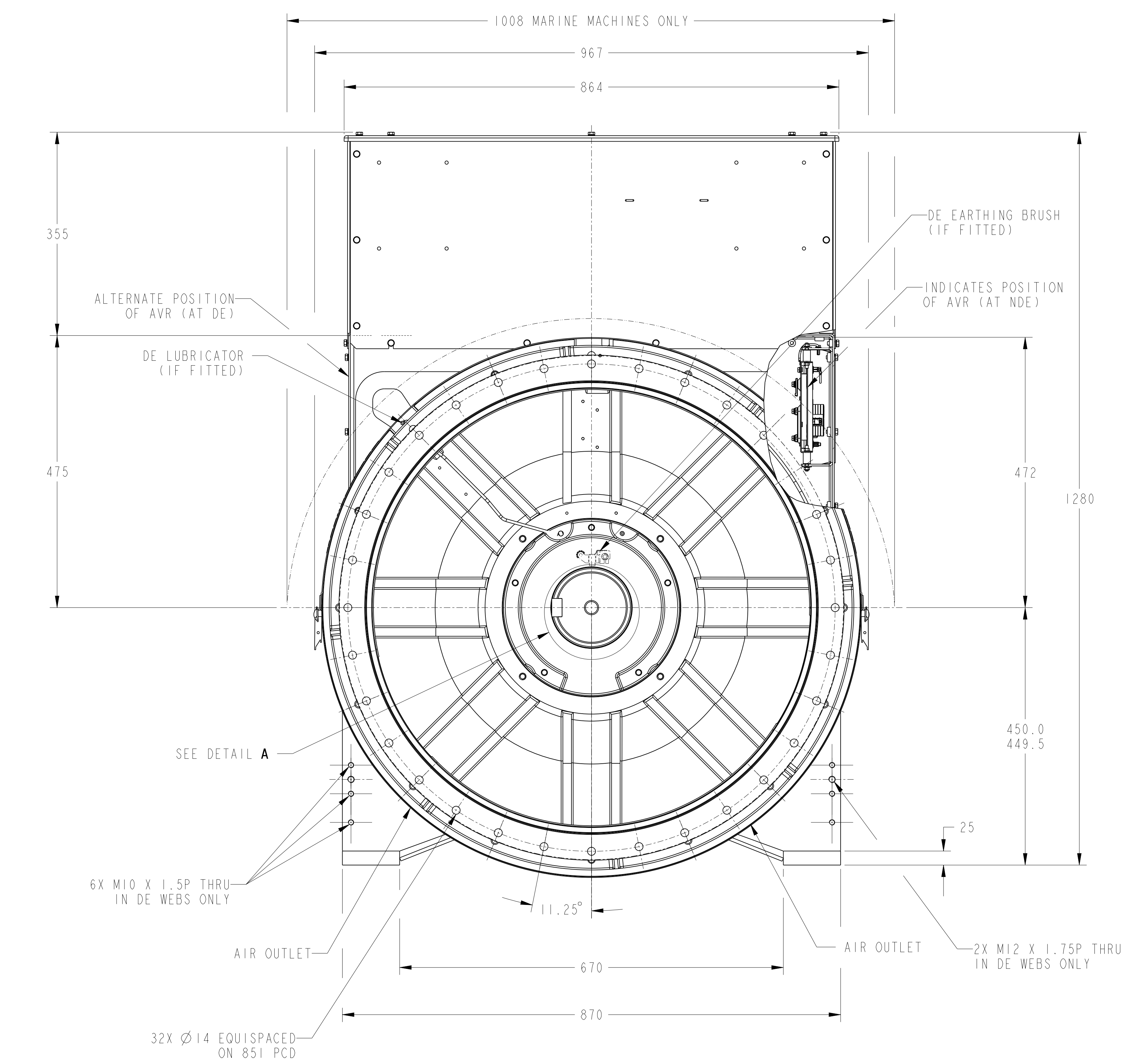
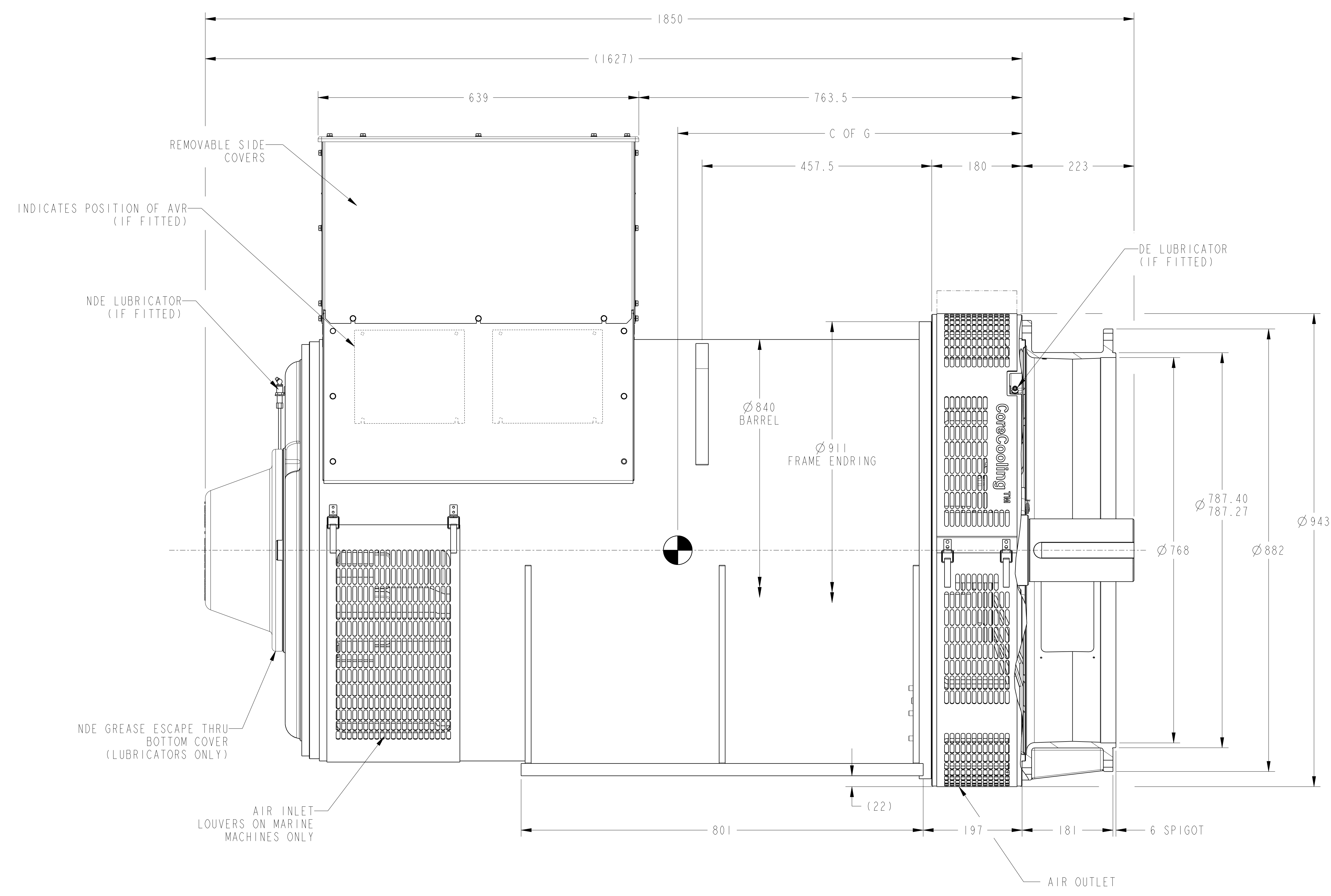

PART NUMBER: A076K543	PART REVISION: B	DRAWING SPECIFICATION DESCRIPTION	
PART NAME: ARRANGEMENT.GENERATOR GENERAL		A7-D, 6P, 2B, SAE00, STD T-BOX, CH-450	
DRAWING CATEGORY: OUTLINE		Cummins Generator Technologies	
STATE: RELEASED	SHEET: 1 OF 2	DIMENSIONS ARE IN: MILLIMETERS	SIZE: A0 SCALE: 1:1
CUMMINS DATA CLASSIFICATION: CUMMINS CONFIDENTIAL		1 ARE IN:	THIRD ANGLE PROJECTION
THIS DOCUMENT (AND THE INFORMATION SHOWN THEREON) IS CONFIDENTIAL AND PROPRIETARY AND SHALL NOT BE DISCLOSED TO OTHERS IN HARD COPY OR ELECTRONIC FORM, REPRODUCED BY ANY MEANS, OR USED FOR ANY PURPOSE WITHOUT WRITTEN CONSENT OF CUMMINS INC.		DIMENSIONING AND TOLERANCING PER: ASME Y14.5-2009	CAD SYSTEM: PTC® Creo® Parametric

4

3

2

1

D



Part Number: A076K543

Change Notice	CN00170001	Alternates	
Manufacturer Part (MEP)	No	Usage	Production Only
Release Phase Code	Production (P)	Drawing Specification	Number: DS47151447
External Regulations	No External Regulation		Revision: B

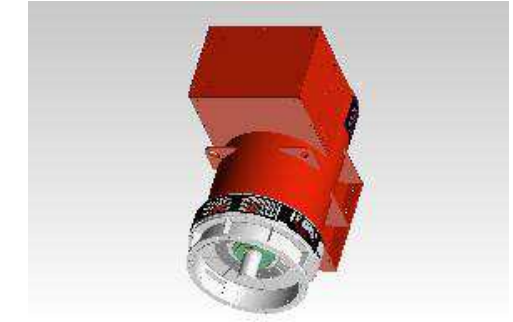

3D image provided when available for visual reference only.

C

Drawing Revision Information

Description of Change(s) Note: Change information is provided for reference only and does not supersede the drawing's primary content.
1. ZONE B-1/2/3/4 : A7-D WAS S7-D
ADMINISTRATIVE CHANGE(S) TO PART ATTRIBUTES, BILL OF MATERIAL, OR ASSOCIATED SPECIFICATIONS.

Drawing Authorization

Drafter	Aishwarya Rajaram Shelar	Date	14FEB2025
Checker	Sneha Pundlikrao Bondlewad	Date	18FEB2025
Approver	Alin Dumitru Visian	Date	18FEB2025

B

A

Cummins Data Classification: **Cummins Confidential** This document (and the information shown thereon) is **Confidential and Proprietary** and shall not be disclosed to others in hard copy or electronic form, reproduced by any means, or used for any purpose without written consent of Cummins Inc.

Part Number: **A076K543** Part Revision: **B**
 Part Name: **ARRANGEMENT,GENERATOR GENERAL**
 Drawing Category: **Outline** State: **Released** Sheet 2 of 2

4

3

2

1