

REL NO	REV	DETAIL	DWN	CKD	APVD	DATE
ECO-170415	D	PRODUCTION RELEASE	KDP	UKD	S. JOSHI	22JUN17
		ZONE D3, DIM 53.6 WAS 51				
		ZONE B3, DIM 32,33.7 & 77.7 WAS 22,28.7 & 72.7				
		TABLE, FAN WT 1.76 WAS 1.676				
		TABLE, FAN MI 0.0182 WAS 0.0172				
		ZONE A3/A4, DIM 18 WAS 19				

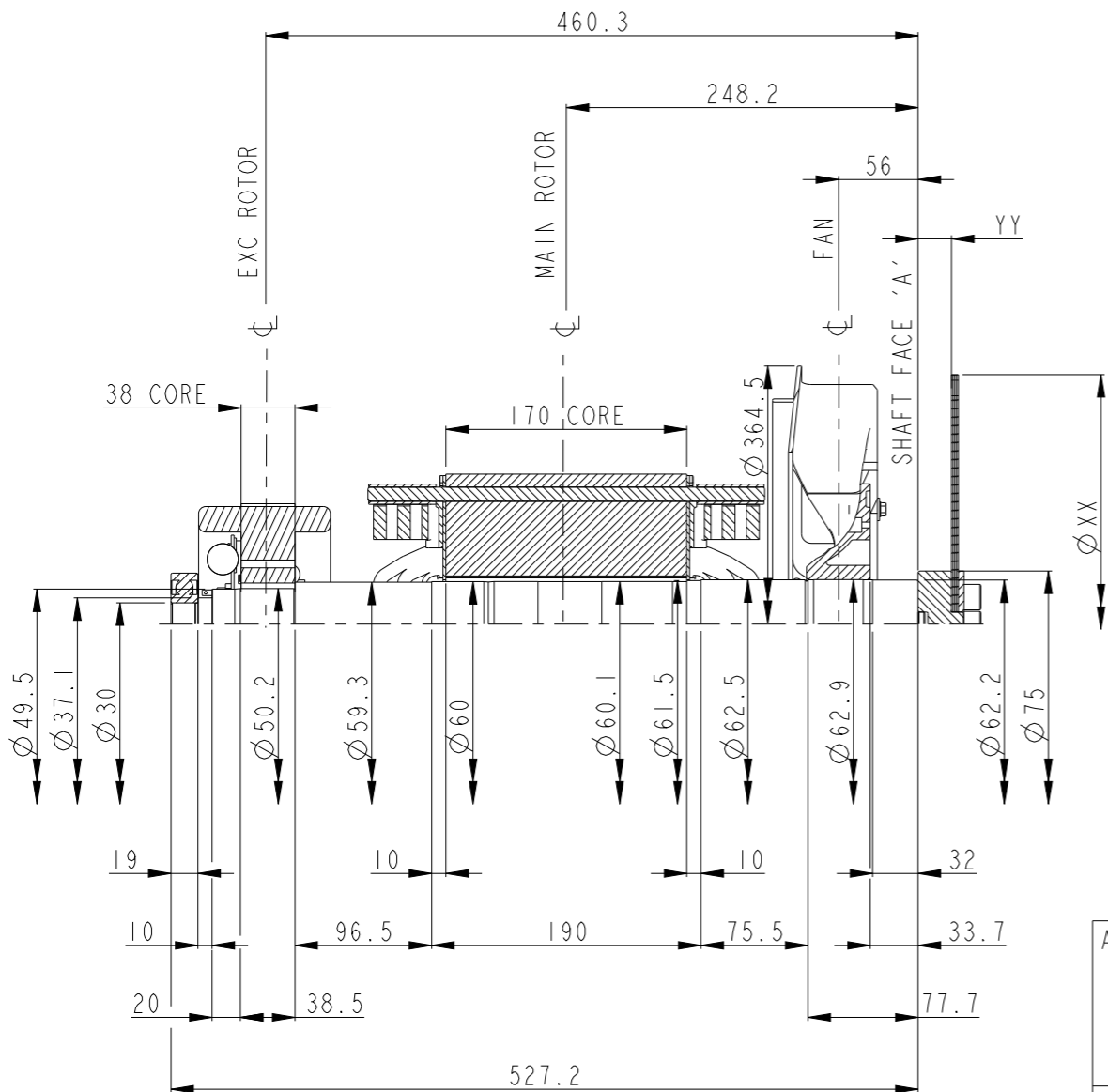

- NOTES:
- SHAFT STIFFNESS:  
THE STIFFNESS OF THE SHAFT BETWEEN THE MAIN ROTOR CORE  $\phi$  AND THE SHAFT FACE 'A' IS  $4.6431 \times 10^6$  kgcm/radian (STIFFENING EFFECT OF MAIN ROTOR CORE IS NOT INCLUDED IN THIS FIGURE)
  - SHAFT MATERIAL:  
STEEL - C40E TO BSEN 10083-2 2006  
MAXIMUM RECOMMENDED VIBRATORY STRESS LEVEL IN THE SHAFT IS  $34.47 \times 10^6$  N/m<sup>2</sup> FOR SPEED RANGE OF 0.95 TO 1.1 X NOMINAL SPEED AND  $68.94 \times 10^6$  N/m<sup>2</sup> FOR RUN THROUGH CONDITIONS, FOR INDUSTRIAL MACHINES
  - CUMMINS GENERATOR TECHNOLOGIES LTD SHOULD BE NOTIFIED OF ANY ROTORS NOT COMPLYING WITH THESE RULES
  - CUMMINS GENERATOR TECHNOLOGIES LTD BALANCE ROTORS TO COMPLY WITH INTERNATIONAL STD BS ISO 1940 PARTS 1 AND 2. BALANCE GRADE 2.5
  - FOR UNBALANCED MAGNETIC PULL (U.M.P) REFER BACK TO THE FACTORY

ADAPTOR SAE No.	COUPLING SAE No.	COUPLING DIMENSIONS		MASS OF DISCS (kg) (4 X 1.2mm THICK)	MASS OF DISCS (kg) (3 X 1.5mm THICK)	MASS OF SHAFT SPACER (kg)	MASS OF PRESSURE PLATE (kg)	TOTAL MASS OF COUPLING ASSEMBLY (kg)	COUPLING STIFFNESS (kgcm/rad)	COUPLING DISC WR <sup>2</sup> (kgm <sup>2</sup> )
		Ø XX mm	YY mm							
3/4	10	314.2	37.97	2.855	-	1.078	0.107	4.040	$23.96 \times 10^6$	0.0354
3	1 1/2	352.3	23.62	3.606	-	0.671	0.107	4.384	$23.84 \times 10^6$	0.0562
3/4	10	314.2	37.97	-	2.676	1.078	0.107	3.861	$22.46 \times 10^6$	0.0332
3	1 1/2	352.3	23.62	-	3.381	0.671	0.107	4.159	$22.35 \times 10^6$	0.0526

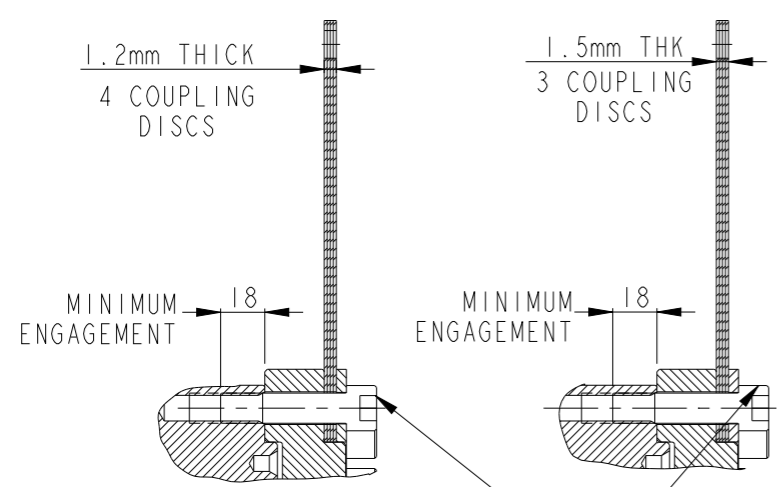

SECTION B-B  
SCALE 1:2

6 EQUI-SPACED SOCKET HEAD SCREW  
M12 X 1.75 PITCH ON 44 PCD  
TORQUE 147 Nm

CONVERSION FACTORS		
TO CONVERT	TO	DIVIDE BY
kg	lb	0.453592
kg m <sup>2</sup>	lb ft <sup>2</sup>	0.04214
kgcm/rad	lbin/rad	1.1521246
N/m <sup>2</sup>	lbf/in <sup>2</sup>	6894.76

COMPONENT	Wt Kg	WR <sup>2</sup> Kgm <sup>2</sup>
FAN	1.76	0.0182
SHAFT	10.97	0.0048
MAIN ROTOR	40.22	0.2324
EXCITER ROTOR	6.20	0.0249
TOTAL	59.15	0.2803

UNLESS OTHERWISE SPECIFIED, ALL DIMENSIONS ARE IN MILLIMETERS		SIM TO -		DWN U. MAGAR				CUMMINS GENERATOR TECHNOLOGIES															
DO NOT SCALE PRINT				CKD U. DAGWALE				DRAWING, TORSIONAL															
<table border="1"> <thead> <tr> <th>DIM</th> <th>HOLE</th> </tr> </thead> <tbody> <tr> <td>X ± 1</td> <td>0.00-4.99 +0.15/-0.08</td> </tr> <tr> <td>X.X ± 0.1</td> <td>5.00-9.99 +0.20/-0.10</td> </tr> <tr> <td>X.XX ± 0.01</td> <td>10.00-17.49 +0.25/-0.13</td> </tr> <tr> <td></td> <td>17.50-24.99 +0.30/-0.13</td> </tr> </tbody> </table>		DIM	HOLE	X ± 1	0.00-4.99 +0.15/-0.08	X.X ± 0.1	5.00-9.99 +0.20/-0.10	X.XX ± 0.01	10.00-17.49 +0.25/-0.13		17.50-24.99 +0.30/-0.13	<table border="1"> <thead> <tr> <th>DATE</th> <th>FIRST USED ON</th> </tr> </thead> <tbody> <tr> <td>15FEB16</td> <td></td> </tr> </tbody> </table>		DATE	FIRST USED ON	15FEB16		APVD S. JOSHI		SITE CODE		SIL2-J1 4P	
DIM	HOLE																						
X ± 1	0.00-4.99 +0.15/-0.08																						
X.X ± 0.1	5.00-9.99 +0.20/-0.10																						
X.XX ± 0.01	10.00-17.49 +0.25/-0.13																						
	17.50-24.99 +0.30/-0.13																						
DATE	FIRST USED ON																						
15FEB16																							
ANG TOL: ± 0.5°		SCALE: 1:4		- CONFIDENTIAL - PROPERTY OF CUMMINS GENERATOR TECHNOLOGIES		PUN		<table border="1"> <thead> <tr> <th>DWG SIZE</th> <th>SHEET</th> <th>REV</th> </tr> </thead> <tbody> <tr> <td>A2</td> <td>1</td> <td>D</td> </tr> </tbody> </table>		DWG SIZE	SHEET	REV	A2	1	D								
DWG SIZE	SHEET	REV																					
A2	1	D																					
				DATE 15FEB16		A053H366																	