

STAMFORD®

S7H1D-F4 Wdg.83 - Technical Data Sheet

Standards

STAMFORD industrial alternators meet the requirements of the relevant parts of the IEC EN 60034 and the relevant section of other international standards such as BS5000, VDE 0530, NEMA MG1-32, IEC34, CSA C22.2-100 and AS1359. Other standards and certifications can be considered on request.

Quality Assurance

Alternators are manufactured using production procedures having a quality assurance level to BS EN ISO 9001.

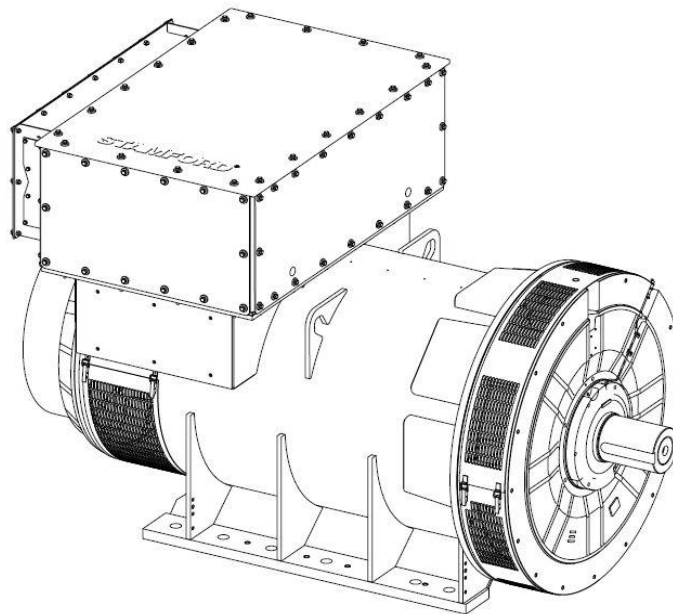

Excitation and Voltage Regulators

Excitation System					
AVR Type	DECS100				
Voltage Regulation	± 0.25%				with 4% Engine Governing
AVR Power	PMG				

No Load Excitation Voltage (V)	16
No Load Excitation Current (A)	0.8
Full Load Excitation Voltage (V)	67
Full Load Excitation Current (A)	3.07
Exciter Time Constant (seconds)	0.22

STAMFORD®

S7H1D-F4 Wdg.83

Electrical Data		
Insulation System	H	
Stator Winding	Double Layer Lap	
Winding Pitch	5/6	
Winding Leads	6	
Winding Number	83	
Number of Poles	4	
IP Rating	IP23	
RFI Suppression	BS EN 61000-6-2 & BS EN 61000-6-4, VDE 0875G, VDE 0875N. Refer to factory for others	
Waveform Distortion	NO LOAD < 1.5% NON-DISTORTING BALANCED LINEAR LOAD < 5.0%	
Short Circuit Ratio	1/Xd	
Steady State X/R Ratio	24.59	
50 Hz		
Telephone Interference	THF<2%	
Cooling Air Flow	2.231 m³/sec	
Voltage Star (V)	10500	11000
Voltage Parallel Star (V)	-	-
Voltage Delta (V)	-	-
kVA Base Rating (Class H) for Reactance Values (kVA)	1625	1625
Saturated Values in Per Unit at Base Ratings and Voltages		
Xd Dir. Axis Synchronous	2.84	2.59
X'd Dir. Axis Transient	0.21	0.20
X''d Dir. Axis Subtransient	0.16	0.15
Xq Quad. Axis Reactance	1.84	1.68
X''q Quad. Axis Subtransient	0.31	0.29
XL Stator Leakage Reactance	0.11	0.10
X2 Negative Sequence Reactance	0.20	0.18
X0 Zero Sequence Reactance	0.19	0.17
Unsaturated Values in Per Unit at Base Ratings and Voltages		
Xd Dir. Axis Synchronous	3.41	3.11
X'd Dir. Axis Transient	0.25	0.22
X''d Dir. Axis Subtransient	0.19	0.17
Xq Quad. Axis Reactance	1.90	1.73
X''q Quad. Axis Subtransient	0.38	0.34
XL Stator Leakage Reactance	0.12	0.11
Xlr Rotor Leakage Reactance	0.13	0.12
X2 Negative Sequence Reactance	0.24	0.22
X0 Zero Sequence Reactance	0.22	0.20

STAMFORD®

S7H1D-F4 Wdg.83

Time Constants (Seconds)		
T'd Transient Time Const.		0.127
T''d Sub-Transient Time Const.		0.018
T'do O.C. Field Time Const.		3.180
Ta Armature Time Const.		0.037
T''q Sub-Transient Time Const.		0.012
Resistances in Ohms (Ω) at 22°C		
Stator Winding Resistance (Ra), per phase for series connected		0.843
Rotor Winding Resistance (Rf)		2.488
Exciter Stator Winding Resistance		19.56
Exciter Rotor Winding Resistance per phase		0.103
PMG Phase Resistance (Rpmg) per phase		1.91
Positive Sequence Resistance (R1)		1.054
Negative Sequence Resistance (R2)		1.214
Zero Sequence Resistance (R0)		1.054
Saturation Factors		11000V
SG1.0		0.193
SG1.2		0.709
Mechanical Data		
Shaft and Keys	All alternator rotors are dynamically balanced to better than BS6861: Part 1 Grade 2.5 for minimum vibration in operation. Two bearing generators are balanced with a half key.	
	1 Bearing	2 Bearing
SAE Adaptor	SAE00,0	SAE00,0
Moment of Inertia	32.0534 kgm ²	32.0751 kgm ²
Weight Wound Stator	1507kg	1494kg
Weight Wound Rotor	791kg	791kg
Weight Complete Alternator	4118kg	3996kg
Shipping weight in a Crate	4198kg	4076kg
Packing Crate Size	2400*1400*1600(cm)	2400*1400*1600(cm)
Maximum Over Speed	2250 RPM for two minutes	
Bearing Drive End	-	BALL 6232
Bearing Non-Drive End	BALL 6319	BALL 6319

STAMFORD®

S7H1D-F4 Wdg.83

THREE PHASE EFFICIENCY CURVES

50Hz

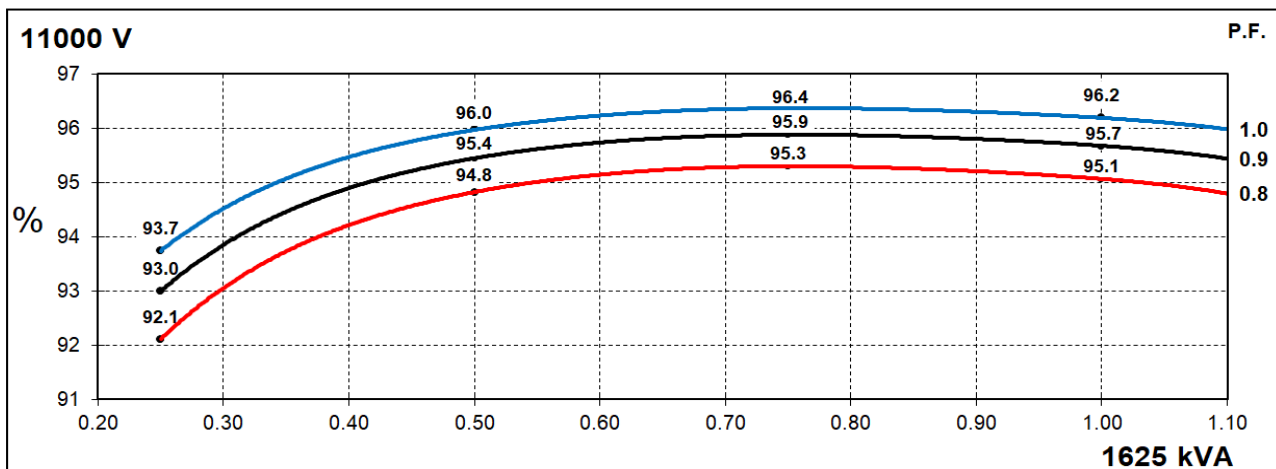
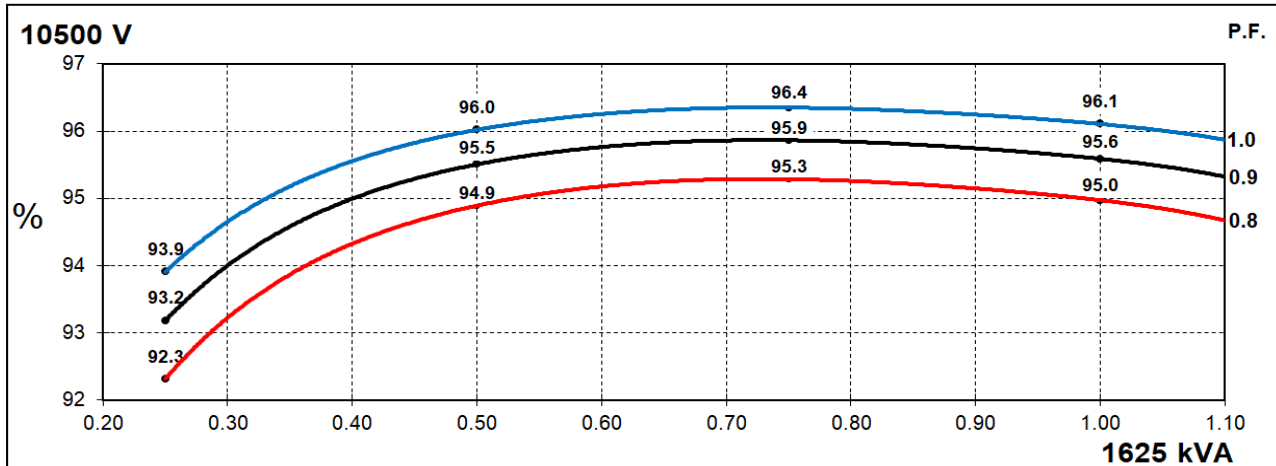

STAMFORD

S7H1D-F4 Wdg.83

Locked Rotor Motor Starting Curves - Separately Excited

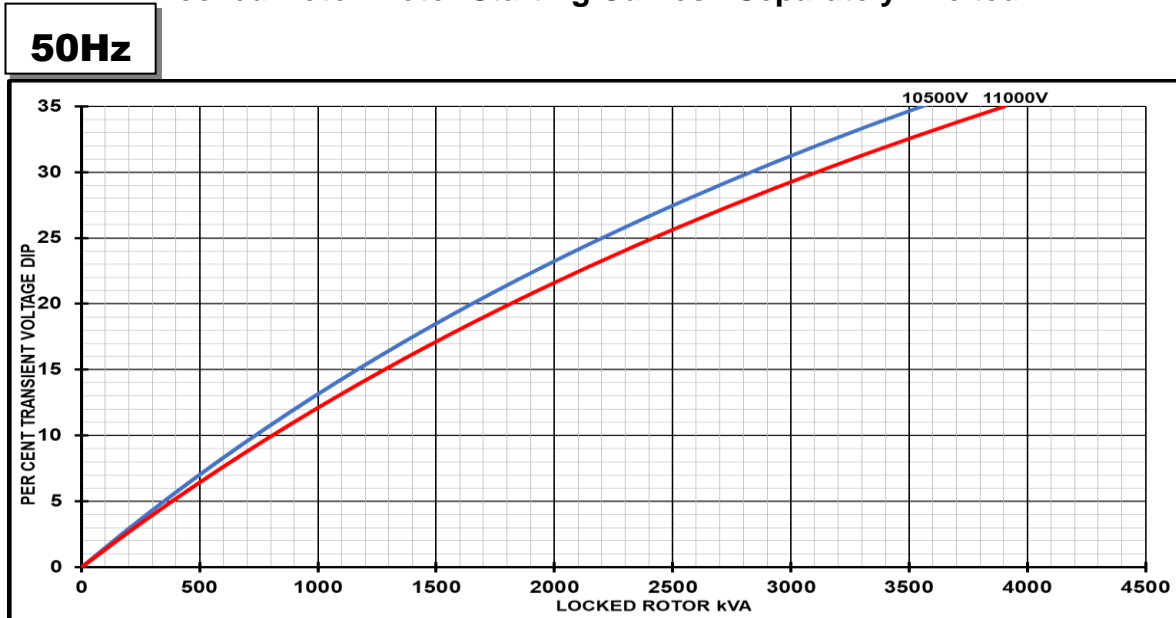

Transient Voltage Dip Scaling Factor		Transient Voltage Rise Scaling Factor	
Lagging PF	Scaling Factor	Lagging PF	Scaling Factor
<= 0.4	1.00	<= 0.4	1.25
0.5	0.95	0.5	1.20
0.6	0.90	0.6	1.15
0.7	0.86	0.7	1.10
0.8	0.83	> 0.7	1.00
0.9	0.75		
0.95	0.70		
1	0.65		

Note: To determine % Transient Voltage Dip or Voltage Rise at various PF, multiply the % Voltage Dip from the curve directly by the Scaling Factor.

STAMFORD®

S7H1D-F4 Wdg.83

Three-phase Short Circuit Decrement Curve - Separately Excited

50Hz

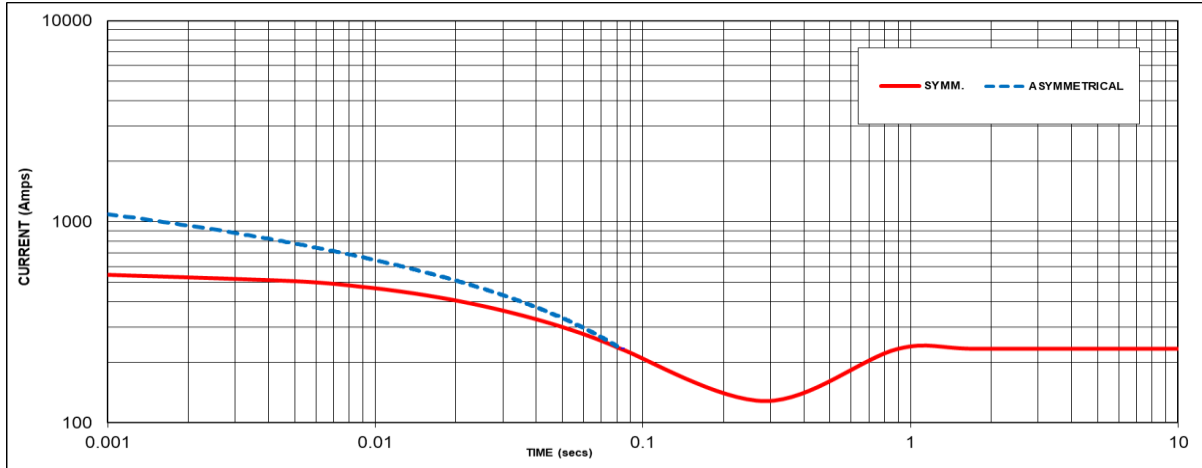

Sustained Short Circuit = 234 Amps

Note 1

The following multiplication factors should be used to adjust the values from curve between time 0.001 seconds and the minimum current point in respect of nominal operating voltage :

50Hz		60Hz	
Voltage	Factor	Voltage	Factor
10500V	X 0.95	-	-
11000V	X 1.00	-	-
-	-	-	-
-	-	-	-

The sustained current value is constant irrespective of voltage level

Note 2

The following multiplication factor should be used to convert the values calculated in accordance with NOTE 1 to those applicable to the various types of short circuit :

	3-phase	2-phase L-L	1-phase L-N
Instantaneous	x 1.00	x 0.87	x 1.30
Minimum	x 1.00	x 1.80	x 3.20
Sustained	x 1.00	x 1.50	x 2.50
Max. sustained duration	10 sec.	5 sec.	2 sec.

Note 3

All other times are unchanged
 Curves are drawn for Star connections under no-load excitation at rated speeds. For other connection (where applicable) the following multipliers should be applied to current values as shown :
 Parallel Star = Curve current value X 2
 Series Delta = Curve current value X 1.732

STAMFORD

S7H1D-F4 Wdg.83

Typical Alternator Operating Charts

11000V/50Hz

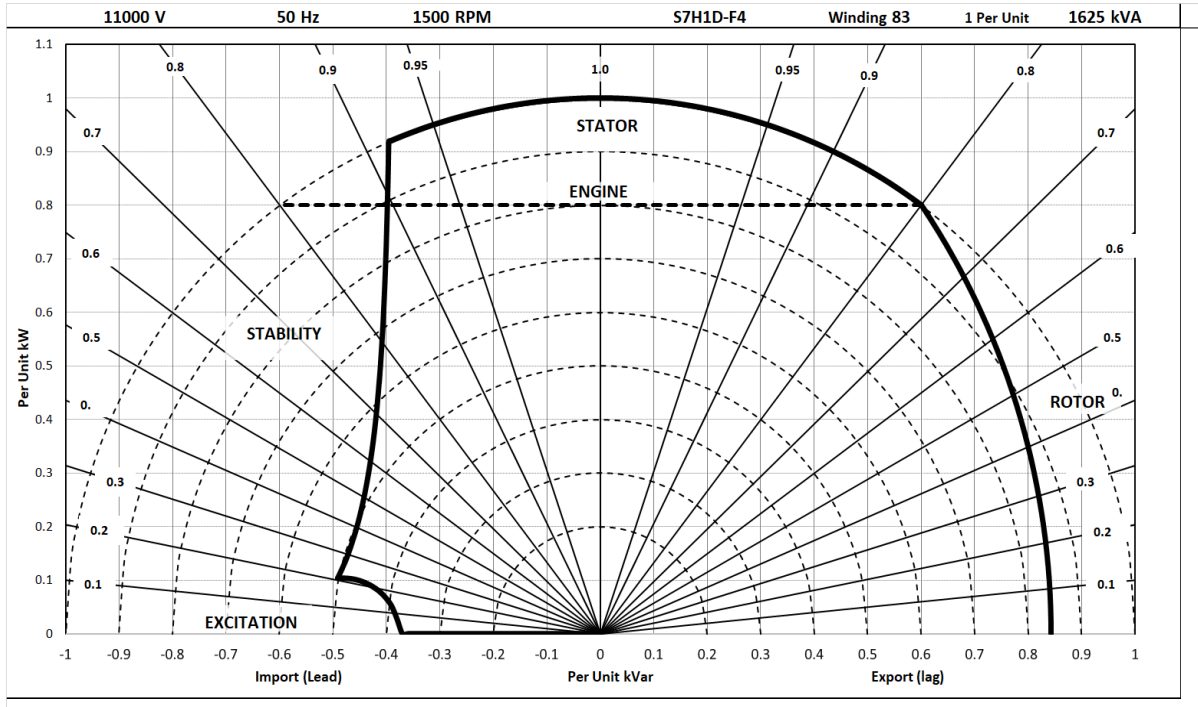

STAMFORD®

S7H1D-F4 Wdg.83

RATINGS AT 0.8 POWER FACTOR

Class - Temp Rise	Standby - 163/27°C		Standby - 150/40°C		Cont. H - 125/40°C		Cont. F - 105/40°C		
50 Hz	Star (V)	10500	11000	10500	11000	10500	11000	10500	11000
	Parallel Star (V)	N/A	N/A	N/A	N/A	N/A	N/A	N/A	N/A
	Delta (V)	N/A	N/A	N/A	N/A	N/A	N/A	N/A	N/A
	kVA	1785	1785	1735	1735	1625	1625	1500	1500
	kW	1428	1428	1388	1388	1300	1300	1200	1200
	Efficiency (%)	94.7	94.8	94.8	94.9	95.0	95.1	95.1	95.2
	kW Input	1508	1506	1464	1462	1369	1367	1261	1260

60 Hz	Star (V)	N/A	N/A	N/A	N/A	N/A	N/A
	Parallel Star (V)	N/A	N/A	N/A	N/A	N/A	N/A
	Delta (V)	N/A	N/A	N/A	N/A	N/A	N/A
	kVA	N/A	N/A	N/A	N/A	N/A	N/A
	kW	N/A	N/A	N/A	N/A	N/A	N/A
	Efficiency (%)	N/A	N/A	N/A	N/A	N/A	N/A
	kW Input	N/A	N/A	N/A	N/A	N/A	N/A

De-rates

All values tabulated above are subject to the following reductions:

- 5% when air inlet filters are fitted
- 3% for every 500 meters by which the operating altitude exceeds 1000 meters above mean sea level
- 3% for every 5°C by which the operational ambient temperature exceeds 40°C @ Class H temperature rise (please refer to applications for ambient temperature de-rates at other temperature rise classes)
- For any other operating conditions impacting the cooling circuit please refer to applications

Note: Requirement for operating in an ambient exceeding 60°C and altitude exceeding 4000 meters (for <690V) or 1500 meters (for >690V) must be referred to applications.

Dimensional and Torsional Drawing

For dimensional and torsional information please refer to the alternator General Arrangement and rotor drawings available on our website (<http://stamford-avk.com/>)

Note: Continuous development of our products means that the information contained in our data sheets can change without notice, and specifications should always be confirmed with Cummins Generator Technologies prior to purchase.



Follow us @stamfordavk



Cummins Generator Technologies



View our videos at youtube.com/stamfordavk

news.stamford-avk.com

For Applications Support:
applications@cummins.com

For Customer Service:
cgt.china.service@cummins.com

For General Enquiries:
Stamford-avk@cummins.com

Copyright 2016. Cummins Generator Technologies Ltd. All rights reserved.
Cummins and the Cummins logo are registered trade marks of Cummins Inc.
STAMFORD is a registered trade mark of Cummins Generator Technologies Ltd.

