

DL15-12560 ISSUE C

IF IN DOUBT-ASK  
DO NOT SCALE

FIRST W.O.

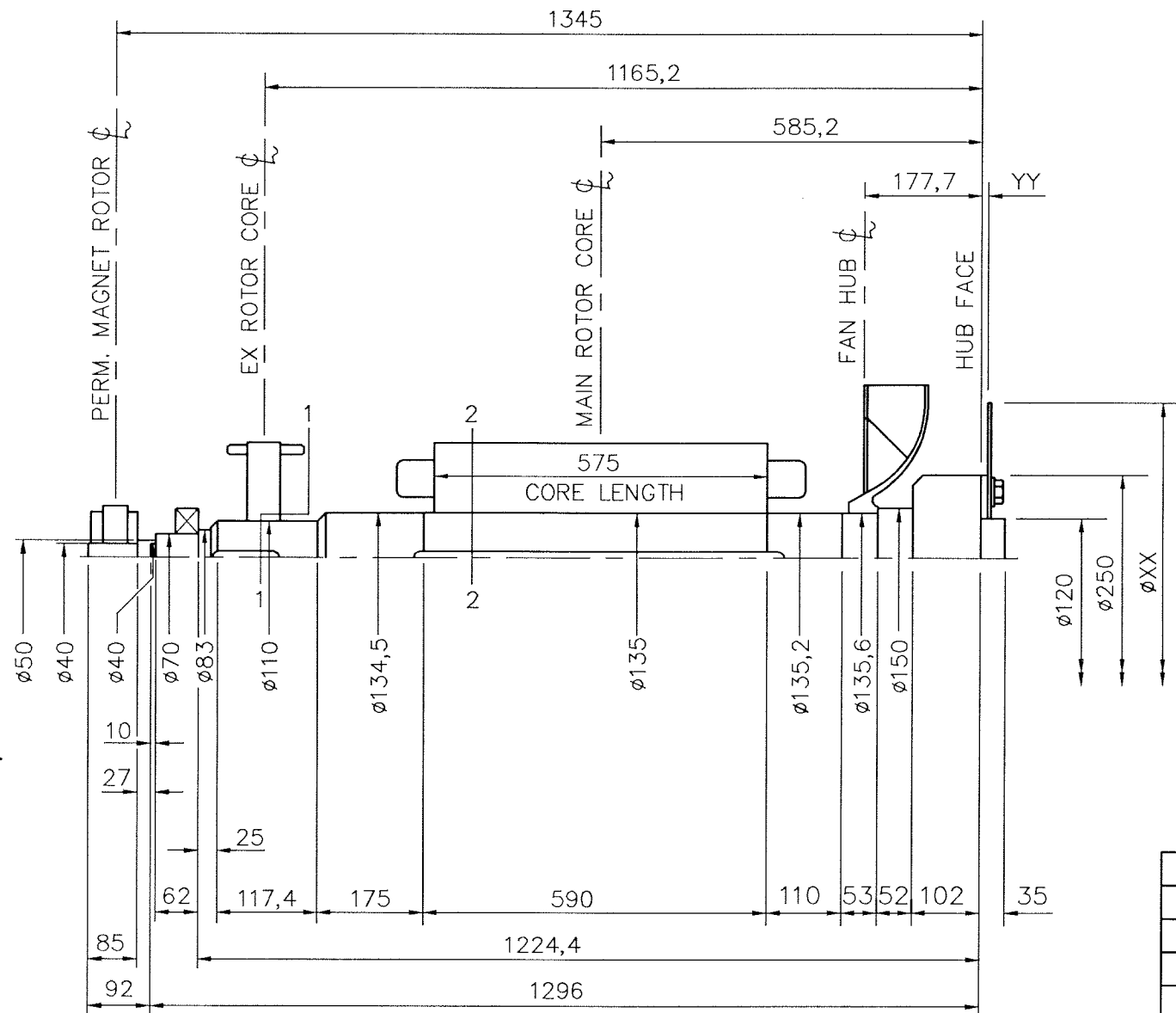

NOTES!

SHAFT STIFFNESS: -

THE STIFFNESS OF THE SHAFT BETWEEN THE MAIN ROTOR CORE  $\phi$  AND THE COUPLING HUB FACE IS  $51,69 \times 10^6$  kgcm/radian (STIFFENING EFFECT OF MAIN ROTOR CORE IS NOT INCLUDED IN THIS FIGURE)

SHAFT MATERIAL: -

STEEL - 080M40 TO BS970 PART 1 (APPROVED BY MARINE AUTHORITIES WHEN APPROPRIATE).

MAXIMUM RECOMMENDED VIBRATORY STRESS LEVEL IN THE SHAFT IS  $34,47 \times 10^6$  N/m<sup>2</sup> FOR A SPEED RANGE OF 0,95 TO 1,1 x NOMINAL SPEED, AND  $68,94 \times 10^6$  N/m<sup>2</sup> FOR RUN THROUGH CONDITIONS, FOR INDUSTRIAL MACHINES.

FOR MARINE AUTHORITIES, THEIR APPROPRIATE RULES WILL APPLY.

NEWAGE INTERNATIONAL LTD. SHOULD BE NOTIFIED OF ANY ROTORS NOT COMPLYING WITH THESE RULES.

NEWAGE INTERNATIONAL LTD. BALANCE ROTORS TO COMPLY WITH INTERNATIONAL STD. I.S.O. 1940 GRADE 2,5 AND B.S. 6861 PART 1 GRADE 2,5.

FOR UNBALANCED MAGNETIC PULL (U.M.P.) FORCES REFER TO GENERATOR MANUAL.

COMPONENT	Wt kg	WR <sup>2</sup> kgm <sup>2</sup>	COUPLING SAE No	COUPLING DIMEN's		COUPLING ASSEMBLY WEIGHT kg	COUPLING STIFFNESS 4-PLATES kgcm/rad	COUPLING DISC WR <sup>2</sup> kg m <sup>2</sup>
				XX	YY			
EX. ROTOR	31,290	0,5100	-	450,9	18,2	14,97	675,0x10 <sup>6</sup>	0,152
MAIN ROTOR	470,000	8,5600						
FAN	12,530	0,3930						
SHAFT	138,092	0,3062	$\phi 17,75"$	18,2	14,97	675,0x10 <sup>6</sup>	0,152	
HUB	23,922	0,2455	14	467	25,4	17,67	632,0x10 <sup>6</sup>	0,174
P.M. STUB SHAFT	0,929	0,0003	18	572	16,0	18,06	579,0x10 <sup>6</sup>	0,396
P.M. EX. ROTOR	6,970	0,0180	21	673	0,0	17,10	554,0x10 <sup>6</sup>	0,756
-	-	-	-	-	-	-	-	-
TOTAL	683,733	10,033	-	-	-	-	-	-

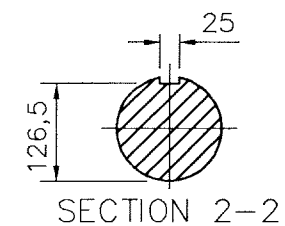
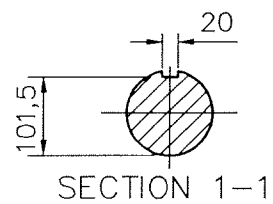
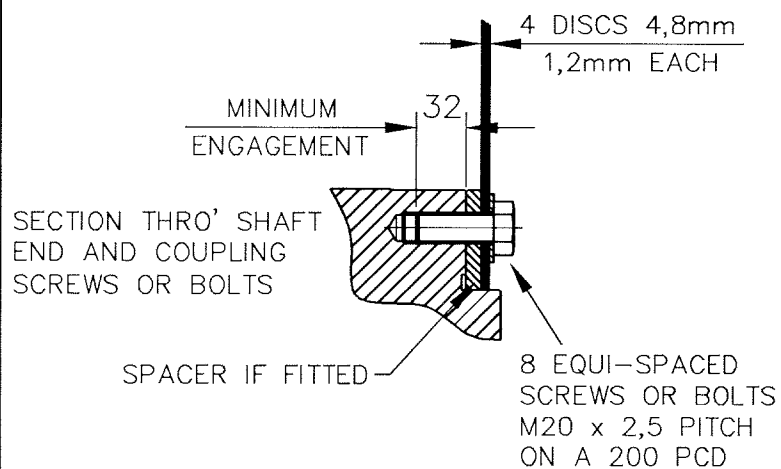

MOD'N	ISSUE	DRAWN	DATE	ALTERATION
4/3956/1	C	AV	29:10:02	COUPLING SAE21 ADDED SAE 11,5 DELETED
4/3242/4	B	SMC	13.02.02	COUPLING DETAIL MODIFIED
4/3000/2	A	SMC	28.06.00	ORIGINAL ISSUE

CONVERSION FACTORS		
TO CONVERT	TO	DIVIDE BY
kg	lb	0,453592
kg m <sup>2</sup>	lb ft <sup>2</sup>	0,04214
kgcm/rad	lbin/rad	1,1521246
N/m <sup>2</sup>	lbf/in <sup>2</sup>	6894,76

CERTIFIED PRINT (ONLY IF SIGNED)		
BY	DATE	
DRAWN	SMC	28.06.00
CHECKED		30-10-02
APPROVED		30/10/02

HC534 1F - SINGLE BEARING MOMENTS OF INERTIA AND SHAFT DETAILS

**NEWAGE INTERNATIONAL Ltd**  
STAMFORD ENGLAND

SCALE	FIRST W.O.
NTS	
	UNIT OF MEASUREMENT MILLIMETRES (mm)
DL15-12560	ISSUE C