

REL NO	REV	NO	REVISION	DWN	CKD	APVD	DATE
ECO-180669	B	1	SEE ECO DESCRIPTION	TVK	DGL	K.WEJRZANOWSKI	05DEC18

NOTES:

- SHAFT STIFFNESS:-
THE STIFFNESS OF THE SHAFT BETWEEN THE MAIN ROTOR CORE ϕ AND THE COUPLING HUB FACE IS 60.33×10^6 kgcm/radian (STIFFENING EFFECT OF MAIN ROTOR CORE IS NOT INCLUDED IN THIS FIGURE)
- SHAFT PROPERTIES:
MINIMUM YIELD : 260MPA
MINIMUM ULTIMATE TENSILE STRENGTH : 530MPA
SHAFT MATERIAL IS APPROVED BY MARINE AUTHORITIES WHEN APPROPRIATE
- MAXIMUM RECOMMENDED VIBRATORY STRESS LEVEL IN THE SHAFT IS 34.47×10^6 N/M² FOR A SPEED RANGE OF 0.95 TO 1.1 X NOMINAL SPEED AND 68.94×10^6 N/M² FOR RUN THROUGH CONDITIONS FOR INDUSTRIAL MACHINES.
- FOR MARINE AUTHORITIES, THEIR APPROPRIATE RULES WILL APPLY
- CUMMINS GENERATOR TECHNOLOGIES LTD SHOULD BE NOTIFIED OF ANY ROTORS NOT COMPLYING WITH THESE RULES
- CUMMINS GENERATOR TECHNOLOGIES LTD BALANCE ROTORS TO COMPLY WITH INTERNATIONAL STD ISO 1940 GRADE 2.5 AND BS 6861 PART 1 GRADE 2.5
- FOR UNBALANCED MAGNETIC PULL (U.M.P) FORCES PLEASE CONTACT CUMMINS GENERATOR TECHNOLOGIES LTD

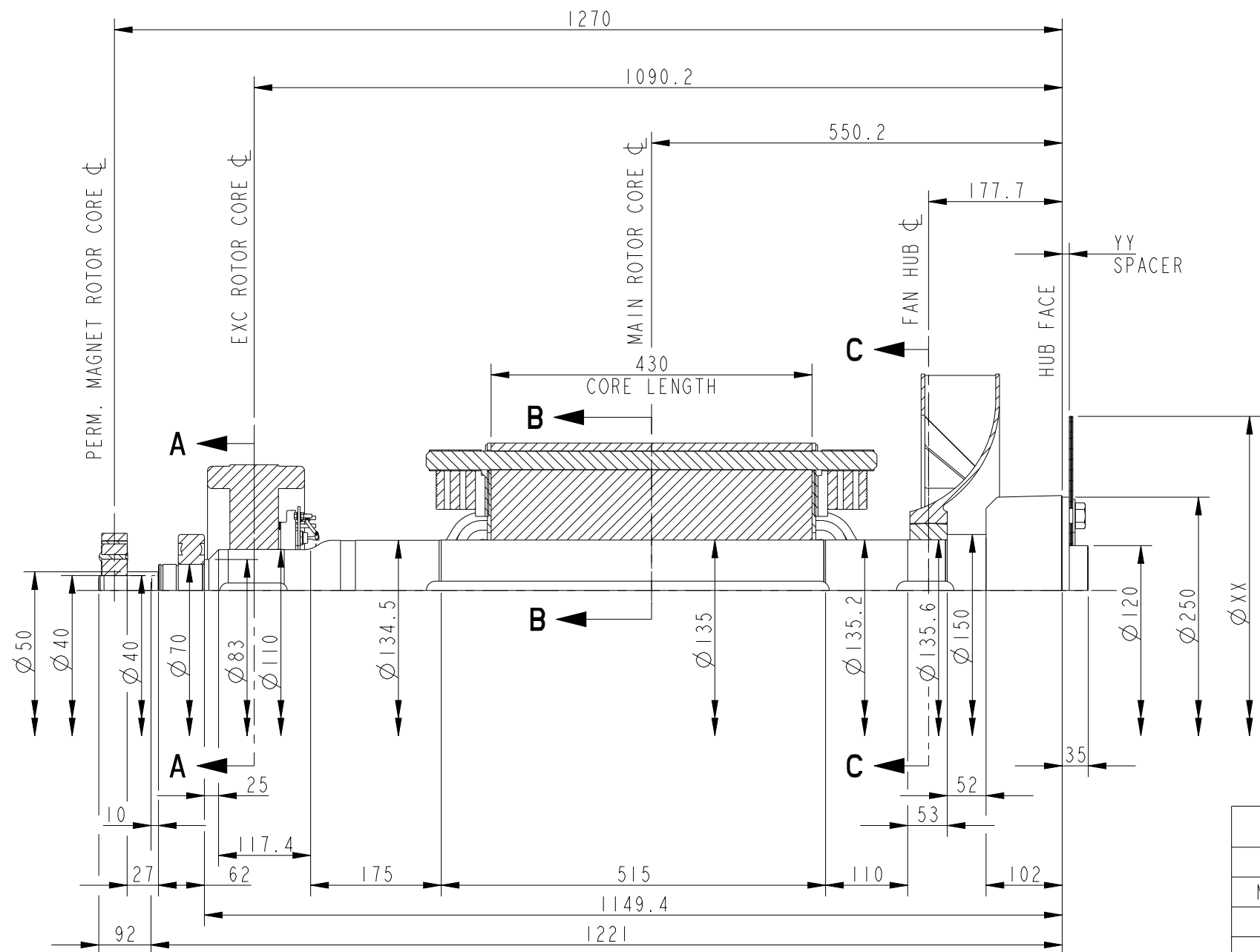

COMPONENT	WT (Kg)	WR ² kgm ²
EX. ROTOR	31.290	0.5100
MAIN ROTOR	358.090	6.5530
FAN	12.530	0.3930
SHAFT	129.664	0.2870
HUB	23.922	0.2455
PM STUB SHAFT	0.929	0.0003
PM EXC ROTOR	6.970	0.0180
TOTAL	563.395	8.0068

CONVERSION FACTORS		
TO CONVERT	TO	DIVIDE BY
Kg	lb	0.453592
Kgm ²	lb ft ²	0.04214
Kgcm/rad	lbin/rad	1.1521246
N/M ²	ibf/in ²	6894.76

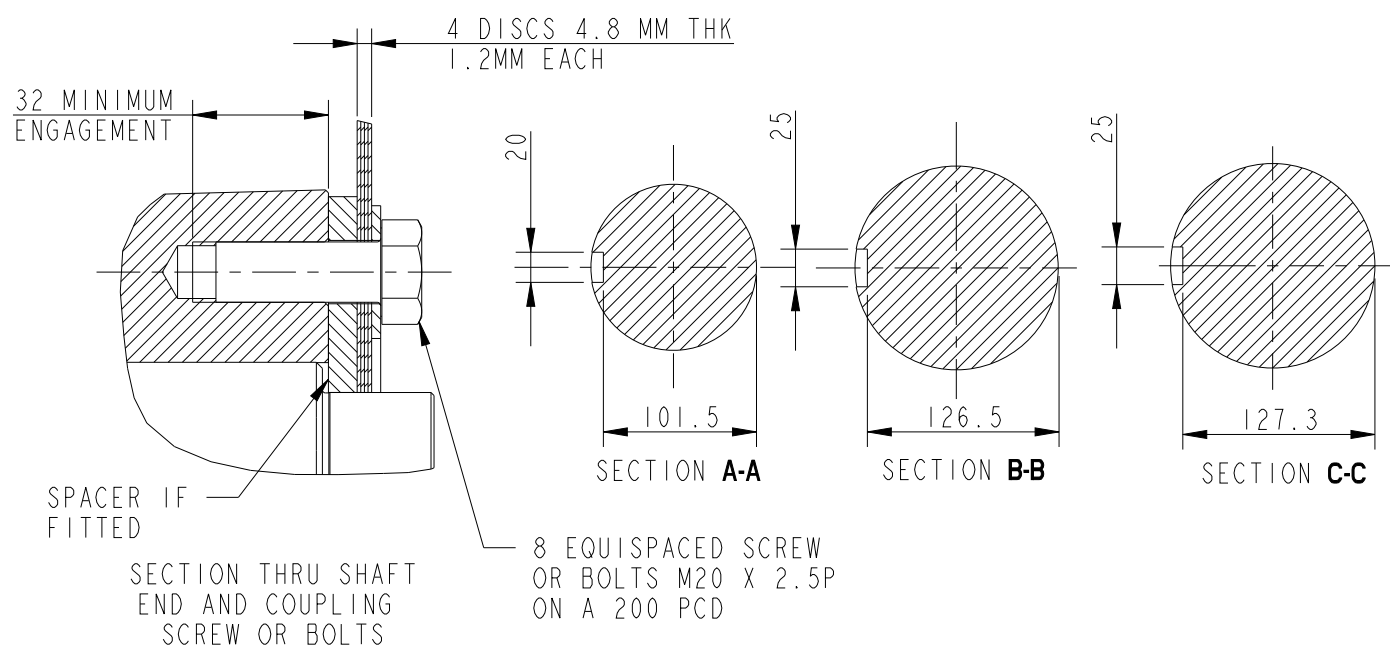

COUPLING SAE NO	COUPLING DIMENSIONS		COUPLING ASSEMBLY WEIGHT (Kg)	COUPLING STIFFNESS 4-PLATES (Kgcm/rad)	COUPLING DISC WR ² (Kgm ²)
	XX	YY			
14	467	25.4	17.67	632×10^6	0.174
18	572	16.0	18.06	579×10^6	0.396
21	673	0	17.10	554×10^6	0.756
$\phi 17.75"$	450.9	18.2	14.97	675×10^6	0.152

UNLESS OTHERWISE SPECIFIED, ALL DIMENSIONS ARE IN MILLIMETERS

SCALE 1:1

THIS DOCUMENT (AND THE INFORMATION SHOWN THEREON) IS CONFIDENTIAL AND PROPRIETARY AND SHALL NOT BE DISCLOSED TO OTHERS IN HARD COPY OR ELECTRONIC FORM, REPRODUCED BY ANY MEANS, OR USED FOR ANY PURPOSE WITHOUT WRITTEN CONSENT OF CUMMINS INC.

SIM TO L15-12560

DO NOT SCALE PRINT

DWN V. SHIPPARKAR

CKD P. NAIK

APVD M. VUCENOVIC

DATE 08MAR18

FIRST USED ON S5

FOR INTERPRETATION OF DIMENSIONING AND TOLERANCING, SEE ASME Y14.5-2009

CUMMINS GENERATOR TECHNOLOGIES

DRAWING, TORSIONAL

S5L1D, S5L1M, S5L1S, D-CORE 4P 1B

STA A2

A059K284

CAD SHEET 1 of 1