

## S4L1M-F41 Wdg.13 - Technical Data Sheet

### Standards

STAMFORD industrial alternators meet the requirements of the relevant parts of the IEC EN 60034 and the relevant section of other international standards such as BS5000, VDE 0530, NEMA MG1-32, IEC34, CSA C22.2-100 and As1359. Other standards and certifications can be considered on request.

### Quality Assurance

Alternators are manufactured using production procedures having a quality assurance level to BS EN ISO 9001.

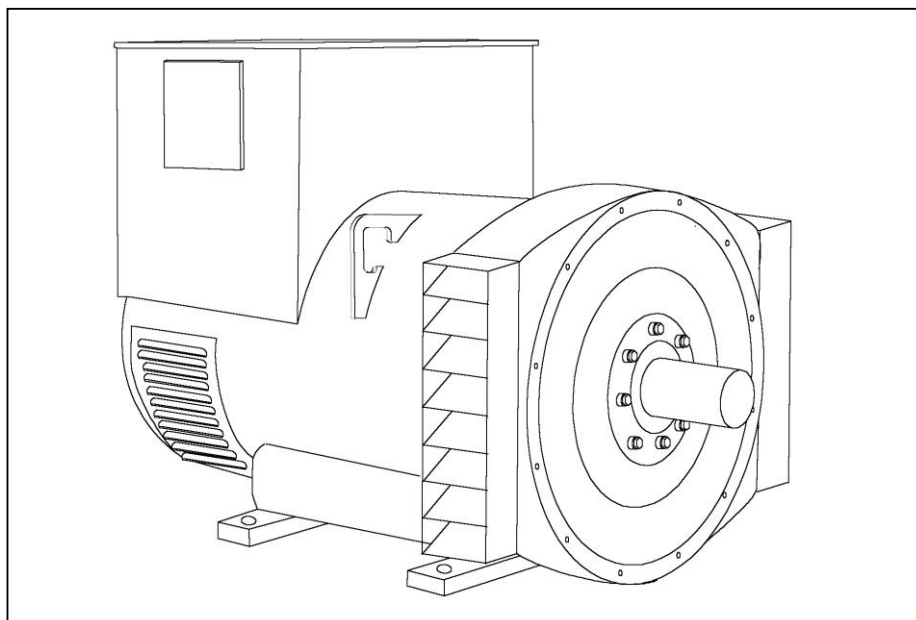

### Excitation and Voltage Regulators

Excitation System					
<b>AVR Type</b>	MX341	MX321			
<b>Voltage Regulation</b>	± 1.0%	± 0.5%			with 4% Engine Governing
<b>AVR Power</b>	PMG	PMG			

<b>No Load Excitation Voltage (V)</b>	10 - 8
<b>No Load Excitation Current (A)</b>	0.6 - 0.4
<b>Full Load Excitation Voltage (V)</b>	41 - 37
<b>Full Load Excitation Current (A)</b>	2.3 - 2.1
<b>Exciter Time Constant (seconds)</b>	0.105

# STAMFORD

## S4L1M-F41 Wdg.13

Electrical Data			
Insulation System	CLASS H		
Stator Winding	DOUBLE LAYER LAP		
Winding Pitch	TWO THIRDS		
Winding Leads	6		
Winding Number	13		
Number of Poles	4		
IP Rating	IP23		
RFI Suppression	BS EN 61000-6-2 & BS EN 61000-6-4, VDE 0875G, VDE 0875N. Refer to factory for others		
Waveform Distortion	NO LOAD < 1.5% NON-DISTORTING BALANCED LINEAR LOAD < 5.0%		
Short Circuit Ratio	1/Xd		
Steady State X/R Ratio	12.2		
60 Hz			
Telephone Interference	TIF<50		
Cooling Air	0.99 m <sup>3</sup> /sec 2100cfm		
Voltage Star	380	400	416
kVA Base Rating (CLASS H) for Reactance Values	425	425	425
Saturated Values in Per Unit at Base Ratings and Voltages			
Xd Dir. Axis Synchronous	2.43	2.19	2.03
X'd Dir. Axis Transient	0.15	0.14	0.13
X''d Dir. Axis Subtransient	0.11	0.10	0.09
Xq Quad. Axis Reactance	2.15	1.94	1.79
X''q Quad. Axis Subtransient	0.32	0.29	0.27
XL Stator Leakage Reactance	0.05	0.05	0.04
X2 Negative Sequence Reactance	0.21	0.19	0.18
X0 Zero Sequence Reactance	0.07	0.06	0.06
Unsaturated Values in Per Unit at Base Ratings and Voltages			
Xd Dir. Axis Synchronous	2.92	2.63	2.43
X'd Dir. Axis Transient	0.17	0.16	0.15
X''d Dir. Axis Subtransient	0.13	0.12	0.11
Xq Quad. Axis Reactance	2.21	2.00	2.15
X''q Quad. Axis Subtransient	0.38	0.35	0.32
XL Stator Leakage Reactance	0.06	0.05	0.05
Xlr Rotor Leakage Reactance	0.10	0.09	0.08
X2 Negative Sequence Reactance	0.25	0.23	0.21
X0 Zero Sequence Reactance	0.08	0.07	0.07

# STAMFORD

## S4L1M-F41 Wdg.13

<b>Time Constants (Seconds)</b>																																		
T'd TRANSIENT TIME CONST.	0.08																																	
T''d SUB-TRANSTIME CONST.	0.019																																	
T'do O.C. FIELD TIME CONST.	1.7																																	
Ta ARMATURE TIME CONST.	0.018																																	
T''q SUB-TRANSTIME CONST.	0.0304																																	
<b>Resistances in Ohms (<math>\Omega</math>) at 22<sup>o</sup>C</b>																																		
Stator Winding Resistance (Ra), per phase for series connected	0.006																																	
Rotor Winding Resistance (Rf)	1.37																																	
Exciter Stator Winding Resistance	18																																	
Exciter Rotor Winding Resistance per phase	0.068																																	
PMG Phase Resistance (Rpmg) per phase	1.9																																	
Positive Sequence Resistance (R1)	0.0075																																	
Negative Sequence Resistance (R2)	0.00864																																	
Zero Sequence Resistance (R0)	0.0075																																	
<b>Saturation Factors</b>																																		
	380V																																	
SG1.0	0.25																																	
SG1.2	1.18																																	
<b>Mechanical Data</b>																																		
Shaft and Keys	All alternator rotors are dynamically balanced to better than BS6861: Part 1 Grade 2.5 for minimum vibration in operation. Two bearing generators are balanced with a half key.																																	
	<table border="1"> <thead> <tr> <th></th> <th>1 Bearing</th> <th>2 Bearings</th> </tr> </thead> <tbody> <tr> <td>SAE Adaptor</td> <td>SAE 0, 0.5, 1, 2</td> <td>SAE 0, 0.5, 1, 2</td> </tr> <tr> <td>Moment of Inertia</td> <td>5.4292 kgm<sup>2</sup></td> <td>5.2304 kgm<sup>3</sup></td> </tr> <tr> <td>Weight Wound Stator</td> <td>535 kg</td> <td>535 kg</td> </tr> <tr> <td>Weight Wound Rotor</td> <td>463 kg</td> <td>440 kg</td> </tr> <tr> <td>Weight Complete Alternator</td> <td>1160 kg</td> <td>1160 kg</td> </tr> <tr> <td>Shipping weight in a Crate</td> <td>1230 kg</td> <td>1230 kg</td> </tr> <tr> <td>Packing Crate Size</td> <td>155 x 87 x 107 (cm)</td> <td>155 x 87 x 107 (cm)</td> </tr> <tr> <td>Maximum Over Speed</td> <td colspan="2">2250 RPM for two minutes</td> </tr> <tr> <td>Bearing Drive End</td> <td colspan="2">BALL. 6317 (ISO)</td> </tr> <tr> <td>Bearing Non-Drive End</td> <td colspan="2">BALL. 6314 (ISO)</td> </tr> </tbody> </table>		1 Bearing	2 Bearings	SAE Adaptor	SAE 0, 0.5, 1, 2	SAE 0, 0.5, 1, 2	Moment of Inertia	5.4292 kgm <sup>2</sup>	5.2304 kgm <sup>3</sup>	Weight Wound Stator	535 kg	535 kg	Weight Wound Rotor	463 kg	440 kg	Weight Complete Alternator	1160 kg	1160 kg	Shipping weight in a Crate	1230 kg	1230 kg	Packing Crate Size	155 x 87 x 107 (cm)	155 x 87 x 107 (cm)	Maximum Over Speed	2250 RPM for two minutes		Bearing Drive End	BALL. 6317 (ISO)		Bearing Non-Drive End	BALL. 6314 (ISO)	
	1 Bearing	2 Bearings																																
SAE Adaptor	SAE 0, 0.5, 1, 2	SAE 0, 0.5, 1, 2																																
Moment of Inertia	5.4292 kgm <sup>2</sup>	5.2304 kgm <sup>3</sup>																																
Weight Wound Stator	535 kg	535 kg																																
Weight Wound Rotor	463 kg	440 kg																																
Weight Complete Alternator	1160 kg	1160 kg																																
Shipping weight in a Crate	1230 kg	1230 kg																																
Packing Crate Size	155 x 87 x 107 (cm)	155 x 87 x 107 (cm)																																
Maximum Over Speed	2250 RPM for two minutes																																	
Bearing Drive End	BALL. 6317 (ISO)																																	
Bearing Non-Drive End	BALL. 6314 (ISO)																																	
SAE Adaptor	SAE 0, 0.5, 1, 2	SAE 0, 0.5, 1, 2																																
Moment of Inertia	5.4292 kgm <sup>2</sup>	5.2304 kgm <sup>3</sup>																																
Weight Wound Stator	535 kg	535 kg																																
Weight Wound Rotor	463 kg	440 kg																																
Weight Complete Alternator	1160 kg	1160 kg																																
Shipping weight in a Crate	1230 kg	1230 kg																																
Packing Crate Size	155 x 87 x 107 (cm)	155 x 87 x 107 (cm)																																
Maximum Over Speed	2250 RPM for two minutes																																	
Bearing Drive End	BALL. 6317 (ISO)																																	
Bearing Non-Drive End	BALL. 6314 (ISO)																																	

# STAMFORD®

S4L1M-F41 Wdg.13

## THREE PHASE EFFICIENCY CURVES

60Hz

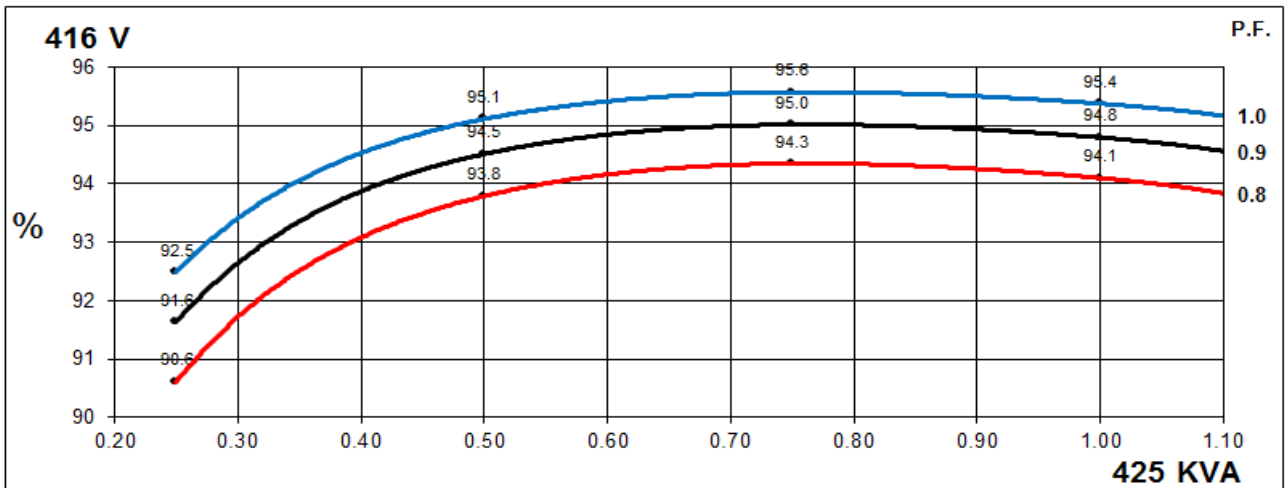
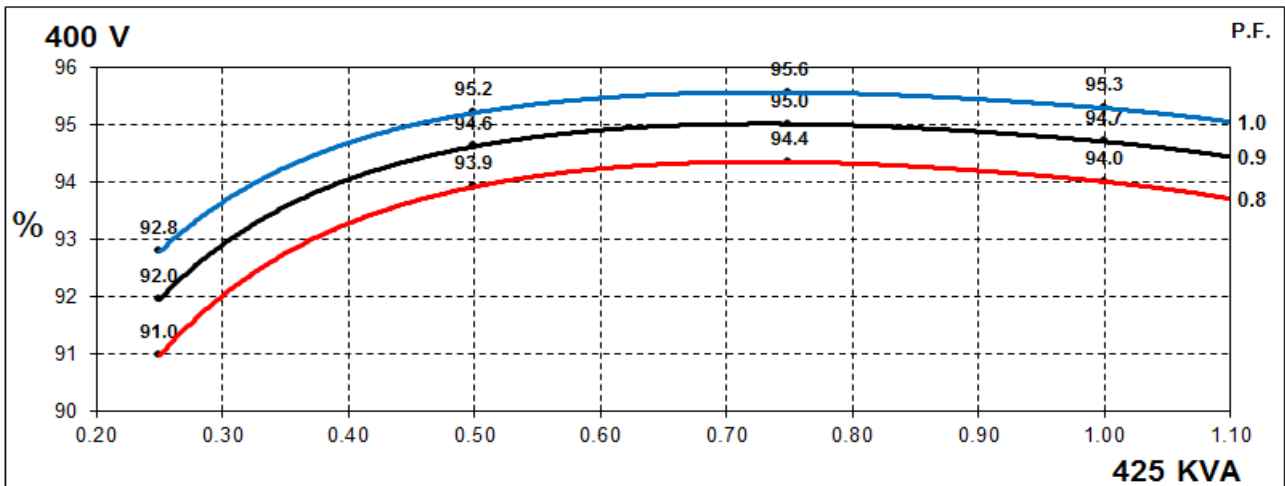
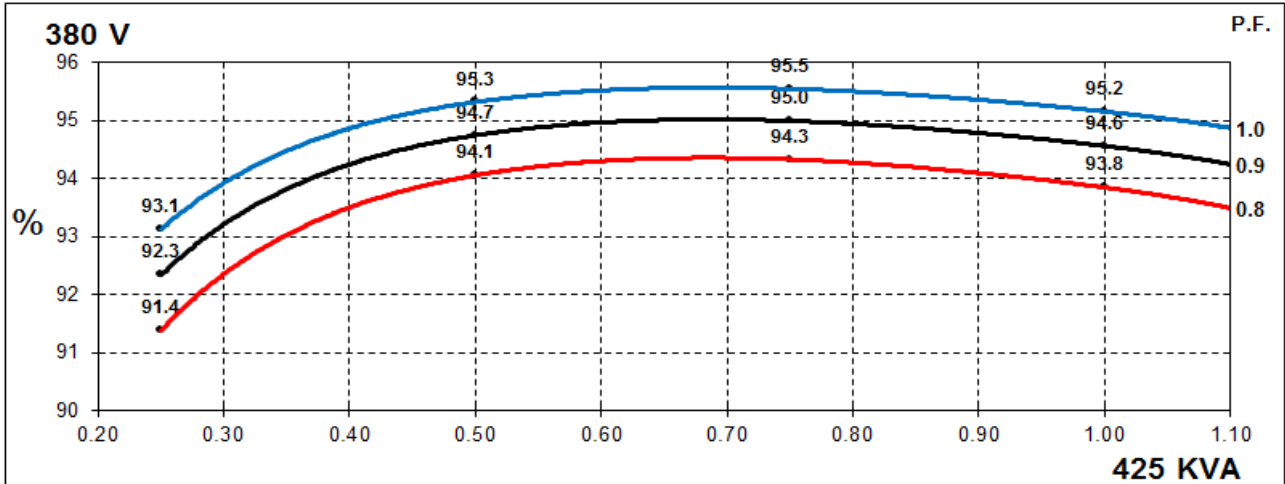

# STAMFORD®

S4L1M-F41 Wdg.13

## Locked Rotor Motor Starting Curves - Separately Excited

**60Hz**

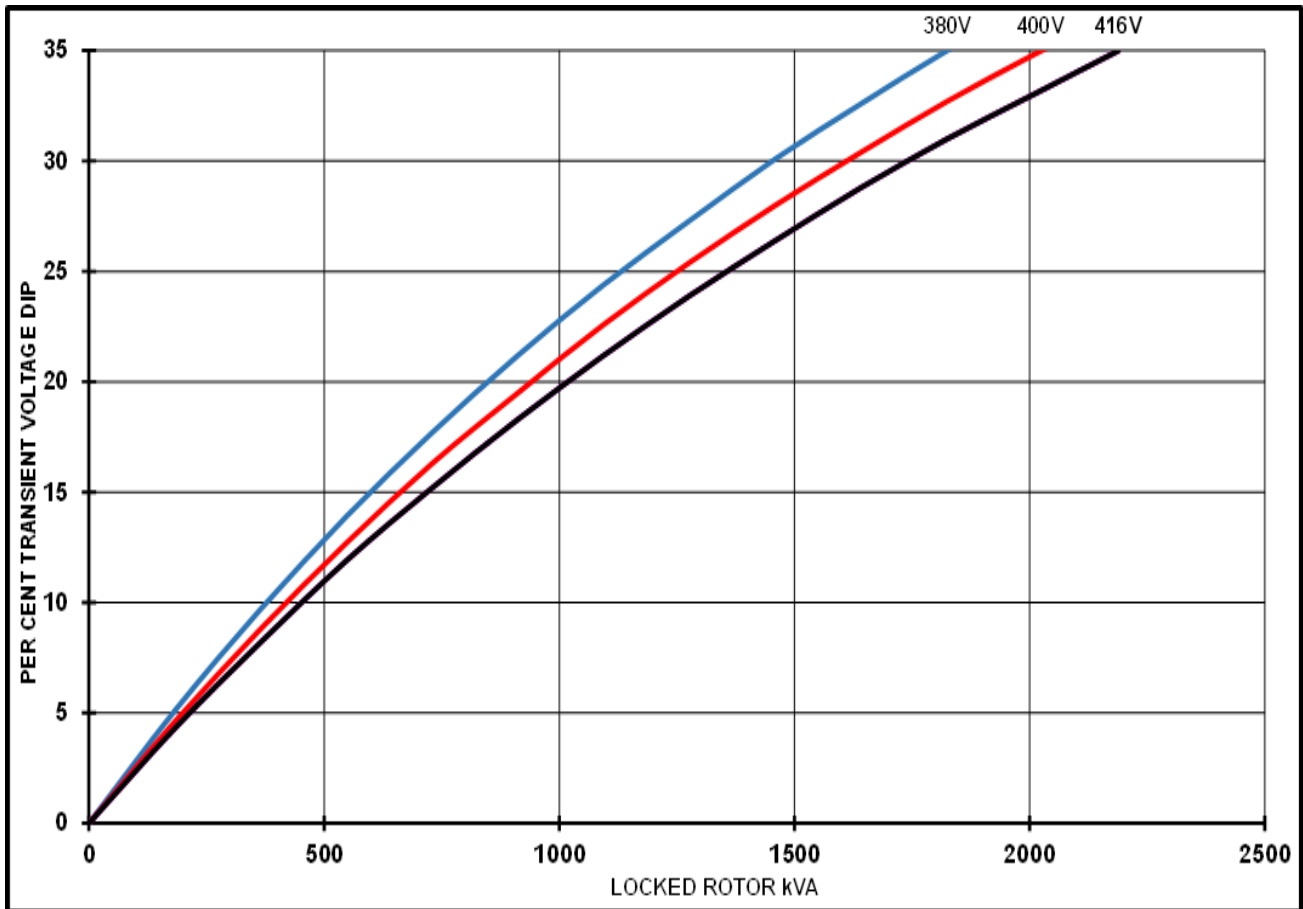

Transient Voltage Dip Scaling Factor		Transient Voltage Rise Scaling Factor
PF	Factor	
< 0.5	1	For voltage rise multiply voltage dip by 1.25
0.5	0.97	
0.6	0.93	
0.7	0.9	
0.8	0.85	
0.9	0.83	

# STAMFORD®

S4L1M-F41 Wdg.13

## Three-phase Short Circuit Decrement Curve

**60Hz**

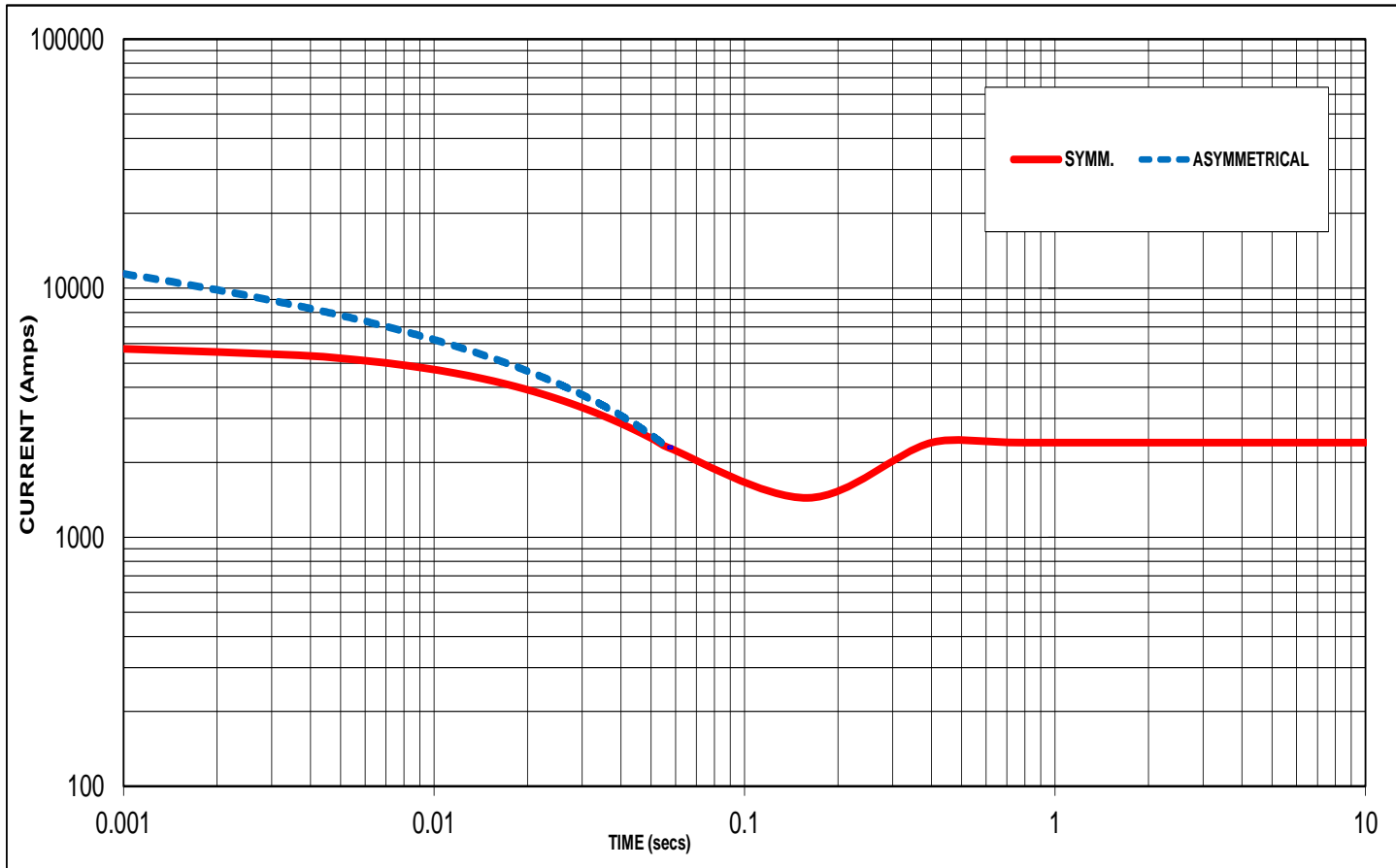

Sustained Short Circuit = 2400 Amps

### Note 1

The following multiplication factors should be used to adjust the values from curve between time 0.001 seconds and the minimum current point in respect of nominal operating voltage :

60Hz	
Voltage	Factor
380V	X 1.00
400V	X 1.05
416V	X 1.09

The sustained current value is constant irrespective of voltage level

### Note 2

The following multiplication factor should be used to convert the values calculated in accordance with NOTE 1 to those applicable to the various types of short circuit :

	3-phase	2-phase L-L	1-phase L-N
Instantaneous	x 1.00	x 0.87	x 1.30
Minimum	x 1.00	x 1.80	x 3.20
Sustained	x 1.00	x 1.50	x 2.50
Max. sustained duration	10 sec.	5 sec.	2 sec.

All other times are unchanged

### Note 3

Curves are drawn for Star connected machines under no-load excitation at rated speeds. For other connection the following multipliers should be applied to current values as shown :

Parallel Star = Curve current value X 2  
 Series Delta = Curve current value X 1.732

# STAMFORD®

## S4L1M-F41 Wdg.13

### Typical Alternator Operating Charts

**380V/60Hz**

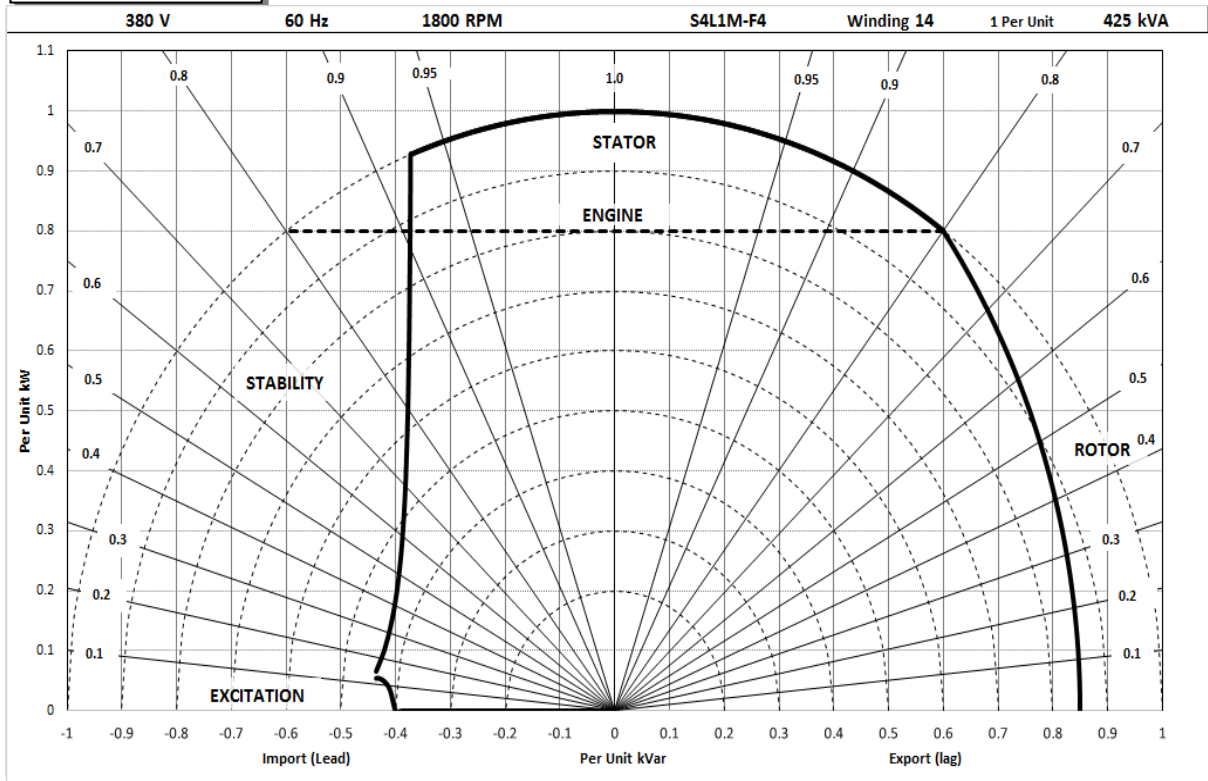

**416V/60Hz**

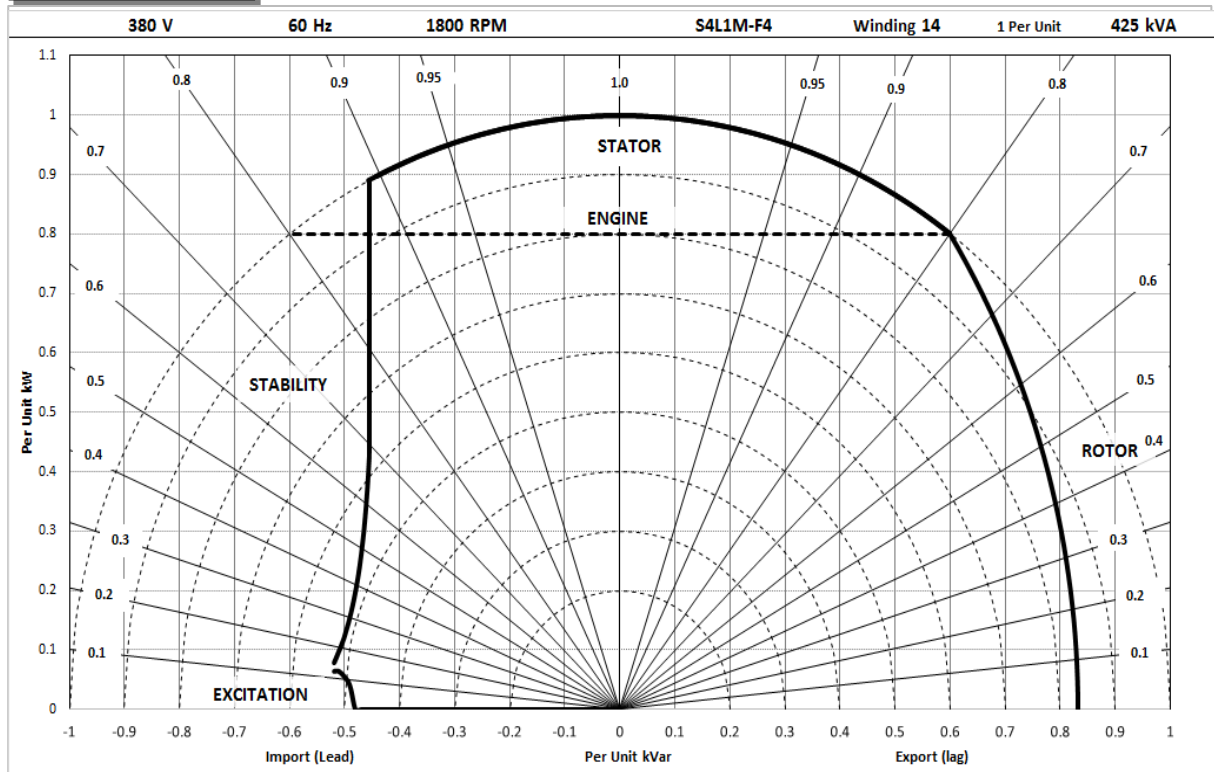

# STAMFORD®

S4L1M-F41 Wdg.13

## RATINGS AT 0.8 POWER FACTOR

Class - Temp Rise		Cont. H - 110/50°C			Cont. F - 90/50°C			Cont. B - 70/50°C		
<b>60</b> Hz	Series Star (V)	380	400	416	380	400	416	380	400	416
	kVA	425	425	425	395	395	395	345	345	345
	kW	340	340	340	316	316	316	276	276	276
	Efficiency (%)	93.8	94.0	94.1	94.0	94.2	94.2	94.3	94.3	94.3
	kW Input	362	362	361	336	335	335	293	293	293

### De-Rates

All values tabulated above are subject to the following reductions:

- 5% when air inlet filters are fitted
- 3% for every 500 meters by which the operating altitude exceeds 1000 meters above mean sea level
- 3% for every 5°C by which the operational ambient temperature exceeds 40°C
- For any other operating conditions impacting the cooling circuit please refer to applications

Note: Requirement for operating in an ambient exceeding 60°C and altitude exceeding 4000 meters must be referred to applications.

### Dimensional and Torsional Drawing

For dimensional and torsional information please refer to the alternator General Arrangement and rotor drawings available on our website (<http://stamford-avk.com/>)

**Note:** Continuous development of our products means that the information contained in our data sheets can change without notice, and specifications should always be confirmed with Cummins Generator Technologies prior to purchase.





Follow us @stamfordavk



Cummins Generator Technologies



View our videos at [youtube.com/stamfordavk](https://youtube.com/stamfordavk)

**[news.stamford-avk.com](https://news.stamford-avk.com)**

**For Applications Support:**  
**[applications@cummins.com](mailto:applications@cummins.com)**

**For Customer Service:**  
**[service-engineers@stamford-avk.com](mailto:service-engineers@stamford-avk.com)**

**For General Enquiries:**  
**[info@cumminsgeneratortechnologies.com](mailto:info@cumminsgeneratortechnologies.com)**

Copyright 2016. Cummins Generator Technologies Ltd. All rights reserved.  
Cummins and the Cummins logo are registered trade marks of Cummins Inc.  
STAMFORD is a registered trade mark of Cummins Generator Technologies Ltd.

