

DRG. SIZE C REL. PHASE P PART No L15-13176 ISSUE B

IF IN DOUBT-ASK
DO NOT SCALE

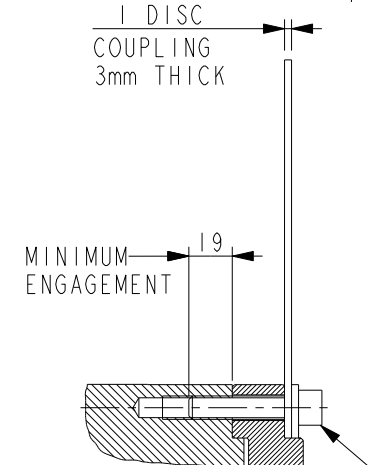
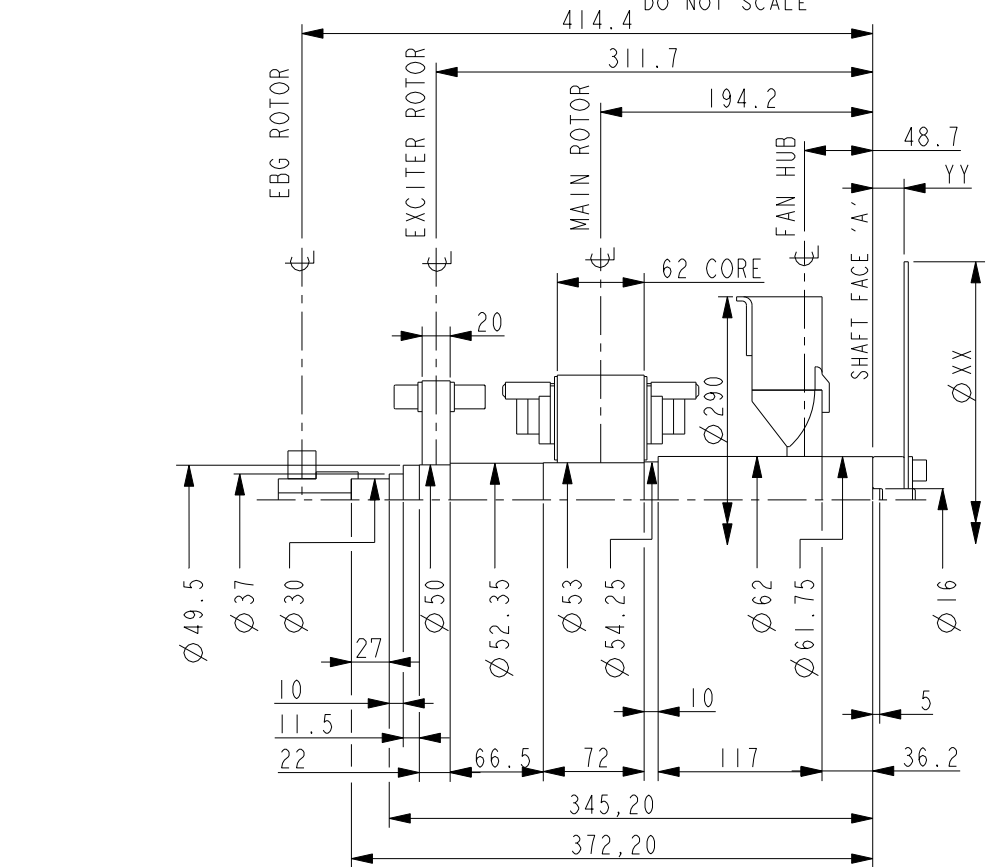

COMPONENT	MASS (kg)	WR ² (kgm ²)
SHAFT	6.936	0.0028
FAN	0.976	0.0067
MAIN ROTOR	13.207	0.0642
EXCITER ROTOR	3.495	0.0139
TOTAL WITHOUT EBG ROTOR	24.614	0.0876
EBG ROTOR	1.701	0.0017
TOTAL WITH EBG ROTOR	26.315	0.0893

CONVERSION FACTORS		
TO CONVERT	TO	DIVIDE BY
kg	lb	0.453592
kgm ²	lbf ft ²	0.04214
kgcm/rad	lbin/rad	1.1521246
N/m ²	lbf/in ²	6894.76

NOTES:-

SHAFT STIFFNESS:-
THE STIFFNESS OF THE SHAFT BETWEEN THE MAIN ROTOR CORE ϕ AND THE SHAFT FACE 'A' IS 5.0903×10^6 kgcm/radian (STIFFENING EFFECT OF MAIN ROTOR CORE IS NOT INCLUDED IN THIS FIGURE)

SHAFT MATERIAL:-
STEEL - C40E TO BSEN 10083-2 2006 (APPROVED BY MARINE AUTHORITIES WHEN APPROPRIATE)
MAXIMUM RECOMMENDED VIBRATORY STRESS LEVEL IN THE SHAFT IS 34.47×10^6 N/m² FOR SPEED RANGE OF 0.95 TO 1.1 X NOMINAL SPEED AND 68.94×10^6 N/m² FOR RUN THROUGH CONDITIONS, FOR INDUSTRIAL MACHINES.

FOR MARINE AUTHORITIES, THEIR APPROPRIATE RULES WILL APPLY.

CUMMINS GENERATOR TECHNOLOGIES LTD SHOULD BE NOTIFIED OF ANY ROTORS NOT COMPLYING WITH THESE RULES. CUMMINS GENERATOR TECHNOLOGIES LTD BALANCE ROTORS TO COMPLY WITH INTERNATIONAL STD BS ISO 1940 PARTS 1 AND 2 . BALANCE GRADE 2.5

FOR UNBALANCED MAGNETIC PULL (U.M.P.) REFER TO THE FACTORY.

ADAPTOR SAE No.	COUPLING SAE No.	COUPLING DIMENSIONS		MASS OF DISC (kg) (1 X 3mm THICK)	MASS OF SHAFT SPACER (kg)	MASS OF PRESSURE PLATE (kg)	TOTAL MASS OF COUPLING ASSEMBLY (kg)	COUPLING STIFFNESS (kgcm/rad)	COUPLING DISC WR ² (kgm ²)
		ϕ XX mm	YY mm						
4/5	6 1/2	215.8	10	0.850	0.233	0.069	1.152	13.955×10^6	0.0049
4/5	7 1/2	241.2	10	1.069	0.233	0.069	1.371	13.835×10^6	0.0079
3/4/5	8	263.5	41.8	1.275	0.974	0.069	2.318	13.747×10^6	0.0111
2/3/4	10	314.2	33.6	1.819	0.783	0.069	2.671	13.616×10^6	0.0225
2/3	11 1/2	352.3	19.4	2.287	0.452	0.069	2.808	13.555×10^6	0.0355

CONFIDENTIAL PROPERTY OF CUMMINS GENERATOR TECHNOLOGIES LTD.					
MATERIAL PROPS	-	DIMENSIONS IN MILLIMETRES (MM) AT 20°C	PROJECTION 		
FINISH SPEC	-				
GEOMETRY SPEC	-	SURFACE FINISH VALUES IN MICRO METRES	WEIGHT =		
ASSEMBLY SPEC	-				
PERFORMANCE SPEC	-	UNLIMITED DIMS ± --	DRAWN	BSR	25/04/07
QUALITY SPEC	-		CHECKED	DSG	29/08/09
			APPROVED	JB	29/08/09

P04D ONE BEARING MOMENTS OF INERTIA AND SHAFT DETAILS	
SCALE 3:10	MATERIAL --
DRG. SIZE C	CASTING No -
REL. PHASE P	PART No L15-13176
PRO/ENGINEER	ISSUE B
SHEET 1 OF 1 SHEETS	

MOD.	ISSUE	DRAWN	DATE	MODIFICATION
5-0223-09	B	DW	29/8/09	CHANGED SHAFT STIFFNESS FROM 5.4167 TO 5.0903
4-8440-50	A	BSR	25/04/07	ORIGINAL ISSUE