

DRG. SIZE C	REL. PHASE P	PART No 19-1037	ISSUE G
----------------	-----------------	--------------------	------------

IF IN DOUBT-ASK
DO NOT SCALE

DIMENSIONS					
FRAME	"A"	"B"	"C"	"D"	NETT WT. (Kg)
PI4H2	780	698	455	300	175.5
PI4J2	810	728	485	315	187
PI4K2	825	743	500	321	196

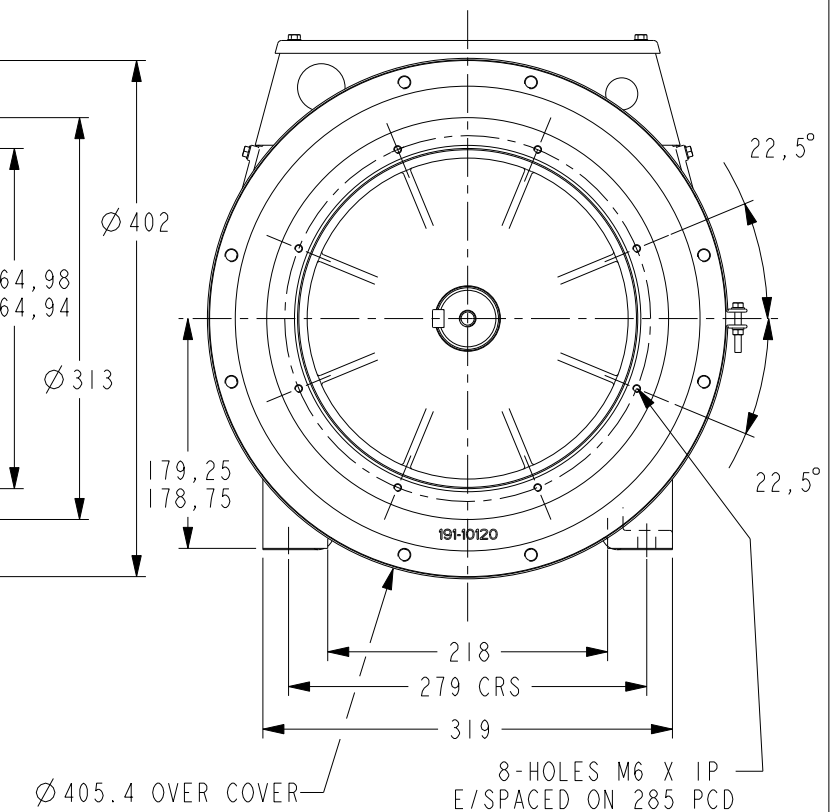
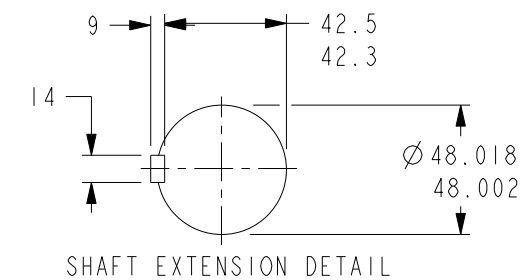
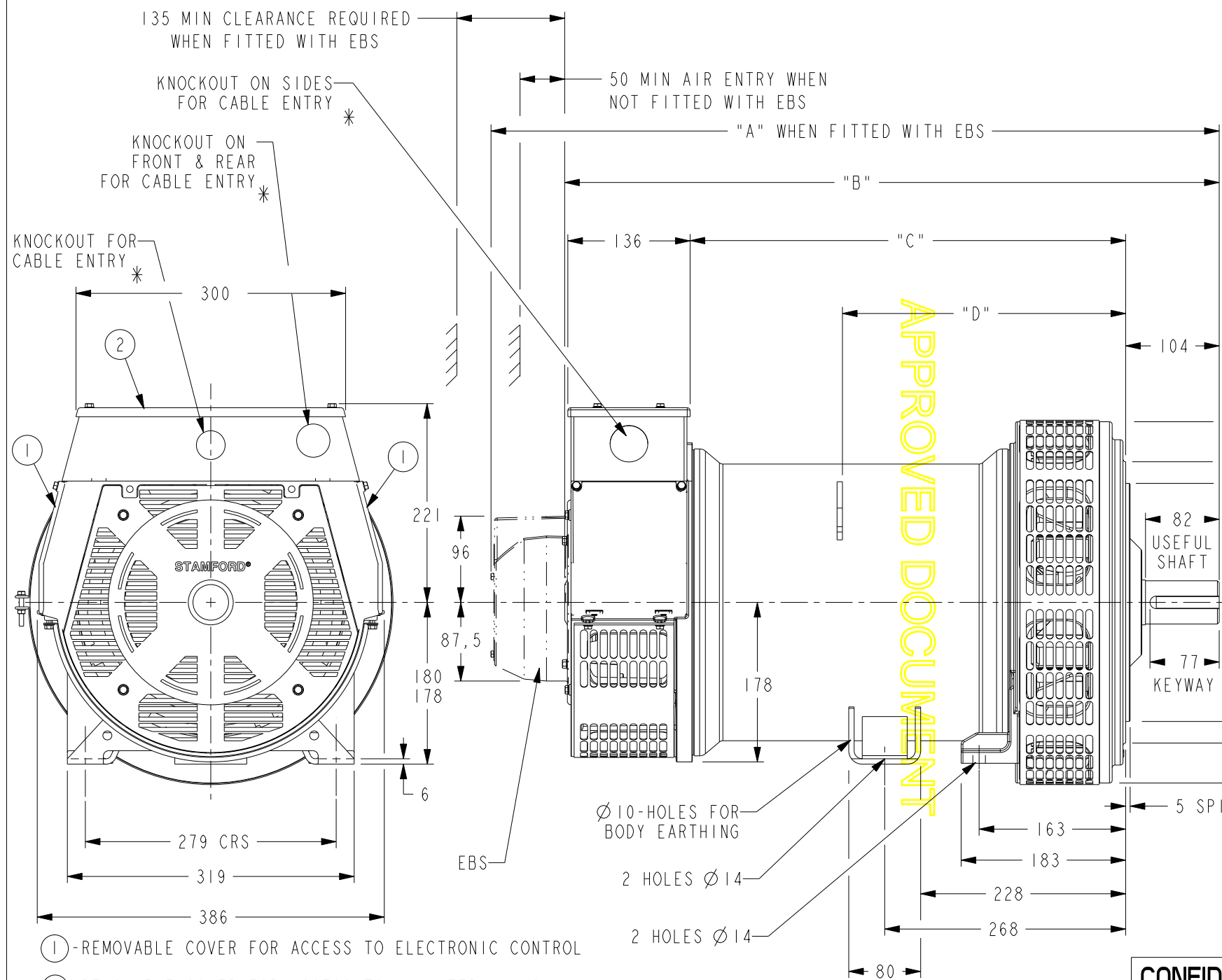

- ① - REMOVABLE COVER FOR ACCESS TO ELECTRONIC CONTROL
- ② - REMOVABLE COVER FOR ACCESS TO MAIN TERMINALS
- * FOR KNOCKOUT DETAILS REFER TERMINAL BOX DRAWING

APPROVED DOCUMENT

MOD.	ISSUE	DRAWN	DATE	MODIFICATION
5-0223-62	G	DW	22/6/10	REMOVED 2-POLE DESIGNATION (PI2H2 AND PI2J2) FROM TABLE
5-0223-51	F	SAB	29/03/10	TOLERANCE ADDED FOR CENTER HEIGHT.
4-9667-82	E	BJ	16:06:09	PRO-E DRG. CONVERTED TO DXF.
-	-	-	-	PREVIOUS MODS 4-8440-97 , 4-9111-10 , 4-9346-21 , 4-9346-54

CONFIDENTIAL PROPERTY OF
CUMMINS GENERATOR TECHNOLOGIES LTD.

DIMENSIONS IN MILLIMETRES
(MM) AT 20°C

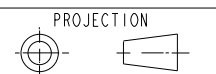

UNLIMITED DIMS ± --

DRAWN	BSR	21.06.07
CHECKED	DW	22/6/10
APPROVED	JB	22/6/10

PI H/J/K
4-POLE
2-BRG ALTERNATOR

DRG. SIZE C	SCALE 3:10
REL. PHASE P	PART No 19-1037
PRO/ENGINEER	ISSUE G
SHEET 1 OF 1 SHEETS	