

DL15-12571

ISSUE
A

IF IN DOUBT-ASK
DO NOT SCALE

FIRST W.O.

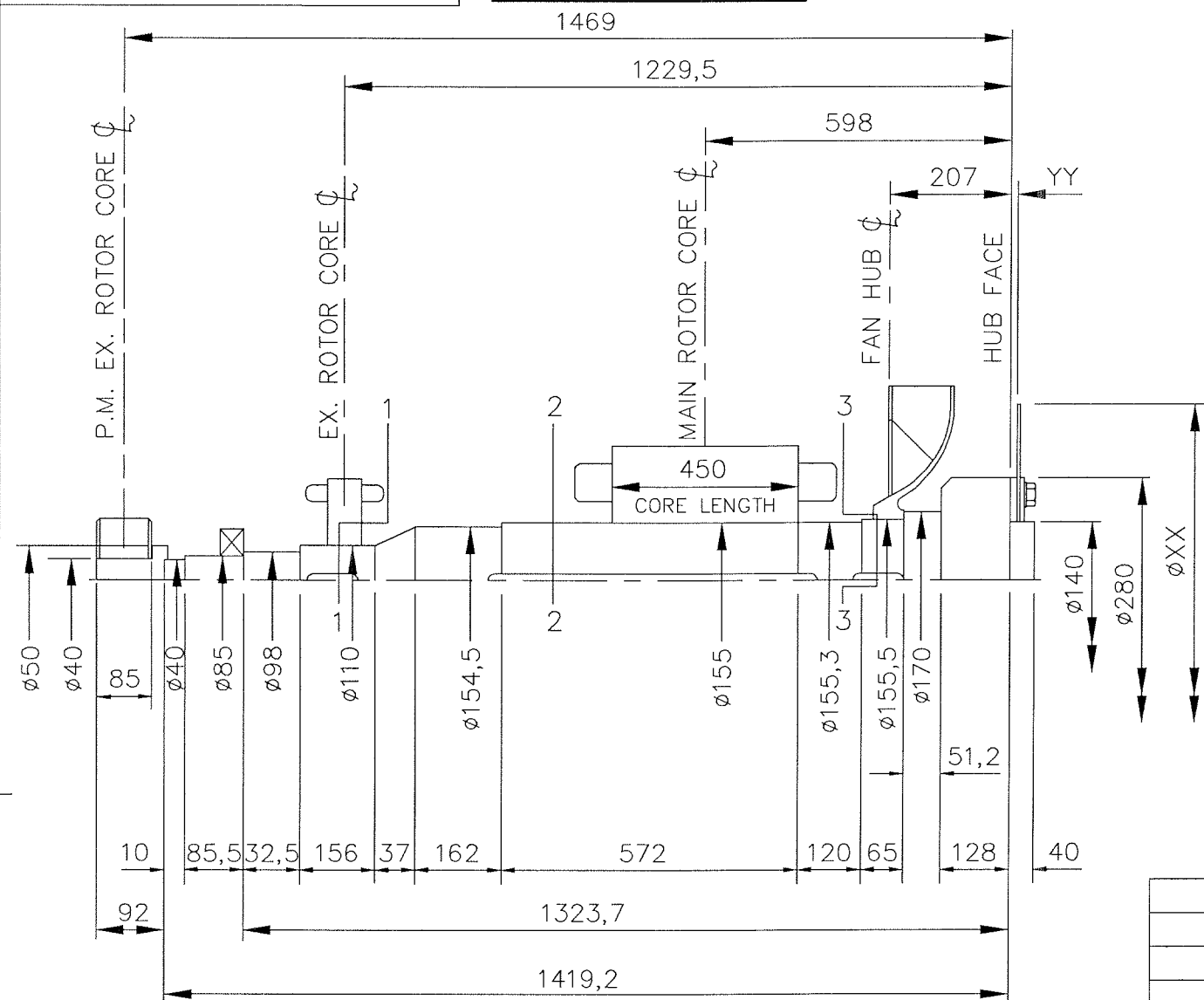

NOTES!

SHAFT STIFFNESS:-

THE STIFFNESS OF THE SHAFT BETWEEN THE MAIN ROTOR CORE ϕ AND THE COUPLING HUB FACE IS $99,20 \times 10^6$ kgcm/radian (STIFFENING EFFECT OF MAIN ROTOR CORE IS NOT INCLUDED IN THIS FIGURE)

SHAFT MATERIAL:-

STEEL - 080M40 TO BS970 PART 1 (APPROVED BY MARINE AUTHORITIES WHEN APPROPRIATE).

MAXIMUM RECOMMENDED VIBRATORY STRESS LEVEL IN THE SHAFT IS $34,47 \times 10^6$ N/m² FOR A SPEED RANGE OF 0,95 TO 1,1 x NOMINAL SPEED, AND $68,94 \times 10^6$ N/m² FOR RUN THROUGH CONDITIONS, FOR INDUSTRIAL MACHINES. FOR MARINE AUTHORITIES, THEIR APPROPRIATE RULES WILL APPLY.

NEWAGE INTERNATIONAL LTD. SHOULD BE NOTIFIED OF ANY ROTORS NOT COMPLYING WITH THESE RULES.

NEWAGE INTERNATIONAL LTD. BALANCE ROTORS TO COMPLY WITH INTERNATIONAL STD. I.S.O. 1940 GRADE 2,5 AND B.S. 6861 PART 1 GRADE 2,5 .

FOR UNBALANCED MAGNETIC PULL (U.M.P.) FORCES REFER TO GENERATOR MANUAL.

SECTION THRO' SHAFT END AND COUPLING SCREWS OR BOLTS

MINIMUM 43 ENGAGEMENT

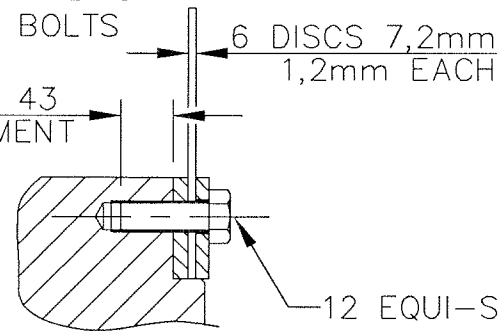

12 EQUI-SPACED SCREWS OR BOLTS M24 x 3 PITCH ON 230 P.C.D.

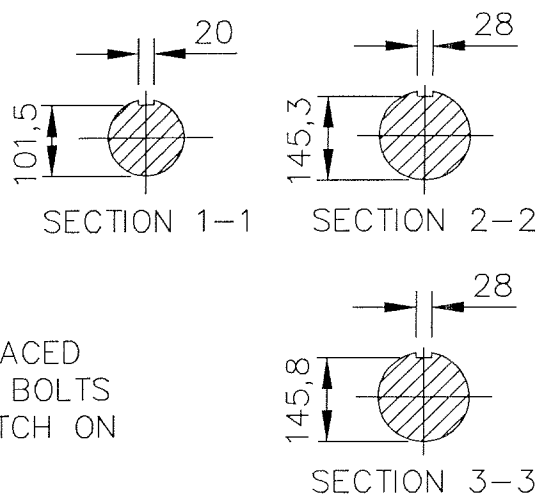

COMPONENT	Wt kg	WR ² kgm ²	COUPLING SAE No	COUPLING DIMEN'S		COUPLING ASSEMBLY WEIGHT kg	COUPLING STIFFNESS 6-PLATES kgcm/rad	COUPLING DISC WR ² kg m ²
				XX	YY			
EX. ROTOR	51,600	0,8590						
MAIN ROTOR	561,892	17,4556						
FAN	16,100	0,6762						
SHAFT	191,901	0,5514	14	467	25	25	$1395,6 \times 10^6$	0,265
HUB	37,098	0,4823	16	518	16	24,3	$1296,5 \times 10^6$	0,403
P.M. EX. ROTOR	6,970	0,0190	18	572	16	24,40	$1211,3 \times 10^6$	0,535
P.M. STUB SHAFT	0,929	0,0003	21	673	00	24,25	$1140,7 \times 10^6$	1,053
			17 ^{3/4}	451	18,2	24,75	$1534,8 \times 10^6$	0,230
			24	733	00	28,00	$1064,8 \times 10^6$	1,602
TOTAL	866,490	20,0438	24 Spec	733	28,5	38,30	$1064,8 \times 10^6$	1,602

CONVERSION FACTORS		
TO CONVERT	TO	DIVIDE BY
kg	lb	0,453592
kg m ²	lb ft ²	0,04214
kgcm/rad	lbin/rad	1,1521246
N/m ²	lbf/in ²	6894,76

CERTIFIED PRINT (ONLY IF SIGNED)		
BY		
DATE		
DRAWN	S.M.C.	29.06.00
CH'D	S.M.C.	17.7.00
APP'D		17/7/00

HC634 1H
MOMENTS OF INERTIA
AND SHAFT DETAILS

NEWAGE INTERNATIONAL LTD
STAMFORD ENGLAND

SCALE	FIRST W.O.
NTS	
SHEET 1:10	UNIT OF MEASUREMENT MILLIMETRES (mm)
DL15-12571	ISSUE A

4/3000/2	A	S.M.C.	29.06.00	ORIGINAL ISSUE
MOD'N	ISSUE	DRAWN	DATE	ALTERATION