

DL15-12581

ISSUE
A

IF IN DOUBT-ASK
DO NOT SCALE

FIRST W.O.

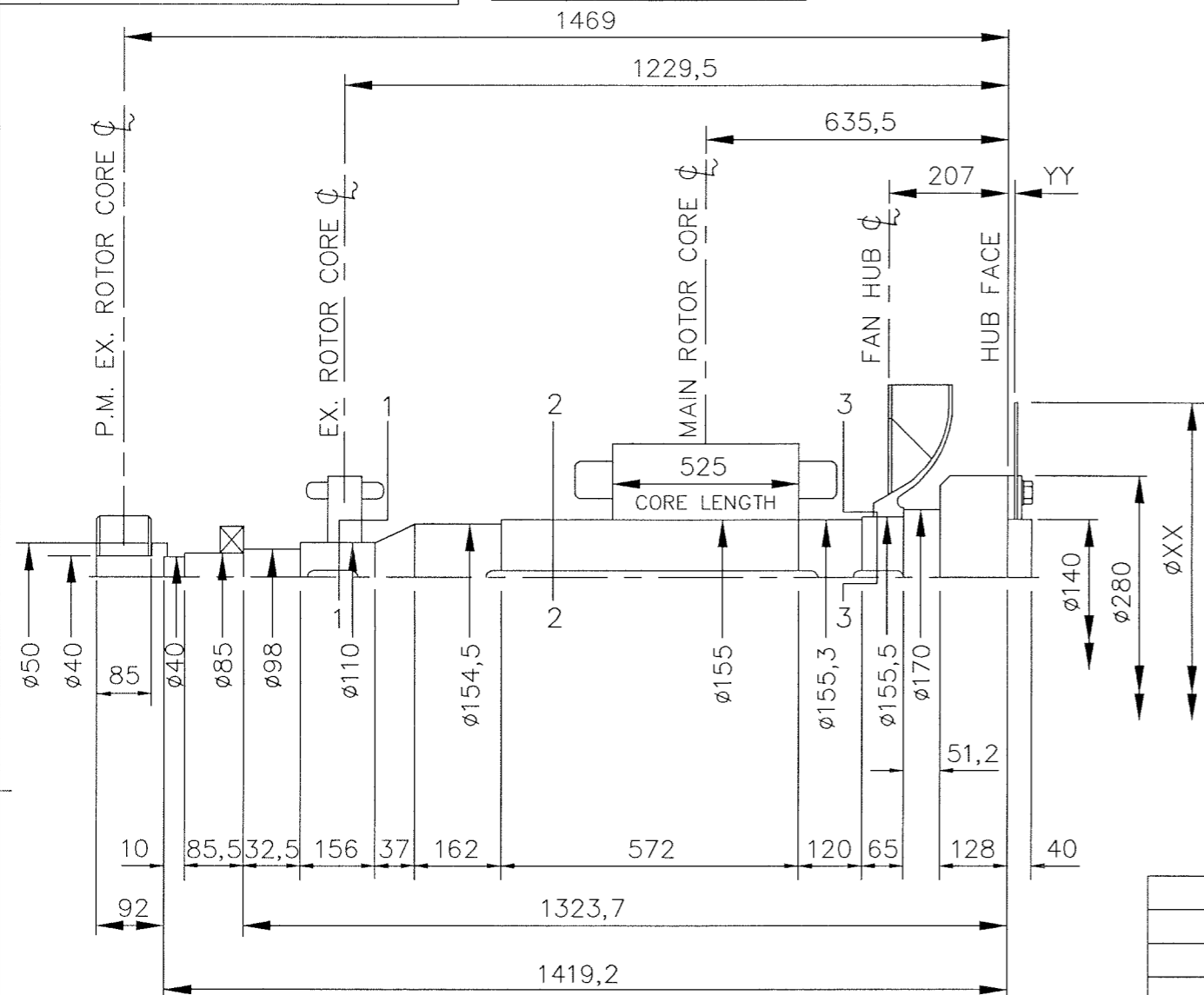

NOTES!
SHAFT STIFFNESS: -
THE STIFFNESS OF THE SHAFT BETWEEN THE MAIN ROTOR CORE ϕ AND THE COUPLING HUB FACE IS $91,69 \times 10^6$ kgcm/radian (STIFFENING EFFECT OF MAIN ROTOR CORE IS NOT INCLUDED IN THIS FIGURE)
SHAFT MATERIAL :-
STEEL - 080M40 TO BS970 PART 1 (APPROVED BY MARINE AUTHORITIES WHEN APPROPRIATE).
MAXIMUM RECOMMENDED VIBRATORY STRESS LEVEL IN THE SHAFT IS $34,47 \times 10^6$ N/m² FOR A SPEED RANGE OF 0,95 TO 1,1 x NOMINAL SPEED, AND $68,94 \times 10^6$ N/m² FOR RUN THROUGH CONDITIONS, FOR INDUSTRIAL MACHINES. FOR MARINE AUTHORITIES, THEIR APPROPRIATE RULES WILL APPLY.
NEWAGE INTERNATIONAL LTD. SHOULD BE NOTIFIED OF ANY ROTORS NOT COMPLYING WITH THESE RULES.
NEWAGE INTERNATIONAL LTD. BALANCE ROTORS TO COMPLY WITH INTERNATIONAL STD. I.S.O. 1940 GRADE 2,5 AND B.S. 6861 PART 1 GRADE 2,5 .
FOR UNBALANCED MAGNETIC PULL (U.M.P.) FORCES REFER TO GENERATOR MANUAL.

SECTION THRO' SHAFT END AND COUPLING SCREWS OR BOLTS

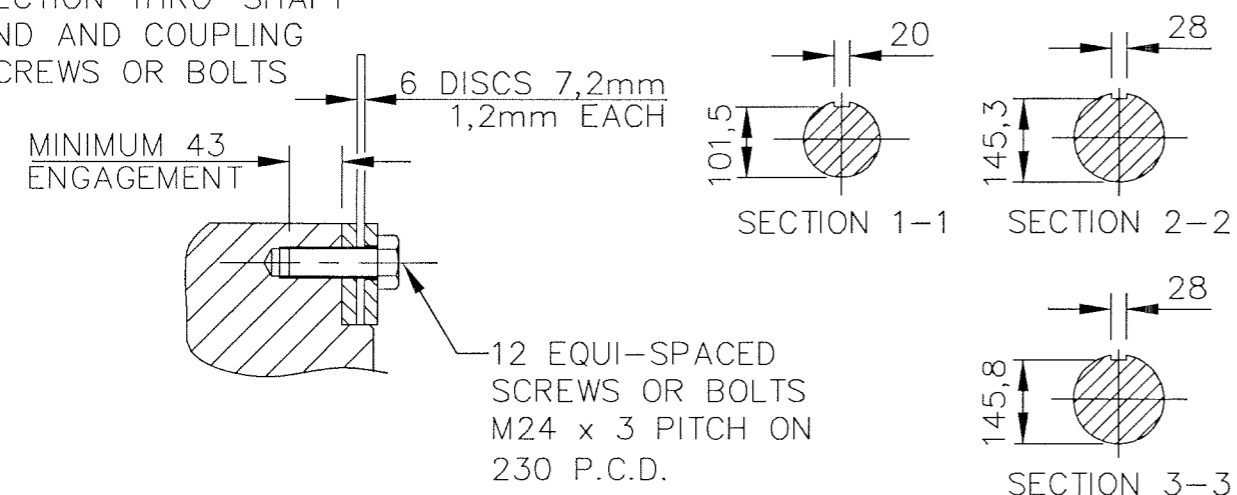

COMPONENT	Wt kg	WR ² kgm ²	COUPLING SAE No	COUPLING DIMEN's		COUPLING ASSEMBLY WEIGHT kg	COUPLING STIFFNESS 6-PLATES kgcm/rad	COUPLING DISC WR ² kg m ²
				XX	YY			
EX. ROTOR	51,600	0,8590						
MAIN ROTOR	720,300	25,1932						
FAN	16,100	0,6762						
SHAFT	191,923	0,5514	14	467	25	25	$1395,6 \times 10^6$	0,265
HUB	37,098	0,4823	16	518	16	24,3	$1296,5 \times 10^6$	0,403
P.M. EX. ROTOR	6,970	0,0190	18	572	16	24,40	$1211,3 \times 10^6$	0,535
P.M. STUB SHAFT	0,929	0,0003	21	673	00	24,25	$1140,7 \times 10^6$	1,053
			17 ^{3/4}	451	18,2	24,75	$1534,8 \times 10^6$	0,230
			24	733	00	28,00	$1064,8 \times 10^6$	1,602
			24 Spec	733	28,5	38,30	$1064,8 \times 10^6$	1,602
TOTAL	1024,920	27,7814						

4/3000/2	A	S.M.C.	13.07.00	ORIGINAL ISSUE	CERTIFIED PRINT (ONLY IF SIGNED)		HC636 1K MOMENTS OF INERTIA AND SHAFT DETAILS		SCALE	FIRST W.O.
MOD'N	ISSUE	DRAWN	DATE	ALTERATION	DATE		NEWAGE INTERNATIONAL LTD STAMFORD ENGLAND		NTS SHEET 1:10	UNIT OF MEASUREMENT MILLIMETRES (mm)
CONVERSION FACTORS				BY		S.M.C. 13.07.00		DL15-12581		ISSUE
TO CONVERT	TO	DIVIDE BY	DATE		S.M.C. 17.7.00		STAMFORD ENGLAND		A	
kg	lb	0,453592	13.07.00		17.7.00					
kg m ²	lb ft ²	0,04214								
kgcm/rad	lbin/rad	1,1521246								
N/m ²	lbf/in ²	6894,76								