

SECTION THRO' SHAFT  
END AND COUPLING  
SCREWS OR BOLTS

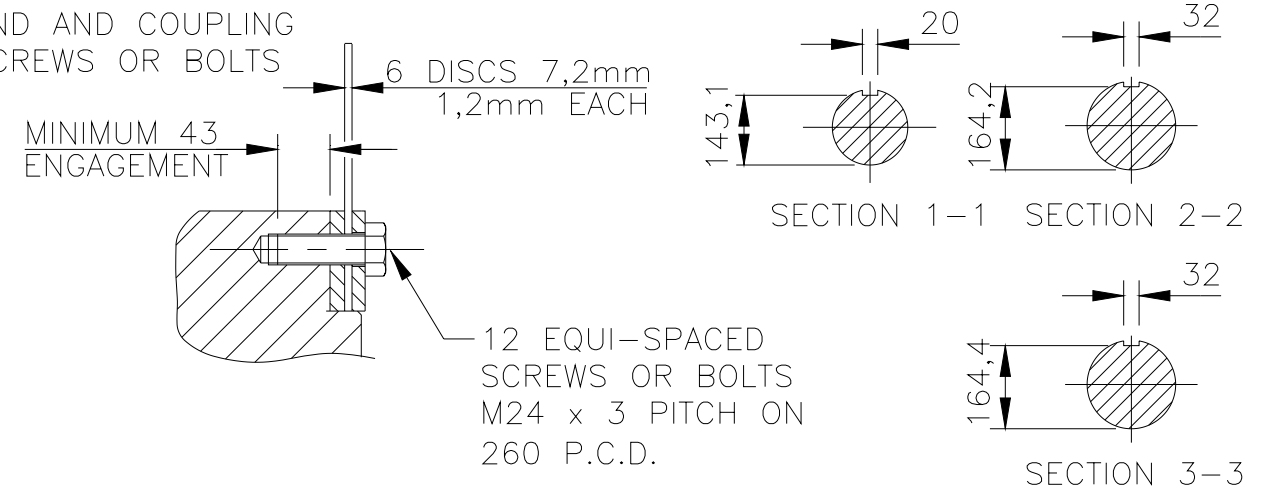

APPROVED DOCUMENT

NOTES:  
SHAFT STIFFNESS:-  
THE STIFFNESS OF THE SHAFT BETWEEN THE MAIN ROTOR CORE  $\phi$   
AND THE COUPLING HUB FACE IS  $121,79 \times 10^6$  kgcm/radian  
(STIFFENING EFFECT OF MAIN ROTOR CORE IS NOT INCLUDED IN THIS FIGURE)

SHAFT MATERIAL:-  
STEEL - 080M40 TO BS970 PART 1 (APPROVED BY MARINE AUTHORITIES  
WHEN APPROPRIATE).  
MAXIMUM RECOMMENDED VIBRATORY STRESS LEVEL IN THE SHAFT IS  
 $34,47 \times 10^6$  N/m<sup>2</sup> FOR A SPEED RANGE OF 0,95 TO 1,1 x NOMINAL SPEED, AND  
 $68,94 \times 10^6$  N/m<sup>2</sup> FOR RUN THROUGH CONDITIONS, FOR INDUSTRIAL MACHINES.  
FOR MARINE AUTHORITIES, THEIR APPROPRIATE RULES WILL APPLY.  
CUMMINS GENERATOR TECHNOLOGIES LTD. SHOULD BE NOTIFIED OF ANY ROTORS  
NOT COMPLYING WITH THESE RULES.  
CUMMINS GENERATOR TECHNOLOGIES LTD. BALANCE ROTORS TO COMPLY WITH  
INTERNATIONAL STD. I.S.O. 1940 GRADE 2,5 AND B.S. 6861 PART 1 GRADE 2,5 .  
FOR UNBALANCED MAGNETIC PULL (U.M.P.) FORCES REFER TO GENERATOR MANUAL.

COMPONENT	Wt kg	WR <sup>2</sup> kgm <sup>2</sup>	COUPLING SAE No	COUPLING DIMEN's XX YY	COUPLING ASSEMBLY WEIGHT kg	COUPLING STIFFNESS 6-PLATES kgcm/rad	COUPLING DISC WR <sup>2</sup> kg m <sup>2</sup>
EX.ROTOR	46,791	0,7758					
MAIN ROTOR	1056,084	41,0301					
FAN	28,800	1,6520					
SHAFT	301,114	1,1282	18	572 16	24,5	$1592 \times 10^6$	0,590
HUB	53,533	0,8846	21	673 00	23,1	$1468 \times 10^6$	1,135
P.MAG.ROTOR	6,970	0,0190	24	733 00	26,84	$1428 \times 10^6$	1,598
STUB SHAFT	0,929	0,0003					
-	-	-					
TOTAL	1494,221	45,4900					

CONVERSION FACTORS		
TO CONVERT	TO	DIVIDE BY
kg	lb	0,453592
kg m <sup>2</sup>	lb ft <sup>2</sup>	0,04214
kgcm/rad	lbin/rad	1,1521246
N/m <sup>2</sup>	lbf/in <sup>2</sup>	6894,76

MOD'N	ISSUE	DRAWN	DATE	ALTERATION
5-0448-02	C	TW	04.05.10	CHANGE OF COMPANY NAME AND CORRECTION TO DOUBLE ISSUE
4/6904/1	B	DW	22.09.03	EX ROTOR MTG ø110, MOD WEIGHT AND INERTIA AND SHAFT, E/ROTOR & TOTAL
4/6745/9	A	SMC	08.07.03	ORIGINAL ISSUE

CERTIFIED PRINT (ONLY IF SIGNED)		
BY		
DATE		
DRAWN	SMC	08.07.03
CHECK	AJB	04.05.10
APPR'D	JKB	04.05.10

P7E SINGLE BEARING  
MOMENTS OF INERTIA  
AND SHAFT DETAILS

CUMMINS GENERATOR  
TECHNOLOGIES LTD.

SCALE NTS (SHEET 1:10)	FIRST W.O.
	UNIT OF MEASUREMENT MILLIMETRES (mm)
DL15-12898 C	ISSUE