

NOTES:-

SHAFT STIFFNESS:-

THE STIFFNESS OF THE SHAFT BETWEEN THE MAIN ROTOR CORE ϕ AND THE SHAFT FACE 'A' IS 2.6860×10^6 kgcm/radian (STIFFENING EFFECT OF MAIN ROTOR CORE IS NOT INCLUDED IN THIS FIGURE)

SHAFT MATERIAL:-

STEEL - C40E TO BSEN 10083-2 2006 (APPROVED BY MARINE AUTHORITIES WHEN APPROPRIATE)
MAXIMUM RECOMMENDED VIBRATORY STRESS LEVEL IN THE SHAFT IS 34.47×10^6 N/m² FOR SPEED RANGE OF 0.95 TO 1.1 X NOMINAL SPEED AND 68.94×10^6 N/m² FOR RUN THROUGH CONDITIONS, FOR INDUSTRIAL MACHINES.

FOR MARINE AUTHORITIES, THEIR APPROPRIATE RULES WILL APPLY.

CUMMINS GENERATOR TECHNOLOGIES LTD SHOULD BE NOTIFIED OF ANY ROTORS NOT COMPLYING WITH THESE RULES. CUMMINS GENERATOR TECHNOLOGIES LTD BALANCE ROTORS TO COMPLY WITH INTERNATIONAL STD BS ISO 1940 PARTS 1 AND 2 . BALANCE GRADE 2.5

FOR UNBALANCED MAGNETIC PULL (U.M.P.) REFER BACK TO THE FACTORY.

APPROVED DOCUMENT

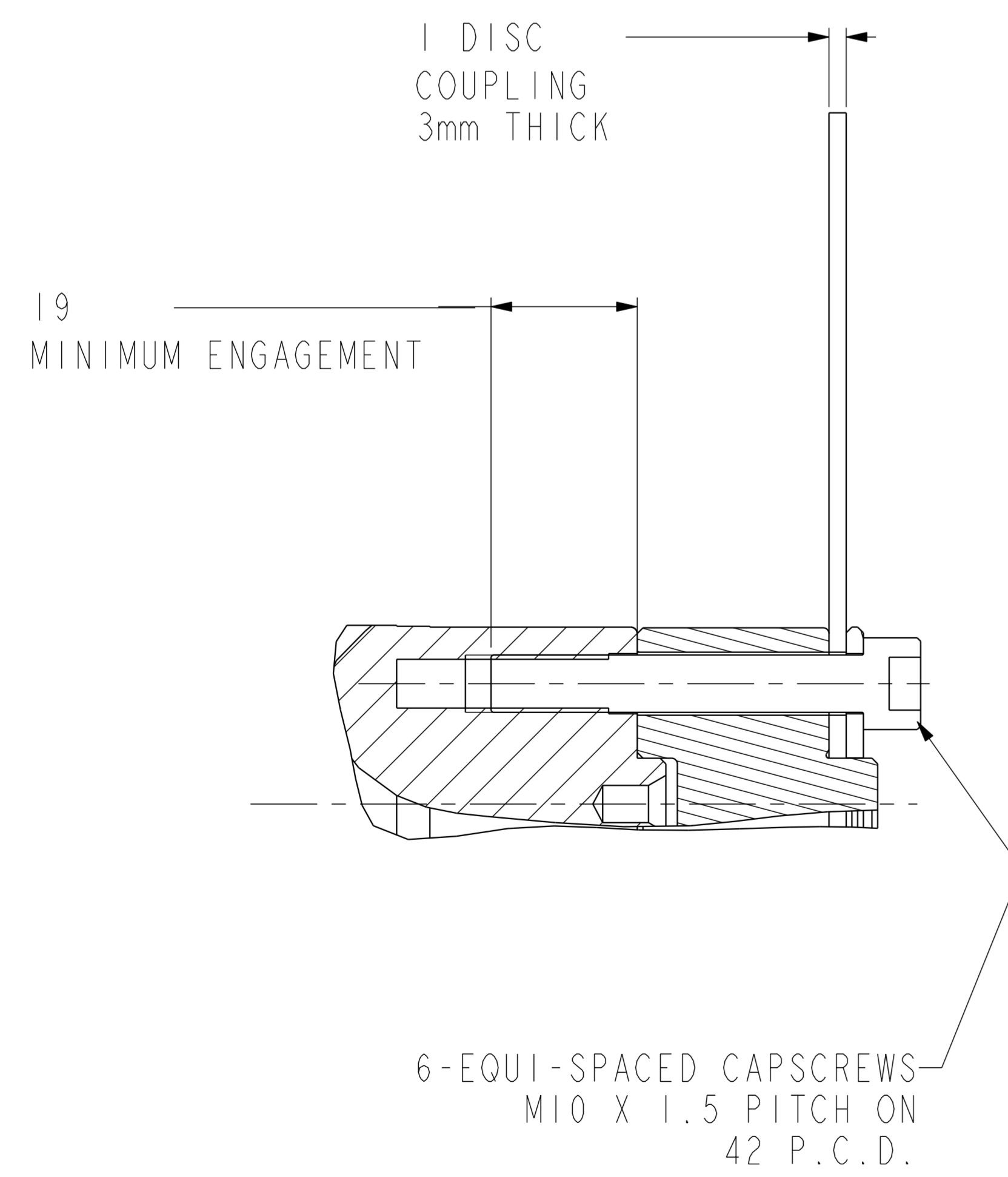

COMPONENT	MASS (kg)	WR ² (kgm ²)
SHAFT	8.274	0.0030
FAN	0.976	0.0067
MAIN ROTOR	24.934	0.0877
EXCITER ROTOR	5.120	0.0201
TOTAL WITHOUT EBG ROTOR	39.304	0.1175
EBG ROTOR	1.701	0.0017
TOTAL WITH EBG ROTOR	41.005	0.1192

ADAPTOR SAE No.	COUPLING SAE No.	COUPLING DIMENSIONS		MASS OF DISC (kg) (1 X 3mm THICK)	MASS OF SHAFT SPACER (kg)	MASS OF PRESSURE PLATE (kg)	TOTAL MASS OF COUPLING ASSEMBLY (kg)	COUPLING STIFFNESS (kgcm/rad)	COUPLING DISC WR ² (kgm ²)
		ϕ XX mm	YY mm						
4/5	6 1/2	215.8	10	0.850	0.233	0.069	1.152	13.955×10^6	0.0049
4/5	7 1/2	241.2	10	1.069	0.233	0.069	1.371	13.835×10^6	0.0079
4/5	8	263.5	41.8	1.275	0.974	0.069	2.318	13.747×10^6	0.0111
3/4	10	314.2	33.6	1.819	0.783	0.069	2.671	13.616×10^6	0.0225
3	11 1/2	352.3	19.4	2.287	0.452	0.069	2.808	13.555×10^6	0.0355

CONVERSION FACTORS		
TO CONVERT	TO	DIVIDE BY
kg	lb	0.453592
kgm ²	lbf ²	0.04214
kgcm/rad	lbin/rad	1.1521246
N/m ²	lbf/in ²	6894.76

MOD.	ISSUE	DRAWN	DATE	MODIFICATION
4-9111-12	A	SMJ	06.07.07	ORIGINAL ISSUE

CONFIDENTIAL PROPERTY OF CUMMINS GENERATOR TECHNOLOGIES LTD.				P12F ONE BEARING MOMENTS OF INERTIA AND SHAFT DETAILS												
MATERIAL PROPS	-	DIMENSIONS IN MILLIMETRES (MM) AT 20°C	PROJECTION	SCALE	3:10	MATERIAL	-									
FINISH SPEC	-	SURFACE FINISH VALUES IN MICRO METRES		DRG. SIZE	A	CASTING No.	-									
GEOMETRY SPEC	-			WEIGHT	=	PART No.	L15-13223	ISSUE	A							
ASSEMBLY SPEC	-	UNLIMITED DIMS \pm	<table border="1"> <tr> <td>DRAWN</td> <td>SMJ</td> <td>06.07.07</td> </tr> <tr> <td>CHECKED</td> <td>RPM</td> <td>10.07.07</td> </tr> <tr> <td>APPROVED</td> <td>DPC</td> <td>11.07.07</td> </tr> </table>	DRAWN	SMJ	06.07.07	CHECKED	RPM	10.07.07	APPROVED	DPC	11.07.07	REL. PHASE	P	SHEET	1 OF 1 SHEETS
DRAWN	SMJ	06.07.07														
CHECKED	RPM	10.07.07														
APPROVED	DPC	11.07.07														
PERFORMANCE SPEC	-			Proj/ENGINEER												
QUALITY SPEC	-															