

**STAMFORD®**

PG80 Alternators  
**OWNER MANUAL**

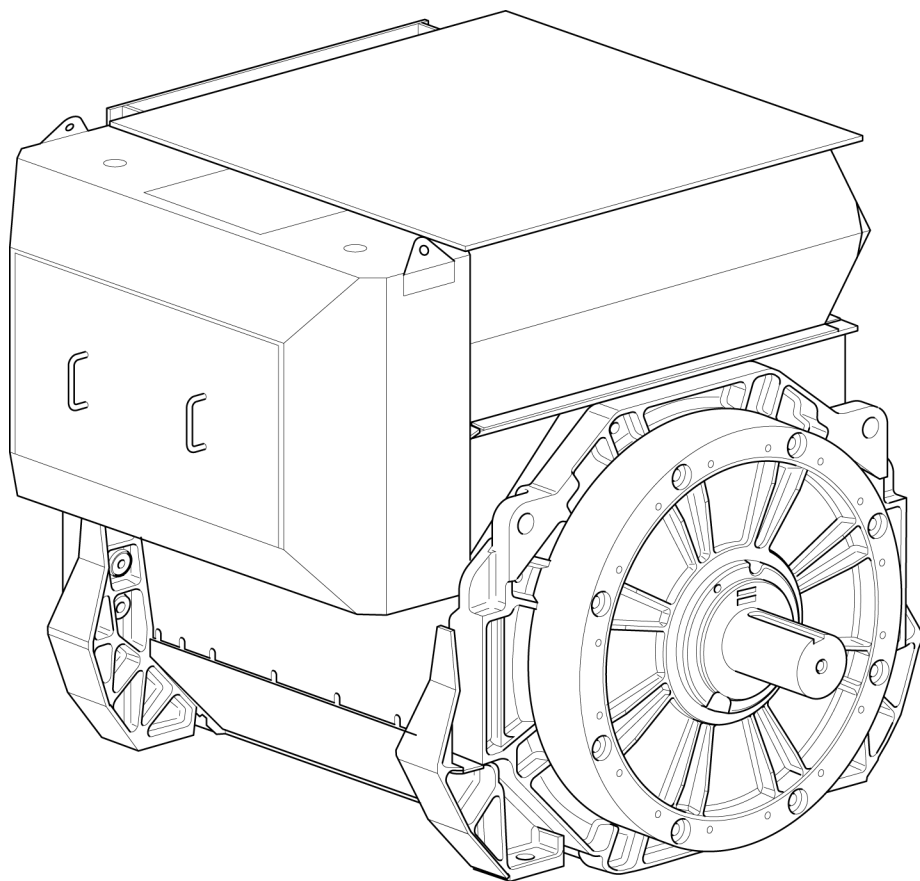



# Table of Contents

---

1. FOREWORD .....	1
2. SAFETY PRECAUTIONS.....	3
3. SAFETY DIRECTIVES AND STANDARDS .....	7
4. INTRODUCTION .....	11
5. APPLICATION OF THE ALTERNATOR .....	15
6. INSTALLATION INTO THE GENERATOR SET .....	21
7. SERVICE AND MAINTENANCE.....	31
8. PARTS IDENTIFICATION.....	57
9. TECHNICAL DATA.....	65
10. SERVICE PARTS AND AFTER SALES SERVICE.....	71
11. END OF LIFE DISPOSAL .....	73

---

This page is intentionally blank.

# 1 Foreword

---

## 1.1 The Manual

This manual contains guidance and instructions for the installation and operation of the alternator. The alternator is optimised for incorporating into a generator set certified as Grid Code Compliant. This manual does not include instructions for servicing and maintaining the alternator. Contact CGT Customer Service for details.

Before operating the alternator, read this manual and make sure that all personnel who work on the equipment have access to the manual and all additional documentation supplied with it. Misuse and failure to follow the instructions, and the use of non-approved parts, may invalidate the product warranty and lead to potential accidents.

This manual is an essential part of the alternator. Make sure that the manual is available to all users throughout the life of the alternator.

The manual is written for skilled electrical and mechanical technicians and engineers, who have prior knowledge and experience of generating equipment of this type. If in doubt, please seek expert advice or contact your local Cummins Generator Technologies subsidiary.

### **NOTICE**

Information in this manual was correct when published. It may be superseded due to our policy of continuous improvement. Please visit [www.stamford-avk.com](http://www.stamford-avk.com) for latest documentation.

-

---

This page is intentionally blank.

## 2 Safety Precautions

---

### 2.1 Safety Information and Notices used in this manual

Danger, Warning and Caution panels are used in this manual to describe the sources of hazards, their consequences and how to avoid injury. Notice panels emphasize important or critical instructions.

 <b>DANGER</b>
Danger indicates a hazardous situation which, if not avoided, <b>WILL</b> result in death or serious injury.

 <b>WARNING</b>
Warning indicates a hazardous situation which, if not avoided, <b>COULD</b> result in death or serious injury.

 <b>CAUTION</b>
Caution indicates a hazardous situation which, if not avoided, <b>COULD</b> result in minor or moderate injury.

<b>NOTICE</b>
Notice refers to a method or practice which can result in product damage, or to draw attention to additional information or explanations.

### 2.2 General Guidance

<b>NOTICE</b>
These safety precautions are for general guidance and supplement your own safety procedures and all applicable laws and standards.

### 2.3 Skill Requirements of Personnel

Service and maintenance procedures must only be carried out by experienced and qualified engineers, who are familiar with the procedures and the equipment.

### 2.4 Risk Assessment

A risk assessment has been performed on this product by Cummins, however a separate risk assessment must be performed by the user/operating company to establish all personnel-related risks. All affected users must be trained on the identified risks. Access to the Power Plant/Generator Set during operation must be restricted to persons who have been trained on these risks.

---

## 2.5 Personal Protective Equipment (PPE)

All persons operating, servicing, maintaining or working in or with a power plant or a generator set must wear appropriate Personal Protective Equipment (PPE)

Recommended PPE includes:

- Ear and Eye Protection
- Head and face protection
- Safety footwear
- Overalls that protect the lower arms and legs

Ensure that all persons are fully aware of the emergency procedures in case of accidents.

## 2.6 Noise

 **WARNING**

**Noise**

**Noise from a running alternator can cause serious injury by permanent hearing damage. To prevent injury, wear appropriate personal protection equipment (PPE).**

Maximum A-weighted noise emissions may reach 110 dB(A). Contact the supplier for application-specific details.

## 2.7 Electrical Equipment

 **DANGER**

**Live Electrical Conductors**

**Live electrical conductors can cause serious injury or death by electric shock and burns. To prevent injury and before removing covers over electrical conductors, isolate the generator set from all energy sources, remove stored energy and use lock out/tag out safety procedures.**

All electrical equipment can be dangerous if not operated correctly. Always install, service and maintain the alternator in accordance with this manual. Work that requires access to electrical conductors must comply with all applicable local and national electrical safety procedures for the voltages involved and any site specific rules. Always use genuine branded replacement parts.

## 2.8 Lock Out/Tag Out

 **WARNING**

**Reconnected Energy Source**

**Accidental reconnection of energy sources during service and maintenance work can cause serious injury or death by electric shock, burns, crushing, severing or trapping. To prevent injury and before starting service and maintenance work, use appropriate lock out/tag out safety procedures to keep the generator set isolated from energy sources. Do not defeat or bypass the lock out/tag out safety procedures.**



---

## 2.9 Lifting

### DANGER

#### Falling Mechanical Parts

Falling mechanical parts can cause serious injury or death by impact, crushing, severing or trapping.

To prevent injury and before lifting:

- Check the capacity, condition and attachment of lifting equipment (crane, hoists and jacks, including attachments to anchor, fix or support the equipment).
- Check the capacity, condition and attachment of accessories for lifting (hooks, slings, shackles and eye bolts for attaching loads to lifting equipment).
- Check the capacity, condition and attachment of lifting fixtures on the load.
- Check the mass, integrity and stability (e.g. unbalanced or shifting center of gravity) of the load.

### WARNING

#### Falling Mechanical Parts

Falling mechanical parts can cause serious injury or death by impact, crushing, severing or trapping.

To prevent injury and before lifting the alternator:

- Do not lift the complete generator set by the alternator lifting fixtures.
- Keep the alternator horizontal when lifting.
- Fit drive end and non-drive end transit fittings to single bearing alternators to keep the main rotor in the frame.

Do not remove the lifting label attached to one of the lifting points.

## 2.10 Alternator Operating Areas

### WARNING

#### Ejected Debris

Debris ejected during catastrophic failure can cause serious injury or death by impact, severing or stabbing.

To prevent injury:

- Keep away from the air inlet and air outlet when the alternator is running.
- Do not put operator controls near the air inlet and air outlet.
- Do not cause overheating by running the alternator outside rating plate parameters.
- Do not overload the alternator.
- Do not run an alternator with excessive vibration.
- Do not synchronize parallel alternators outside the specified parameters.

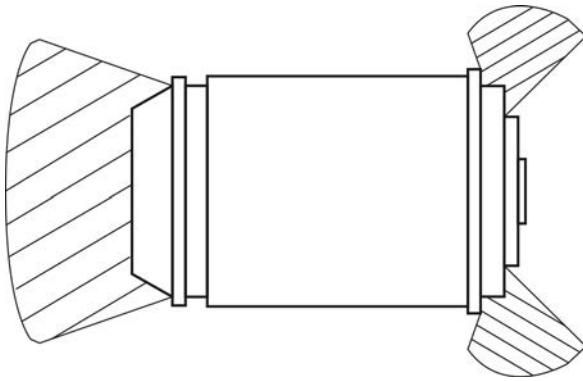

Always wear suitable PPE when working in hatched areas or directly in-line with any air inlet/outlet.

Make sure this consideration is captured in your risk assessment.

## 2.11 Hazard Warning Labels

⚠ WARNING
<p><b>Safety Cover Removed</b>  <b>A hazard exposed when a safety cover is removed can cause serious injury or death.</b>  <b>To prevent injury:</b></p> <ul style="list-style-type: none"> <li>• Fit the safety labels at the locations shown on the back of the label sheet supplied.</li> <li>• Observe the safety labels.</li> <li>• Refer to the service manual before removing covers.</li> </ul>

The generator set manufacturer is responsible for fitting the self-adhesive hazard warning labels supplied with the alternator.

Replace labels that are missing, damaged or painted over.





# 3 Safety Directives and Standards

STAMFORD Alternators meet applicable European safety directives, and national and international standards relevant to alternators. The alternator must be operated within the limits specified in the relevant standards and within the parameters on the alternator rating plate.

Marine alternators meet the requirements of all the major marine classification societies.

## 3.1 Low Voltage Directive: Declaration of Conformity

TABLE 1. LOW VOLTAGE DIRECTIVE: DECLARATION OF CONFORMITY

<b>2006/95/EC LOW VOLTAGE DIRECTIVE</b> <b>DECLARATION OF CONFORMITY</b>		
<p>This synchronous A.C. generator is designed for incorporation into an electricity generating-set and fulfils all the relevant provisions of the following EC Directive(s) when installed in accordance with the installation instructions contained in the product documentation:</p>		
<p>2006/95/EC 2004/108/EC</p>	<p>Low Voltage Directive The Electromagnetic Compatibility (EMC) Directive</p>	
<p>and that the standards and/or technical specifications referenced below have been applied:</p>		
<p>EN 61000-6-2:2005 EN 61000-6-4:2007+A1:2011 EN ISO 12100:2010 EN 60034-1:2010 BS ISO 8528-3:2005 BS 5000-3:2006</p>	<p>Electromagnetic compatibility (EMC). Generic standards – Part 6-2: Immunity for industrial environments Electromagnetic compatibility (EMC). Generic standards – Part 6-4: Emission standard for industrial environments Safety of machinery – General principles for design – Risk assessment and risk reduction Rotating electrical machines - Part 1: Rating and performance Reciprocating internal combustion engine driven alternating current generating sets - Part 3: Alternating current generators for generating sets Rotating electrical machines of particular types or for particular applications - Part 3: Generators to be driven by reciprocating internal combustion engines - Requirements for resistance to vibration</p>	
<p>The name and address of authorised representative, authorised to compile the relevant technical documentation, is the Company Secretary, Cummins Generator Technologies Limited, 49/51 Gresham Road, Staines, Middlesex, TW18 2BD, U.K.</p>		
<p>Date: 01<sup>st</sup> February 2014</p>  <p>Signed:</p>	<p>Name, Title and Address: Kevan J Simon Global Technical and Quality Director Cummins Generator Technologies Fountain Court Lynch Wood Peterborough, UK PE2 6FZ</p>	
Description	Serial Number	
<p><small>Registered in England under Registration No. 441273. Cummins Generator Technologies Ltd. Registered Office: Barnack Road, Stamford, Lincolnshire PE9 2NB, England.</small></p>		
<p><small>DRAWING REF 450-16383-D</small></p>		

## 3.2 Machinery Directive: Declaration of Incorporation

TABLE 2. MACHINERY DIRECTIVE: DECLARATION OF INCORPORATION - SHEET 1

<b>2006/42/EC MACHINERY DIRECTIVE</b> <b>DECLARATION OF INCORPORATION</b> <b>OF PARTLY COMPLETED MACHINERY</b>						
<b>Function: Synchronous A.C. generator designed for incorporation into an electricity generating-set.</b>						
<b>The partly completed machinery supplied with this declaration:</b> <ul style="list-style-type: none"> <li>• Is designed and constructed solely as a non-functional component to be incorporated into a machine requiring completion.</li> <li>• Is designed to comply with the provisions of the following EU Directives so far as their level of build will allow:                             <table style="margin-left: 20px; border: none;"> <tr> <td style="padding-right: 20px;">2004/108/EC</td> <td>The Electromagnetic Compatibility (EMC) Directive</td> </tr> <tr> <td>2006/95/EC</td> <td>Low Voltage Directive</td> </tr> </table> </li> <li>• Must not be put into service within the European Community ("EC") until the final machinery into which it is to be incorporated has been declared in conformity with the Machinery Directive and all other applicable EC Directives.</li> <li>• Is designed and constructed to comply with the essential health and safety requirements of the Machinery Directive 2006/42/EC listed on sheet 2 of this Declaration.</li> </ul> <p>The relevant technical documentation is compiled in accordance with the provisions of part B of Annex VII of the Machinery Directive. All relevant information about the partly completed machinery will be provided, in writing, on a reasoned request by the appropriate national authority to its authorised representative. The name and address of authorised representative, authorised to compile the relevant technical documentation, is the Company Secretary, Cummins Generator Technologies Limited, 49/51 Gresham Road, Staines, Middlesex, TW18 2BD, U.K.</p>			2004/108/EC	The Electromagnetic Compatibility (EMC) Directive	2006/95/EC	Low Voltage Directive
2004/108/EC	The Electromagnetic Compatibility (EMC) Directive					
2006/95/EC	Low Voltage Directive					
<b>The undersigned representing the manufacturer:</b>						
<b>Date: 01<sup>st</sup> February 2014</b>    <b>Signed:</b>	<b>Name, Title and Address:</b> <b>Kevan J Simon</b> <b>Global Technical and Quality Director</b> <b>Cummins Generator Technologies</b> <b>Fountain Court</b> <b>Lynch Wood</b> <b>Peterborough, UK</b> <b>PE2 6FZ</b>					
Description	Serial Number					
Registered in England under Registration No. 441273. Cummins Generator Technologies Ltd, Registered Office: Barnack Road, Stamford, Lincolnshire PE9 2NB, England.						
DRAWING REF 450-16388-D						

TABLE 3. MACHINERY DIRECTIVE: DECLARATION OF INCORPORATION - SHEET 2

<p><b>2006/42/EC MACHINERY DIRECTIVE</b></p> <p><b>DECLARATION OF INCORPORATION</b></p> <p><b>OF PARTLY COMPLETED MACHINERY</b></p>	
	
<p><b>ESSENTIAL HEALTH AND SAFETY REQUIREMENTS RELATING TO THE DESIGN AND CONSTRUCTION OF PARTLY COMPLETED MACHINERY</b></p>	
<p><b>1.1 General Remarks</b></p> <ul style="list-style-type: none"> <li>• 1.1.2 : Principles of safety integration</li> <li>• 1.1.3 : Materials and products</li> <li>• 1.1.5 : Design of machinery to facilitate its handling</li> </ul> <p><b>1.3 Protection Against Mechanical Hazards</b></p> <ul style="list-style-type: none"> <li>• 1.3.1 : Risk of loss of stability</li> <li>• 1.3.2 : Risk of break-up during operation</li> <li>• 1.3.3 : Risks due to falling or ejected objects</li> <li>• 1.3.4 : Risks due to surfaces, edges or angles</li> <li>• 1.3.7 : Risks related to moving parts</li> <li>• 1.3.8.1 : Moving transmission parts</li> </ul> <p><b>1.4 Guarding *</b></p> <ul style="list-style-type: none"> <li>• 1.4.1 : Guards – General requirements *</li> <li>• 1.4.2.1 : Fixed guards *</li> </ul> <p><b>1.5 Other Hazards</b></p> <ul style="list-style-type: none"> <li>• 1.5.2 : Static electricity</li> <li>• 1.5.3 : Energy supply other than electric</li> <li>• 1.5.4 : Errors of fitting</li> <li>• 1.5.6 : Fire</li> <li>• 1.5.13 : Emissions of hazardous materials and substances</li> </ul> <p><b>1.7 Information</b></p> <ul style="list-style-type: none"> <li>• 1.7.1 : Information and warnings on the machinery</li> <li>• 1.7.4 : Instructions</li> </ul>	<p><b>LEGEND</b></p> <ol style="list-style-type: none"> <li><b>1. Essential Health and Safety Requirements not shown are not considered applicable for this Partly Completed Machinery or must be fulfilled by the assembler of the Machinery.</b></li> <li><b>2. Essential Health and Safety Requirements shown are considered applicable for this Partly Completed Machinery and have been fulfilled by the manufacturer to the extent possible, subject to the build requirements of the Machinery assembler, the information contained in the assembly instructions and Cummins bulletins.</b></li> <li><b>3. * Customers may request Partly Completed Machinery without some or all guarding attached. In these cases section 1.4 Guarding does not apply and the Essential Health and Safety Requirements for guarding must be fulfilled by the assembler of the Machinery.</b></li> </ol>
<p><small>Registered in England under Registration No. 441273.</small></p> <p><small>Cummins Generator Technologies Ltd. Registered Office: Barnack Road, Stamford, Lincolnshire PE9 2NB, England.</small></p>	
<p><small>DRAWING REF 450-16388-D</small></p>	

### 3.3 Additional Information for EMC Compliance

STAMFORD alternators are designed to meet EMC emissions and immunity standards for industrial environments. Additional equipment may be required when the alternator is installed in residential, commercial and light industrial environments.

The installation 'earth/ground' arrangements require the connection of the alternator frame to the site protective earth conductor using a minimum lead length.

---

Installation, maintenance and servicing must be carried out by adequately trained personnel fully aware of the requirements of the relevant EC directives.

***NOTICE***

**Cummins Generator Technologies is not liable for EMC compliance if unauthorized parts, not of STAMFORD brand, are used for maintenance and servicing.**

# 4 Introduction

---

## 4.1 General Description

PG80 alternators are of brushless rotating field design, available in the following ranges:

- Low Voltage (LV) up to 1000 V, 50 Hz (1500 RPM, 4 pole) and 1000 V, 60 Hz (1800 RPM, 4 pole).
- Medium Voltage (MV) up to 3.3 kV, 50 Hz (1500 RPM, 4 pole) and 4.16 kV, 60 Hz (1800 RPM, 4 pole).
- High Voltage (HV) up to 13.8 kV, 50 Hz (1500 RPM, 4 pole) and 13.8 kV, 60 Hz (1800 RPM, 4 pole).

PG80 alternators have an excitation system which uses a MA330 or DM110 AVR, powered by a permanent magnet generator (PMG).

## 4.2 Alternator Name

TABLE 4. PG80 ALTERNATOR NAMING FORMAT

Example:	PG	80	-	L	V	S	I	80	4	R	2
	Alternator model (PG80)			Alternator type (LV/MV/HV = low/medium/high voltage)		(S = standard, X = special)	Application (I = industrial, M = marine)	Frame size (80)	Number of poles	Core length (R, S, T, W, X, Y)	Number of bearings (1 = NDE, 2 = DE & NDE)

## 4.3 Serial Number Location

A unique serial number is stamped into the upper section of the drive end bracket and shown on two labels on the outside of the terminal box.

## 4.4 Rating Plate

⚠ WARNING	
<b>Ejected Debris</b>	
Debris ejected during catastrophic failure can cause serious injury or death by impact, severing or stabbing.	
To prevent injury:	
<ul style="list-style-type: none"> <li>• Keep away from the air inlet and air outlet when the alternator is running.</li> <li>• Do not put operator controls near the air inlet and air outlet.</li> <li>• Do not cause overheating by running the alternator outside rating plate parameters.</li> <li>• Do not overload the alternator.</li> <li>• Do not run an alternator with excessive vibration.</li> <li>• Do not synchronize parallel alternators outside the specified parameters.</li> </ul>	

The self-adhesive rating plate label, supplied with the alternator, must be fixed after the generator set is fully assembled and painted.

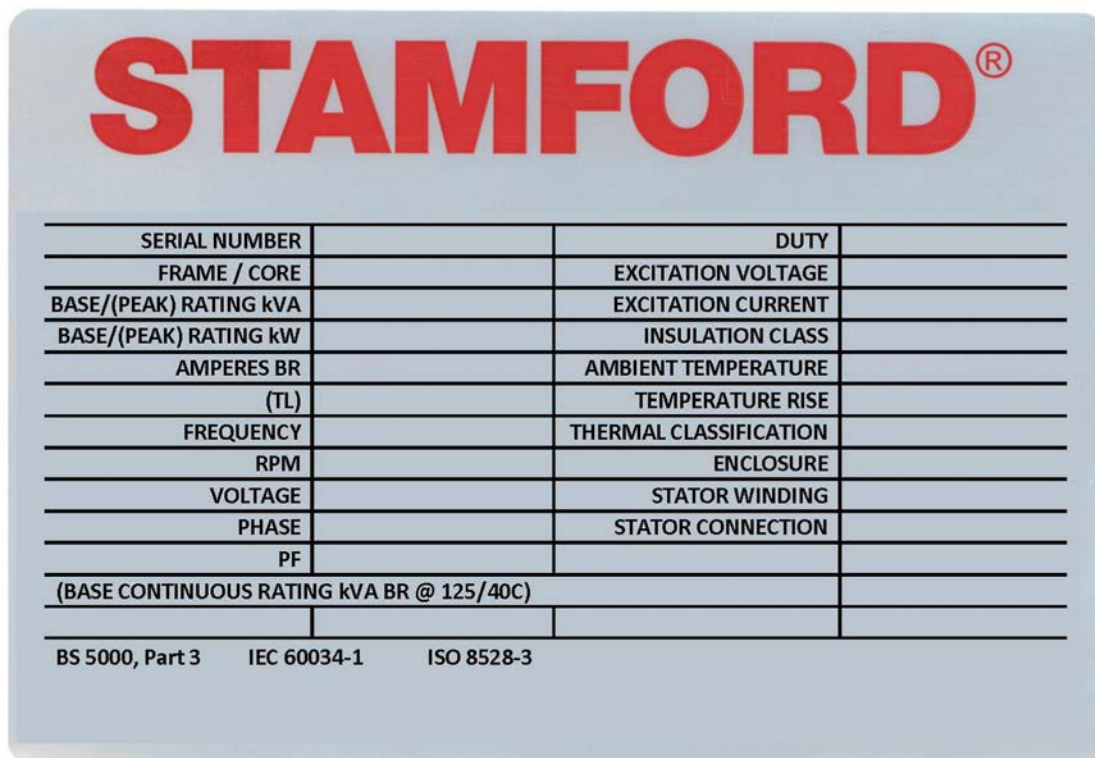
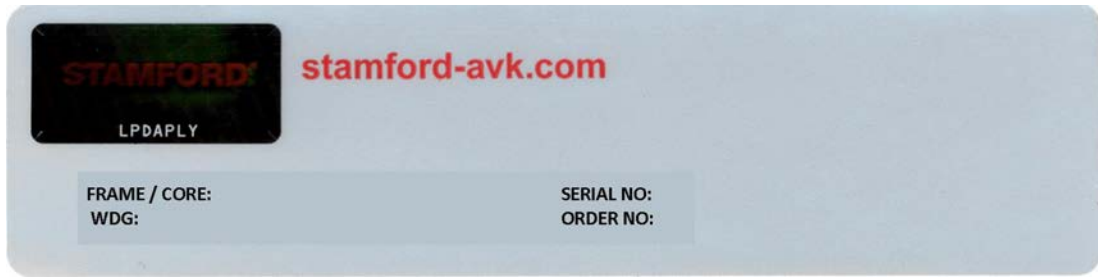

FIGURE 1. GLOBAL STAMFORD ALTERNATOR RATING PLATE

## 4.5 Product Authentication

The STAMFORD high security, anti-counterfeit hologram is located on the Tracking Label. Check that the dots are visible around the STAMFORD logo when viewing the hologram from different angles and the word "GENUINE" appears behind the logo. Use a flashlight to see these security features in low ambient light. Check that the alternator is genuine by entering the unique 7 character hologram code at [www.stamford-avk.com/verify](http://www.stamford-avk.com/verify).





**FIGURE 2. TRACKING LABEL**



**FIGURE 3. DOTS VISIBLE IN LEFT, RIGHT, UPPER AND LOWER VIEWS OF 3D HOLOGRAM**

-

---

This page is intentionally blank.

# 5 Application of the Alternator

 <b>WARNING</b>	
<b>Ejected Debris</b>	
Debris ejected during catastrophic failure can cause serious injury or death by impact, severing or stabbing.	
To prevent injury:	
<ul style="list-style-type: none"> <li>• Keep away from the air inlet and air outlet when the alternator is running.</li> <li>• Do not put operator controls near the air inlet and air outlet.</li> <li>• Do not cause overheating by running the alternator outside rating plate parameters.</li> <li>• Do not overload the alternator.</li> <li>• Do not run an alternator with excessive vibration.</li> <li>• Do not synchronize parallel alternators outside the specified parameters.</li> </ul>	

It is the customer's responsibility to make sure that the selected alternator is suitable for the final application.

## 5.1 Environment

The alternators are protected to IP23 as standard. IP23 is not adequate protection for use outdoors without additional measures.

Ambient Temperature	-15° C to 40° C (5° F to 104° F)
Relative Humidity	< 70%
Altitude	< 1000 m (3280 ft)

The alternator has been designed for the environment shown in the table. The alternator can operate outside these conditions if it is rated accordingly; the nameplate gives details. If the operating environment is changed after purchase, refer to the factory for a revised alternator rating.

## 5.2 Air Flow

**TABLE 5. MINIMUM AIR FLOW AND MAXIMUM PRESSURE DROP**

Alternator model and frequency	50 Hz	60 Hz	Maximum intake to outlet pressure drop, mm (in) water gauge
	Minimum Air flow, m <sup>3</sup> /s (ft <sup>3</sup> /min)		
P80 (R, S, T)	3.2 (6780)	3.7 (7840)	13 (0.5)
P80 (W, X, Y)	4.0 (8475)	4.7 (9959)	13 (0.5)

Make sure that the air inlets and outlets are not obstructed when the alternator is running. For alternators with air filters, a supplied differential pressure switch is configured at the factory with appropriate alarm and shutdown settings for customer use.

---

## 5.3 Airborne Contaminants

Contaminants such as salt, oil, exhaust fumes, chemicals, dust, and sand will reduce the effectiveness of the insulation and the life of the windings. Consider using air filters and an enclosure to protect the alternator.

## 5.4 Air Filters

Air filters trap airborne particulates above 5 microns. The filters must be cleaned or replaced regularly, depending on site conditions. Check the filters frequently to establish an appropriate service interval.

Alternators with factory-fitted filters are rated to account for the reduced flow rate of cooling air. If filters are retrofitted, the alternator rating must be reduced by 5%.

Air filters do not remove water. Keep the filters dry with additional protection. Wet filters further restrict airflow, causing the alternator to overheat and leading to premature failure of the insulation.

## 5.5 Humid Conditions

The water carrying capacity of air depends on temperature. If the air temperature falls below its saturation point, dew may form on the windings, reducing the electrical resistance of the insulation. In humid conditions, additional protection may be required even if the alternator is fitted inside an enclosure. Anti-condensation heaters are supplied on request.

## 5.6 Anti-Condensation Heaters

 **DANGER**

**Live Electrical Conductors**

**Live electrical conductors can cause serious injury or death by electric shock and burns.**

**To prevent injury and before removing covers over electrical conductors, isolate the generator set from all energy sources, remove stored energy and use lock out/tag out safety procedures.**

Power to the anti-condensation heater is supplied from a separate source. Anti-condensation heaters raise the air temperature around the windings to deter condensation forming in humid conditions when the alternator is not operating. Best practice is to energize the heaters automatically when the alternator is off.

## 5.7 Enclosures

Fit an enclosure to protect the alternator from adverse environmental conditions. Make sure that air entering the alternator is of adequate flowrate, free from moisture and contaminants, and below the maximum ambient temperature on the rating plate.

Make sure there is sufficient access around the alternator for safe maintenance.

## 5.8 Vibration

The alternators are designed to withstand the vibration levels encountered on generator sets built to meet the requirements of ISO 8528-9 and BS 5000-3. (Where ISO 8528 is taken to be broad band measurements and BS5000 refers to the predominant frequency of any vibrations on the generator set).

### NOTICE

Exceeding either of the above specifications will have a detrimental effect on the life of the bearings and other components, and may invalidate the alternator warranty.

### NOTICE

The terminal box is designed to support the fitted busbars or terminals, transformers, load cables and auxiliary terminal box. Additional mass could cause excessive vibration and lead to failure of the terminal box enclosure and mounting. Refer to the Installation Manual to connect the load cables to the terminal box. Refer to CGT before fixing any additional mass to the terminal box.

### 5.8.1 Definition of BS5000–3

Alternators shall be capable of continuously withstanding linear vibration levels with amplitudes of 0.25 mm between 5 Hz and 8 Hz, and velocities of 9.0 mm/s RMS between 8 Hz and 200 Hz, when measured at any point directly on the carcass or main frame of the machine. These limits refer only to the predominant frequency of vibration of any complex waveform.

### 5.8.2 Definition of ISO 8528-9

ISO 8528-9 refers to a broad band of frequencies; the broad band is taken to be between 10 Hertz and 1000 Hertz. The table below is an extract from ISO 8528-9 (Table C.1, value 1). This simplified table lists the vibration limits by kVA and speed for acceptable operation of standard generator set designs.

### 5.8.3 Vibration Frequencies

The main vibration frequencies produced by the alternator are as follows:

- 4-pole 1500 RPM 25 Hz
- 4-pole 1800 RPM 30 Hz

Vibrations induced in the alternator by the engine are complex. It is the responsibility of the generator set designer to ensure that the alignment and stiffness of the bedplate and mountings do not allow vibration to exceed BS5000 part 3 and ISO 8528 part 9 limits.

### 5.8.4 Linear Vibration Limits

Linear Vibration Levels As Measured On The Alternator - P80				
Engine Speed RPM (min <sup>-1</sup> )	Power Output S (kVA)	Vibration Displacement RMS (mm)	Vibration Velocity RMS (mm/s)	Vibration Acceleration RMS (mm/s <sup>2</sup> )
1300 ≤ RPM ≤ 2000	250 < S	0.32	20	13
The broad band is taken as 10 Hz - 1000 Hz				

## 5.8.5 Linear Vibration Monitoring

We recommend using vibration analyzing equipment to measure vibration at the positions shown below. Check that vibration of the generator set is below the limits stated in the standards. If vibration is above the limits, the generator set builder should investigate the root causes and eliminate them. Best practice is for the generator set builder to take initial readings as a reference and for the user to periodically monitor vibration, according to the recommended service schedule, to detect a deteriorating trend.

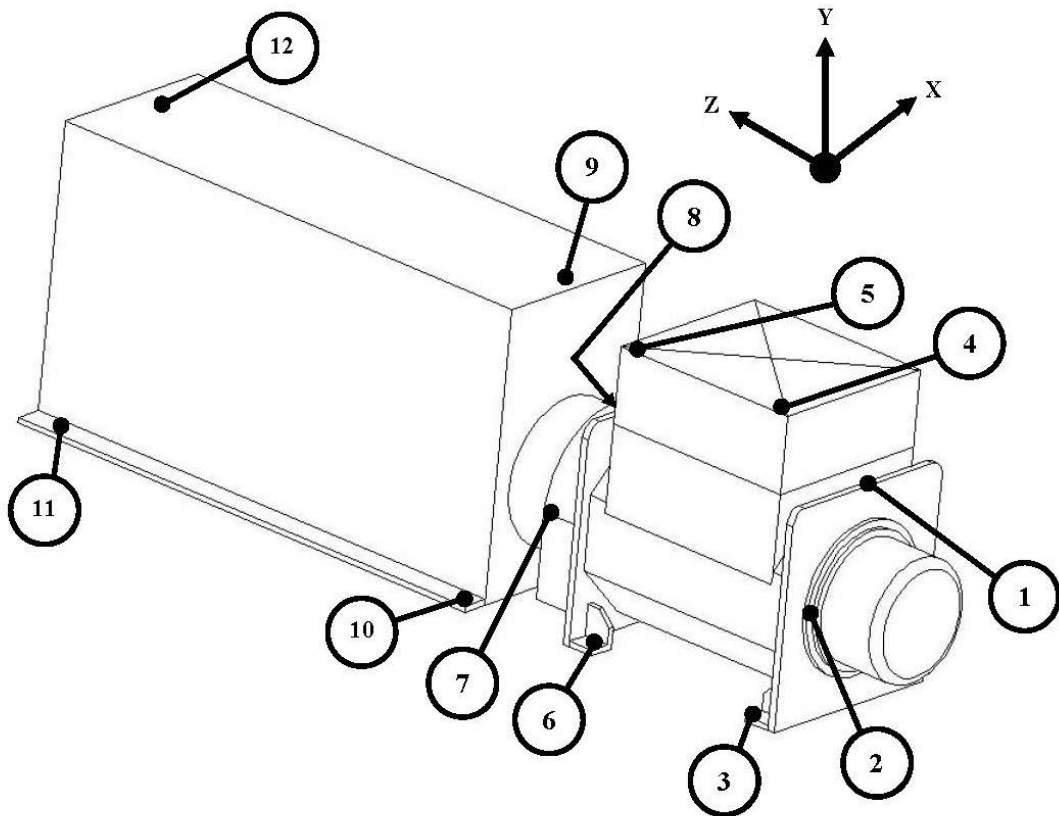

## 5.8.6 Excessive Vibration

### WARNING

#### Ejected Debris

Debris ejected during catastrophic failure can cause serious injury or death by impact, severing or stabbing.

To prevent injury:

- Keep away from the air inlet and air outlet when the alternator is running.
- Do not put operator controls near the air inlet and air outlet.
- Do not cause overheating by running the alternator outside rating plate parameters.
- Do not overload the alternator.
- Do not run an alternator with excessive vibration.
- Do not synchronize parallel alternators outside the specified parameters.

---

If the measured vibration of the generator set is not within the limits:

1. The generator set manufacturer should change the generator set design to reduce the vibration levels as much as possible.
2. Contact Cummins Generator Technologies to assess the impact on bearing and alternator life expectancy.

## **5.9 Bearings**

### **5.9.1 Re-greasable Bearings**

Each bearing housing is connected by a grease pipe to an external grease nipple. A label gives the grease type and quantity, and frequency for re-greasing. The recommended grease is a high specification synthetic compound that must not be mixed with grease of a different specification. Refer to the Service and Maintenance chapter for detailed instructions.

### **5.9.2 Bearing Life**

Factors that reduce bearing life or lead to bearing failure include:

- Adverse operating conditions and environment
- Stress caused by misalignment of the generator set
- Vibration from the engine that exceeds the limits in BS 5000-3 and ISO 8528-9
- Long periods (including transportation) when the alternator is stationary and subjected to vibration can cause false brinelling wear (flats on the balls and grooves on the races)
- Very humid or wet conditions that cause corrosion and deterioration of the grease by emulsification.

### **5.9.3 Health Monitoring of the Bearings**

We recommend that the user checks the bearing condition using vibration monitoring equipment. Best practice is to take initial readings as a reference and periodically monitor the bearings to detect a deteriorating trend. It will then be possible to plan a bearing change at an appropriate generator set or engine service interval.

### **5.9.4 Bearing Service Life Expectancy**

Bearing manufacturers recognize that the service life of bearings depends on factors that are outside their control. Rather than quote a service life, practicable replacement intervals are based on the L10 life of the bearing, the type of grease, and the recommendations of the bearing and grease manufacturers.

For general purpose applications: If the correct maintenance is carried out, vibration levels do not exceed the levels stated in ISO 8528-9 and BS5000-3, and the ambient temperature does not exceed 50 °C, plan to replace the bearings within 30,000 hours of operation.

If in doubt regarding any aspect of bearing life of a STAMFORD alternator, contact the nearest authorized supplier of the STAMFORD factory.

### **5.9.5 Standby Applications**

Run alternators in standby applications at no load for a minimum of 10 minutes every week. For alternators fitted with regreasable bearings, re-grease the bearings every 6 months, regardless of the number of accumulated running hours.

-

---

This page is intentionally blank.



# 6 Installation into the Generator Set

## 6.1 Alternator Dimensions

Dimensions are included in the data sheet specific to the alternator model. Refer to the rating plate to identify the alternator model.

### NOTICE

Data sheets are available from [www.stamford-avk.com](http://www.stamford-avk.com)

## 6.2 Lifting the Alternator

### WARNING

#### Falling Mechanical Parts

Falling mechanical parts can cause serious injury or death by impact, crushing, severing or trapping.

To prevent injury and before lifting the alternator:

- Do not lift the complete generator set by the alternator lifting fixtures.
- Keep the alternator horizontal when lifting.
- Fit drive end and non-drive end transit fittings to single bearing alternators to keep the main rotor in the frame.

### NOTICE

A shock load detector fitted on the DE bracket activates if the alternator is subjected to a 15g acceleration. If the detector has been activated, the alternator must be inspected for damage by CGT. As a minimum, the bearings must be replaced.

Lift the alternator by shackles attached to the lifting points (lugs or eyes) provided. A label attached to a lifting point shows the correct lifting arrangement. Use chains of sufficient length, and a spreader bar if necessary, to make sure that the chains are vertical when lifting. Make sure that the capacity of the lifting equipment is sufficient for the alternator mass shown on the label.

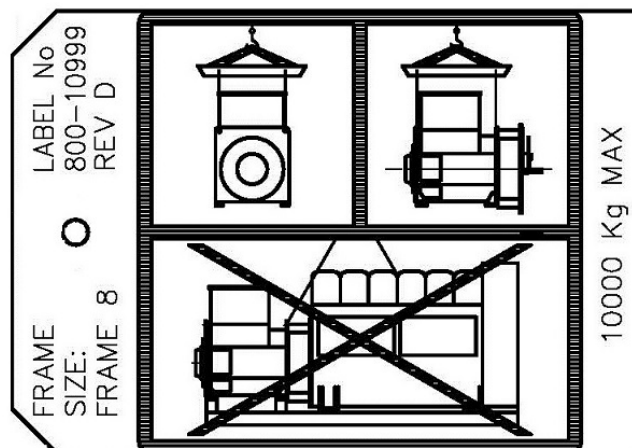

FIGURE 4. LIFTING LABEL

## 6.3 Storage

If the alternator will not to be used immediately, it must be stored in a clean, dry, vibration-free environment. We recommend the use of anti-condensation heaters, when available.

If the alternator can be rotated, turn the rotor a minimum of 6 revolutions every month during storage.

If the automatic re-greaser is fitted and powered, press the operator button 2 (refer to [Figure 10 on page 38](#)) for 2 seconds every month to trigger one additional lubrication which stirs the grease in the reservoir.

### 6.3.1 After Storage

After a period of storage, carry out the pre-running checks to determine the condition of the windings. If the windings are damp or the insulation resistance is low, follow one of the drying out procedures (see [Chapter 7 on page 31](#)).

Before putting the alternator into service, refer to the following tables.

**TABLE 6. AFTER STORAGE, WITHOUT AUTOMATIC RE-GREASER FITTED**

	<b>Not Rotated during Storage</b>	<b>Rotated during Storage</b>
<b>Sealed Bearing(s)</b>	If stored less than 12 months, put the alternator into service. If stored more than 12 months, replace the bearing(s) then put the alternator into service.	If stored less than 24 months, put the alternator into service. If stored more than 24 months, replace the bearing(s) then put the alternator into service.
<b>Re-greasable Bearing(s) without Automatic Re-greaser</b>	If stored less than 12 months, put the alternator into service. If stored more than 12 months, replace the bearing(s) then put the alternator into service.	If stored less than 6 months, put the alternator into service. If stored between 6 and 24 months, re-grease the bearing(s) during the first run then put the alternator into service. If stored more than 24 months, replace the bearing(s) then put the alternator into service.

**TABLE 7. AFTER STORAGE, WITH AUTOMATIC RE-GREASER FITTED**

	<b>Not Rotated and/or Not Stirred during Storage</b>	<b>Rotated and Stirred during Storage</b>
<b>Re-greasable Bearing(s) with Automatic Re-greaser</b>	If stored less than 12 months, put the alternator into service. If stored more than 12 months, replace the bearing(s) and replace the complete auto re-greasing system (pump unit and grease pipes), then put the alternator into service.	If stored less than 24 months, put the alternator into service. If stored more than 24 months, replace the bearing(s) and replace the complete auto re-greasing system (pump unit and grease pipes), then put the alternator into service.

### 6.3.2 Storage Instruction

When an alternator is stationary, in storage or otherwise, it may be subjected to environmental factors, such as vibration, humidity, temperature and airborne contaminant particles, that could degrade the bearing arrangements.

Contact CGT for advice in advance if the alternator will be stationary for long periods.

## 6.4 Generator Set Coupling

### WARNING

#### Moving Mechanical Parts

Moving mechanical parts during generator set coupling can cause serious injury by crushing, severing or trapping.

To prevent injury, keep arms, hands and fingers away from mating surfaces when coupling the generator set.

### NOTICE

Do not attempt to rotate the alternator rotor by levering against the vanes of the cooling fan. The fan is not designed to withstand such forces and will be damaged.

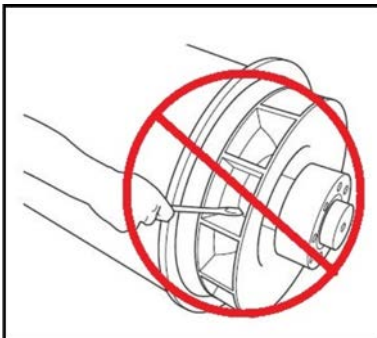

Efficient operation and long component life depend on minimizing mechanical stresses on the alternator. When coupled in a generator set, misalignment and vibration interactions with the prime mover engine can cause mechanical stress.

A coupling mass greater than 150 kg will reduce bearing life significantly. Refer to the factory for further information.

generator sets need a substantial flat continuous bedplate to suit the installation site floor loading, with engine and alternator mounting pads to make a firm base for accurate alignment. The height of all mounting pads must be within 0.25 mm for skid mounting, 3 mm for non-adjustable anti-vibration mounts (AVM) or 10 mm for adjustable height AVMs. Use shims to achieve level. The rotational axes of alternator rotor and engine output shaft must be coaxial (radial alignment) and perpendicular to the same plane (angular alignment). The axial alignment of the alternator and engine coupling must be within 0.5 mm, to allow for thermal expansion without unwanted axial force on the bearings at operating temperature.

Vibration can occur by flexing of the coupling. The alternator is designed for a maximum bending moment not exceeding 275 kgm (2000 lbs ft). Check the maximum bending moment of the engine flange with the engine manufacturer.

Torsional vibrations occur in all engine-driven shaft systems and may be large enough to cause damage at critical speeds. The generator set builder must consider the effect of torsional vibration on the alternator shaft and couplings, referring to the torsional drawings supplied for shaft dimensions and rotor inertia.

Close-coupling of alternator and engine can increase the rigidity of the generator set. Both single and two bearing alternators can be close-coupled. The generator set builder must supply guarding for open-coupled applications.

To prevent rust during transit and storage, the alternator frame spigot, rotor coupling plates and shaft extension have been treated with a rust preventative coating. Remove this before coupling the generator set.

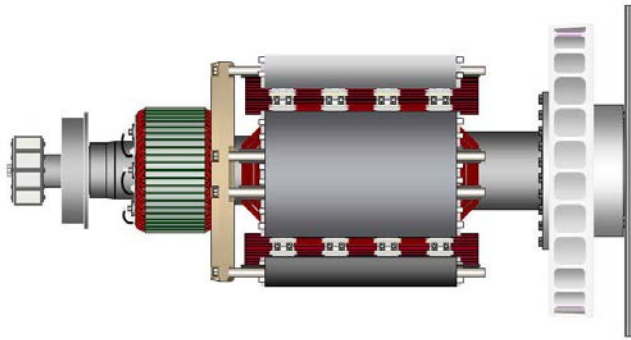

**FIGURE 5. SINGLE BEARING ALTERNATOR ROTOR SHOWING COUPLING DISCS BOLTED TO DRIVE END COUPLING HUB (AT RIGHT)**

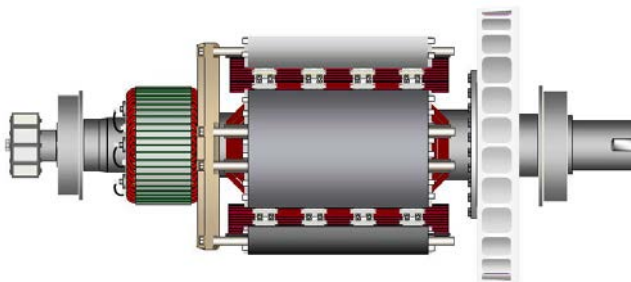

**FIGURE 6. TWO BEARING ALTERNATOR ROTOR SHOWING SHAFT WITH KEYWAY FOR FLEXIBLE COUPLING (AT RIGHT)**

## 6.5 Single Bearing

### **WARNING**

#### **Falling Mechanical Parts**

Falling mechanical parts can cause serious injury or death by impact, crushing, severing or trapping.

To prevent injury and before lifting the alternator:

- Do not lift the complete generator set by the alternator lifting fixtures.
- Keep the alternator horizontal when lifting.
- Fit drive end and non-drive end transit fittings to single bearing alternators to keep the main rotor in the frame.

1. Check that the bracket which supports the rotor underneath the fan hub is fitted in position.
2. Position the alternator close to the engine and remove the drive end transit bracket that keeps the rotor in place during transport.
3. Remove the air outlet covers from the drive end of the alternator to access the coupling and adaptor bolts.

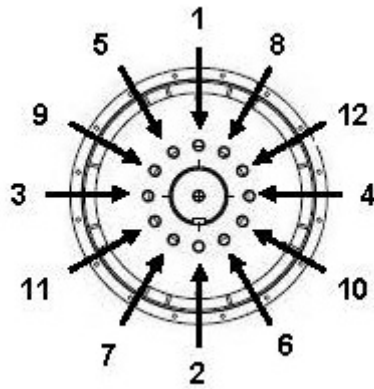

4. If required, tighten the coupling disc bolts in the sequence shown above.
5. Check the torque of bolts that fasten the coupling discs to the DE coupling hub in a clockwise direction around the bolt circle.
6. Make sure the coupling discs are concentric with the adaptor spigot. Use alignment studs to ensure that the disc and the flywheel are in alignment.
7. Make sure the axial distance from the coupling mating face on the flywheel to the mating face on the flywheel housing is within 0.5mm of nominal dimension. This ensures that the engine crankshaft float is maintained and the alternator rotor position is neutral, allowing for thermal expansion. There is no axial pre-load thrust on the engine or alternator bearings.
8. Offer the alternator to the engine and engage coupling discs and housing spigots at the same time, pushing the alternator towards the engine until the coupling discs are against the flywheel face and the housing spigots are located.

**NOTICE**

**Do not pull the alternator to the engine using bolts through the flexible discs.**

9. Fit heavy gauge washers under the heads of housing and coupling bolts. Screw in the bolts evenly around the coupling assembly to maintain correct alignment.

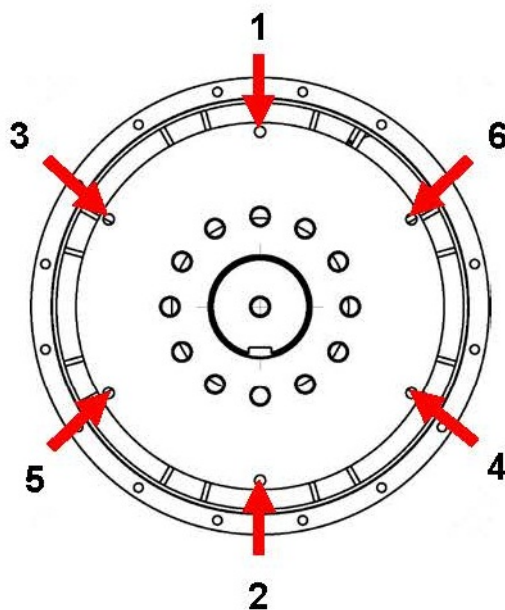

10. Tighten the bolts to fix the coupling disc to the flywheel, in the sequence shown above.

- 
11. Check the torque of each bolt in a clockwise direction around the bolt circle to ensure all the bolts are tight. Refer to the engine manufacturer's manual for correct tightening torque.
  12. Remove the rotor support bracket.
  13. Replace all covers.

## 6.6 Two Bearing

A flexible coupling, designed to suit the specific engine/alternator combination, is recommended to minimise torsional vibration effects.

If a close coupling adaptor is used the alignment of machined faces must be checked by offering the alternator up to the engine. Shim the alternator feet if necessary.

## 6.7 Pre-Running Checks

Before starting the generator set, test the insulation resistance of windings, check all connections are tight and in the correct location. Ensure the alternator air path is clear of obstructions. Replace all covers.

## 6.8 Direction of Rotation

As standard, alternator rotation is clockwise, as viewed from the drive end (unless counter-clockwise rotation is specified when ordering). The fan must be changed if the direction of rotation is changed; please seek advice from Cummins Generator Technologies.

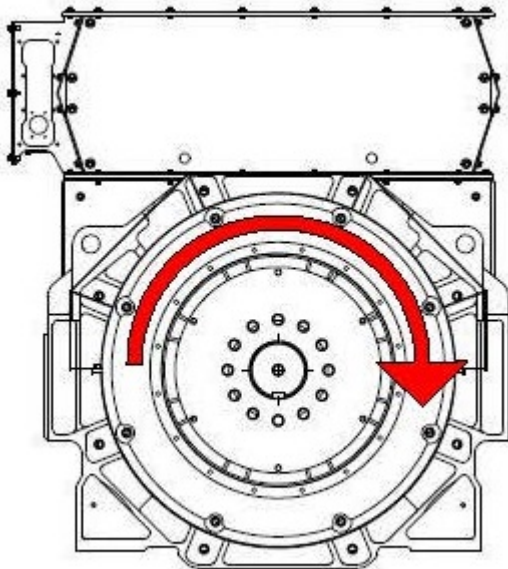

## 6.9 Phase Rotation

Main stator output is connected for a phase sequence of U V W when the alternator runs clockwise, as viewed from the drive end. If the phase rotation must be reversed, the customer must re-connect the output cables in the terminal box. Ask Cummins Generator Technologies for a circuit diagram of 'reverse phase connections'.

---

## 6.10 Voltage and Frequency

Check that the voltage and frequency shown on the alternator rating plate meet the requirements of the generator set application.

## 6.11 AVR Settings

The AVR is factory set for initial running tests. Check that the AVR settings are compatible with your required output. Refer to detailed instructions in the AVR manual for on- and off-load adjustments.

## 6.12 Electrical Connections

### WARNING

#### **Incorrect Electrical Installation and System Protection**

**Incorrect electrical installation and system protection can cause serious injury or death by electric shock and burns.**

**To prevent injury, installers must be qualified and are responsible for meeting appropriate inspectorate and local electricity authority requirements and site safety rules.**

### NOTICE

**The terminal box is designed to support the fitted busbars or terminals, transformers, load cables and auxiliary terminal box. Additional mass could cause excessive vibration and lead to failure of the terminal box enclosure and mounting. Refer to CGT before fixing any additional mass to the terminal box.**

### 6.12.1 Electrical Connections

Fault current curves and alternator reactance values are available on request from the factory so that the system designer can calculate the necessary fault protection and/or discrimination.

The installer must check that the alternator frame is bonded to the generator set bedplate, and must bond to site earth. If anti-vibration mounts are fitted between the alternator frame and its bedplate, a suitably-rated earth conductor must bridge across the anti-vibration mount.

Refer to wiring diagrams for electrical connection of the load cables. Electrical connections are made in the terminal box, constructed with removable panels to suit site-specific cable entry and glanding. Route single core cables through the insulated or non-magnetic gland plates supplied. Panels must be removed to be drilled or cut to prevent swarf entering the terminal box or alternator. After wiring, inspect the terminal box, remove all debris using a vacuum cleaner if necessary and check that no internal components are damaged or disturbed.

As standard, the alternator neutral is not bonded to the alternator frame. If required, neutral may be connected to the earth terminal in the terminal box, by a conductor of at least one half of the sectional area of a phase lead.

Load cables must be supported appropriately to avoid a tight radius at the point of entry into the terminal box, clamped at the terminal box gland, and allow at least  $\pm 25$  mm movement by the alternator set on its anti-vibration mountings, without causing excessive stress to the cables and alternator load terminals.

---

The palm (flattened part) of load cable lugs must be clamped in direct contact with the main stator output conductors so that the whole palm area conducts the output current, as shown below in typical arrangements for insulated terminals and busbar. The tightening torque of M12 fasteners is 70 Nm (51.6 ft-lb) (main nut) and 45 Nm (33.2 ft-lb) (lock nut) on insulated terminals, or 80 Nm (59 ft-lb) on busbars. As specified when ordering, cable lugs can be fixed to top or bottom of the busbar, and by one or two fasteners.

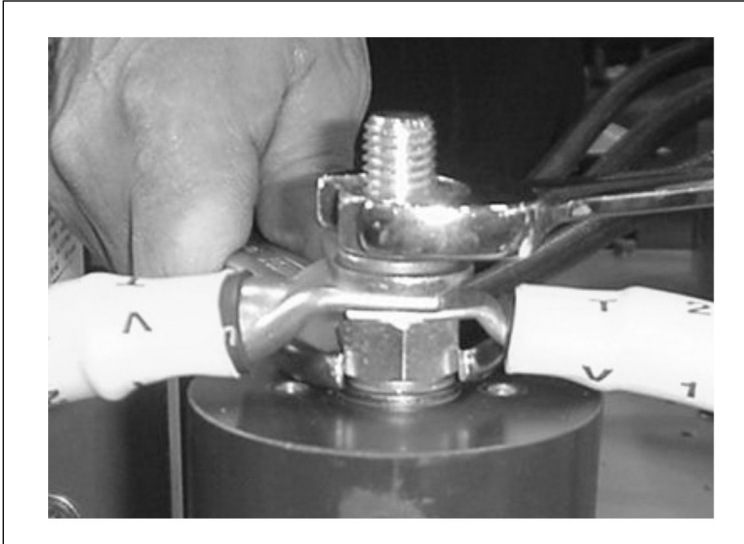

## 6.13 Grid Connection: Voltage Surges and Micro-Interruptions

Take precautions to prevent transient voltages generated by the connected load and/or the distribution system from causing damage to the alternator components.

To identify any possible risk, all aspects of the alternator's proposed application should be considered, especially the following:

- Loads with characteristics that result in large load step changes.
- Load control by switchgear, and power control by any method likely to generate transient voltage spikes.



- Distribution systems susceptible to external influences, such as lightning strikes.
- Applications involving parallel operation to a mains supply, where the risk of a mains disturbance in the form of a micro-interruption could occur.

If the alternator is at risk from voltage surges or micro-interruptions, include adequate protection into the generation system, usually with surge arrestors and suppressors, to meet regulations and installation requirements.

Surge protection must reduce the peak voltage at the alternator of a transient pulse of 5  $\mu$ s rise time to less than  $1.25 \times \sqrt{2} \times (2 \times \text{rated output voltage} + 1000 \text{ V})$ . Best practise is to fit protective devices close to the output terminals. Refer to guidance from professional bodies and specialist equipment suppliers for further advice.

## 6.14 Varying Load

Under certain conditions, load variations can reduce alternator life.

Identify any possible risk, especially the following:

- Large capacitive loads (for example Power Factor Correction equipment) can affect alternator stability and cause pole slip.
- Stepped grid voltage variation (for example Tap Changing).

If the alternator is at risk from varying load, include adequate protection into the generator set system by under-excitation protection.

## 6.15 Synchronization

### ⚠ WARNING

#### Ejected Debris

Debris ejected during catastrophic failure can cause serious injury or death by impact, severing or stabbing.

To prevent injury:

- Keep away from the air inlet and air outlet when the alternator is running.
- Do not put operator controls near the air inlet and air outlet.
- Do not cause overheating by running the alternator outside rating plate parameters.
- Do not overload the alternator.
- Do not run an alternator with excessive vibration.
- Do not synchronize parallel alternators outside the specified parameters.

### 6.15.1 Parallel or Synchronizing Alternators

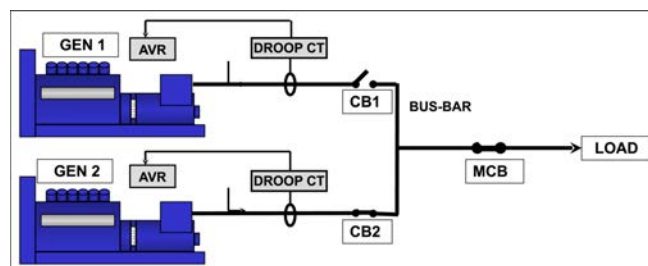

FIGURE 7. PARALLEL OR SYNCHRONIZING ALTERNATORS

The quadrature droop current transformer (Droop CT) gives a signal proportional to reactive current; the AVR adjusts excitation to reduce circulating current and allow each alternator to share reactive load. A factory-fitted droop CT is pre-set for 5% voltage drop at full-load zero power factor. Refer to the supplied AVR manual for droop adjustment.

- The synchronizing switch/breaker (CB1, CB2) must be of a type that will not cause “contact bounce” when it operates.
- The synchronizing switch/breaker must be adequately rated to withstand the continuous full load current of the alternator.
- The switch/breaker must be able to withstanding the rigorous closing cycles during synchronizing and the currents produced if the alternator is paralleled out of synchronism.
- The closing time of the synchronizing switch/breaker must be under the control of the synchronizer settings.
- The switch/breaker must be capable of operation under fault conditions such as short circuits. Alternator data sheets are available.

**NOTICE**

**The fault level may include a contribution from other alternators as well as from the grid/mains utility.**

The method of synchronizing should be either automatic, or by check synchronizing. The use of manual synchronizing is not recommended. The settings on the synchronizing equipment should be such that the alternator will close smoothly.

<b>The Phase sequence must match</b>	
Voltage difference	+/- 0.5%
Frequency difference	0.1 Hz/sec
Phase angle	+/- 10°
C/B closing time	50 ms

The settings for the synchronizing equipment to achieve this must be within these parameters.

The voltage difference when paralleling with the grid/mains utility is +/- 3% .

# 7 Service and Maintenance

---

## 7.1 Recommended Service Schedule

Refer to Safety Precautions section ([Chapter 2 on page 3](#)) of this manual before starting any service and maintenance activity.

Refer to Parts Identification section ([Chapter 8 on page 57](#)) for an exploded view of components and fastener information.

The recommended service schedule shows the recommended service activities in table rows, grouped by alternator subsystem. Columns of the table show the types of service activity, whether the alternator must be running, and the service levels. Service frequency is given in running hours or time interval, whichever is sooner. A cross (X) in the cells where a row intersects the columns shows a service activity type and when it is required. An asterisk (\*) shows a service activity done only when necessary.

All service levels in the recommended service schedule can be purchased directly from Cummins Generator Technologies Customer Service Department,

Telephone: +44 1780 484732,

Email: [service-engineers@cumminsgeneratortechnologies.com](mailto:service-engineers@cumminsgeneratortechnologies.com)

1. Proper service and repair are vital to the reliable operation of your alternator and the safety of anyone coming into contact with the alternator.
2. These service activities are intended to maximize the life of the alternator but shall not vary, extend or change the terms of the manufacturer's standard warranty or your obligations in that warranty.
3. Each service interval is a guide only, and developed on the basis that the alternator was installed and is operated in accordance with the manufacturer's guidelines. If the alternator is located and/or operated in adverse or unusual environmental conditions, the service intervals may need to be more frequent. The alternator should be continually monitored between services to identify any potential failure modes, signs of misuse, or excessive wear and tear.

**TABLE 8. ALTERNATOR SERVICE SCHEDULE**

System	SERVICE ACTIVITY  X = required * = if necessary	Alternator running	TYPE				SERVICE LEVEL								
			Inspect	Test	Clean	Refill/Replace	Commission	Post Commission	250 hrs / 0.5 year	Level 1	1000 hrs / 1 year	Level 2	10,000 hrs / 2 years	Level 3	30,000 hrs / 5 years
Alternator	Alternator rating		X				X								
	Bedplate arrangement		X				X								
	Coupling arrangement		X				X					*		X	
	Environmental conditions and cleanliness		X				X	X	X		X	X		X	
	Ambient temperature (inside & outside)			X			X	X	X		X	X		X	
	Complete machine - damage, loose parts & earth bonds		X				X	X	X		X	X		X	
	Guards, screens, warning and safety labels		X				X	X	X		X	X		X	
	Maintenance access		X				X								
	Electrical nominal operating conditions & excitation	X		X			X	X	X		X	X		X	
	Vibration	X		X			X	X	X		X	X		X	
Windings	Condition of windings		X				X	X	X		X	X		X	
	Insulation resistance of all windings (PI test for MV/HV)			X			X	*	*		X	X		X	
	Insulation resistance of rotor, exciter and PMG			X				X	X						
	Temperature sensors	X		X			X	X	X		X	X		X	
	Customer settings for temperature sensors		X				X								

System	SERVICE ACTIVITY  X = required * = if necessary	Alternator running	TYPE				SERVICE LEVEL							
			Inspect	Test	Clean	Refill/Replace	Commission	Post Commission	250 hrs / 0.5 year	Level 1	1000 hrs / 1 year	Level 2	10,000 hrs / 2 years	Level 3
Bearings	Condition of bearings		X				X							X
	Grease exhaust & trap				X			every 4000 hours						
	Re-grease re-greasable bearing(s) (where Auto Re-greaser not fitted)	X				X		every 1000 to 1500 hours / 6 months						
	Refill grease reservoir. Do not exceed 'Max' filling mark. (where Auto Re-greaser fitted)					X		every 8000 hours						
	Replace re-greasable bearing(s)					X					*		X	
	Temperature sensors	X		X			X	X	X	X	X	X	X	
	Customer settings for temperature sensors		X				X							
Terminal Box	All alternator/customer connections and cabling		X				X	X	X	X	X	X		
Controls & Auxiliaries	Initial AVR & PFC set up	X		X			X							
	AVR & PFC settings	X		X				X	X	X	X	X		
	Customer connection of auxiliaries			X			X		X	X	X	X		
	Function of auxiliaries			X			X	X	X	X	X	X		
	Synchronization settings		X				X							
	Synchronization	X		X			X	X	X	X	X	X		
	Anti condensation heater					X					*	X		
Rectifier	Diodes, varistors and resistors		X				X	X	X	X	X			
	Diodes, varistors and resistors					X						X		

System	SERVICE ACTIVITY  X = required * = if necessary	Alternator running	TYPE				SERVICE LEVEL							
			Inspect	Test	Clean	Refill/Replace	Commission	Post Commission	250 hrs / 0.5 year	Level 1	1000 hrs / 1 year	Level 2	10,000 hrs / 2 years	Level 3
Cooling	Air inlet temperature	X		X			X	X		X	X			X
	Air flow (rate & direction)	X	X				X							
	Condition of fan		X				X	X		X	X			X
	Condition of air filter (where fitted)			X			X	X		X	X			X
	Air filters (where fitted)					X	X			*	*			*

## 7.2 Bearings

### 7.2.1 Introduction

NOTICE
<p>Do not overfill a bearing with grease; the bearing may be damaged.</p> <p>Do not mix lubricant types. Change gloves to handle different lubricant</p> <p>Assemble bearings in static- and dust-free conditions while wearing lint free gloves.</p> <p>Store removed parts and tools in static- and dust-free conditions, to prevent damage or contamination.</p> <p>A bearing is damaged by the axial force needed to remove it from the rotor shaft. Do not reuse a bearing.</p> <p>A bearing is damaged if the insertion force is applied through the bearing balls. Do not press fit the outer race by force on the inner race, or vice versa.</p> <p>Do not try to turn the rotor by levering against the cooling fan vanes. The fan will be damaged.</p>

The alternator rotor is supported by a bearing at the non-drive end (NDE) and by either a bearing or a coupling to the prime mover at the drive end (DE).

- Lubricate each re-greasable bearing according to the recommended service schedule with the correct quantity and type of grease, also shown on a label fitted at the grease nipple.

### 7.2.2 Safety

⚠ DANGER
<p><b>Rotating Mechanical Parts</b></p> <p>Rotating mechanical parts can cause serious injury or death by crushing, severing or trapping.</p> <p>To prevent injury and before removing covers over rotating parts, isolate the generator set from all energy sources, remove stored energy and use lock out/tag out safety procedures.</p>

**⚠ WARNING**

**Hot Surfaces**

Skin contact with hot surfaces can cause serious injury by burns.  
To prevent injury, wear appropriate personal protection equipment (PPE).

**⚠ CAUTION**

**Grease**

Skin contact with grease can cause minor or moderate injury by contact dermatitis.  
To prevent injury, wear appropriate personal protection equipment (PPE).

**NOTICE**

Do not overfill a bearing with grease; the bearing may be damaged.  
Do not mix lubricant types. Change gloves to handle different lubricant  
Assemble bearings in static- and dust-free conditions while wearing lint free gloves.  
Store removed parts and tools in static- and dust-free conditions, to prevent damage or contamination.  
A bearing is damaged by the axial force needed to remove it from the rotor shaft. Do not reuse a bearing.  
A bearing is damaged if the insertion force is applied through the bearing balls. Do not press fit the outer race by force on the inner race, or vice versa.  
Do not try to turn the rotor by levering against the cooling fan vanes. The fan will be damaged.

## 7.2.3 Re-grease Bearings

### 7.2.3.1 Requirements

Personal Protective Equipment (PPE)	Wear mandatory site PPE
Consumables	Lint-free cleaning cloths
	Thin disposable gloves
Parts	CGT recommended grease
Tools	Grease gun (calibrated for volume or mass)

### 7.2.3.2 Automatic Re-grease

If the automatic bearing re-greaser is fitted (see [Section 7.2.3.4 on page 37](#)), manual re-greasing is not required.

### 7.2.3.3 Re-grease Method

**TABLE 9. REGREASING: GREASE QUANTITY**

Bearing Type	Quantity of recommended grease	
	Volume (cm <sup>3</sup> )	Mass (g)
Drive End (P80 Core length R, S, T)	<b>136</b>	<b>121</b>
Drive End (P80 Core length W, Y, Z)	<b>195</b>	<b>173</b>
Non-drive End (P80 All core lengths)	<b>170</b>	<b>151</b>

1. For each bearing, identify grease nipple, re-greasing label and bearing type.
2. Make sure the new grease is not contaminated. It must be a uniform whitish-beige colour of stiff consistency throughout.

3. Clean the grease gun nozzle and grease nipple.
4. Remove the grease exhaust grommet and let excess grease escape.
5. Clean the grease exhaust.
6. Where an air filter is fitted, with the alternator stopped, remove the air filter and clean the exhausted grease trap. Afterwards, replace the air filter.
7. With the alternator running, fit the grease gun to the grease nipple and add the correct quantity of grease.
8. Run the alternator for at least 60 minutes, off- or on-load.
9. Clean the grease exhaust and re-fit grommet.
10. Inspect the colour and consistency of grease expelled from the exhaust and compare with new grease - whitish-beige of stiff consistency.
11. Replace the bearing if the expelled grease is severely discoloured or absent.

**NOTICE**

**If the exhaust grease trap overflows, the stator and rotor windings would be contaminated. Make sure trap is emptied when re-greasing.**

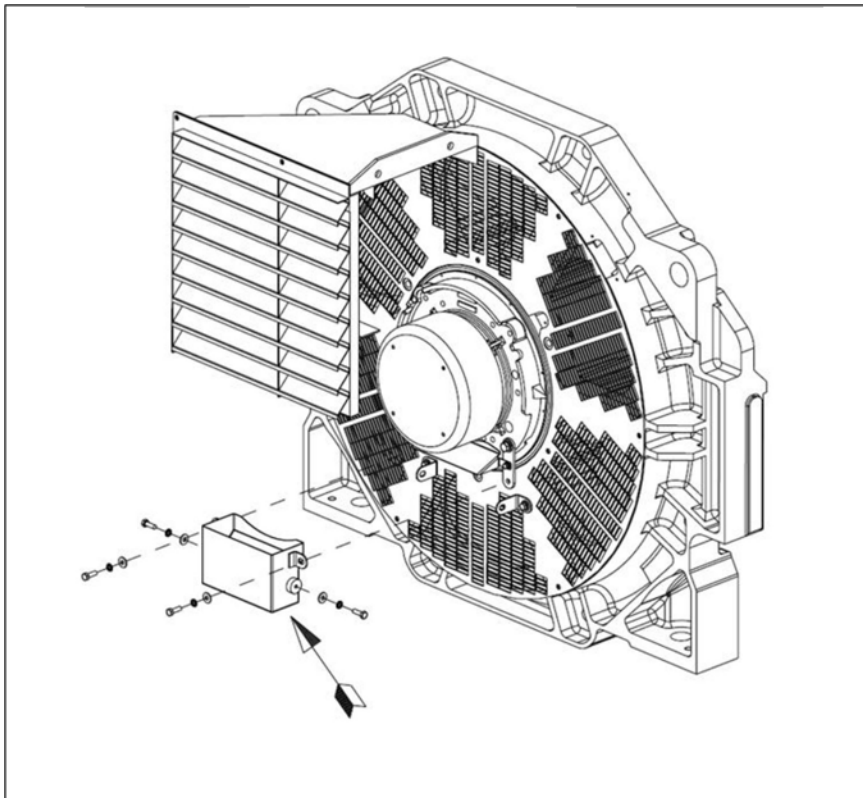

**FIGURE 8. GREASE TRAP ON P80 ALTERNATORS WITH AN AIR FILTER**



### 7.2.3.4 Automatic Alternator Bearing Regreaser

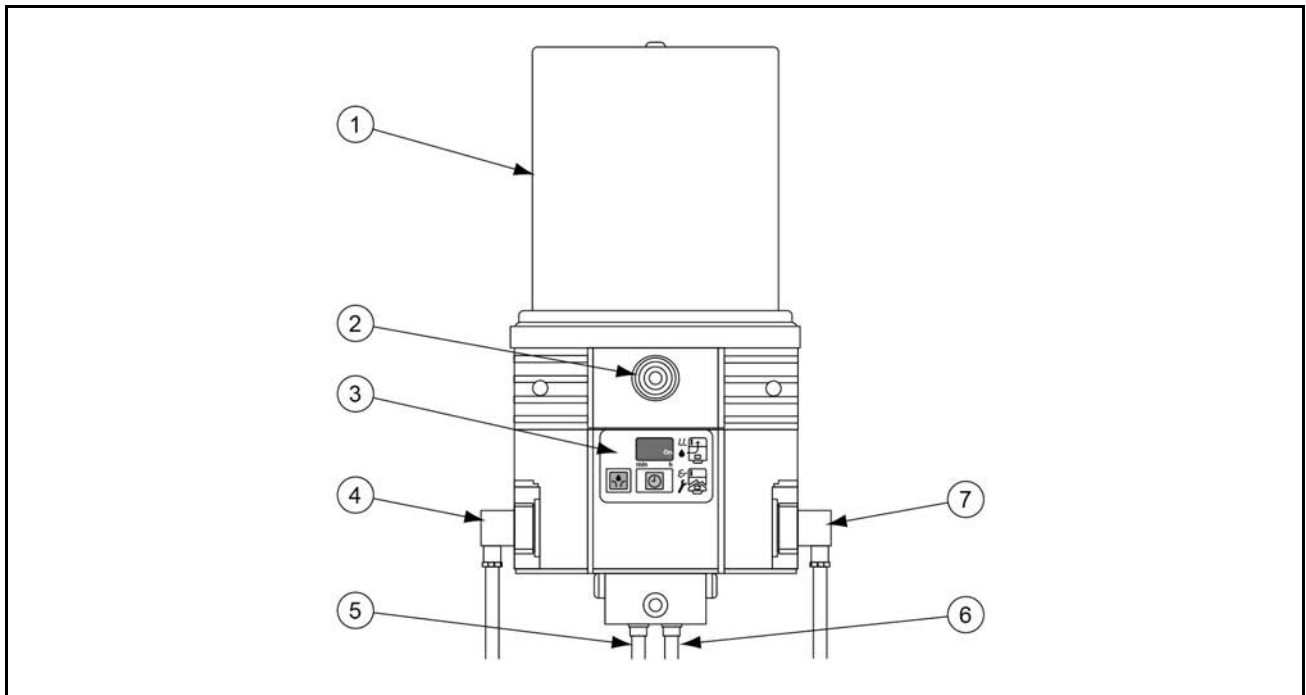

No	Description	No	Description
1	Grease reservoir	5	Grease Line
2	Grease fill point	6	Grease Line
3	Control panel	7	Remote Control Harness
4	Power Supply Cable		

**FIGURE 9. TYPICAL AUTOMATIC ALTERNATOR BEARING REGREASER**

The alternator may be fitted with an automatic bearing regreaser. The timing settings for grease application has been set at the factory.

When refilling the grease reservoir only use the grease stated (Kluberquiet BQ 72-72).

### 7.2.3.5 Automatic Alternator Bearing Regreaser - Operation

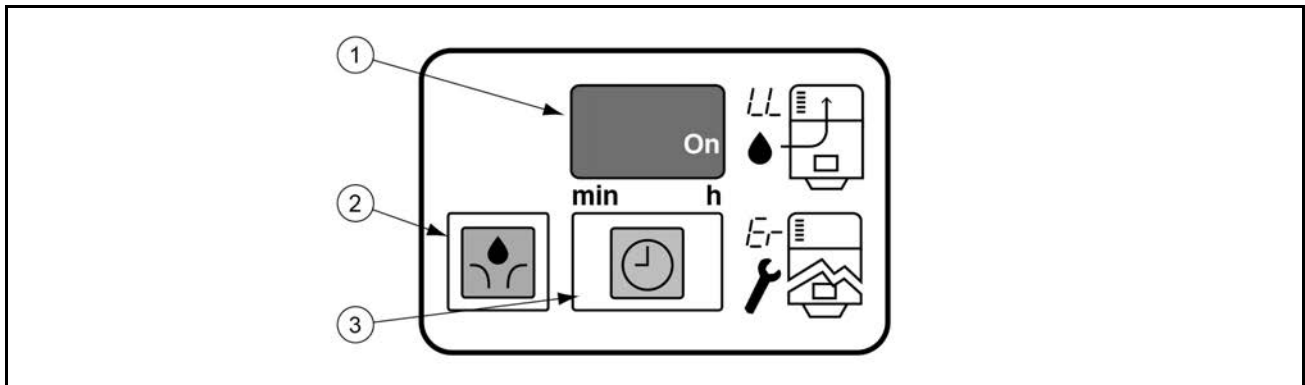

No	Description	No	Description
1	Display		
2	Operator button		
3	Operator button (Timer settings)		

The timing for grease application has been set at the factory.

**FIGURE 10. CONTROL PANEL**

**NOTICE**

Refill the grease reservoir according to the service schedule. Do not fill above the 'max' level marked on the reservoir. Use only Kluberquiet BQ 72-72 grease. Do not mix grease types.

**TABLE 10. CONTROL PANEL DISPLAY MESSAGES**

Display	Description
	The display shows a lit green bar to indicate the pause time is running (between dispenses). Auto re-greaser is between re-grease events.
	Pump running is indicated by rotating light movements on the display.
	An error message is displayed if the reservoir is empty.
	An error message is displayed if a fault occurs.

To acknowledge a fault (grease reservoir empty):

1. Press the operator button (2) to acknowledge the fault. The message (flashing) changes to continuous lit.
2. Fill the reservoir using Kluberquiet BQ 72-72 grease.
3. Press the operator button (2) (for 2 seconds) to trigger lubrication cycles until the indicator pin (control pin) moves across the proximity switch. See [Figure 11](#).

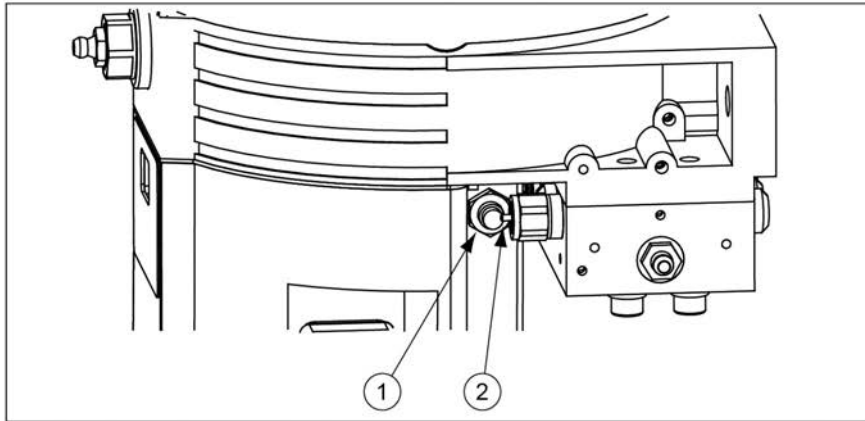

**FIGURE 11. PROXIMITY SWITCH (1) AND CONTROL PIN (2)**

### 7.2.3.6 Automatic Re-greaser - Settings

The alternator may be fitted with an automatic bearing regreaser. The settings for grease application have been set at the factory.

**NOTICE**

**Do not change the automatic re-greaser settings.**

**TABLE 11. AUTOMATIC RE-GREASER: SETTINGS**

Parameter	P1 Pause time (hours)	P2 Pause time (mins)	P3 Number of cycles (n)	P4 Fault relay contact (no/nc)	P5 External fault display	P6 Start phase (SP/SO)
Value	20	00	3	nc	-u	SP

## 7.3 Controls

### 7.3.1 Introduction

An operating alternator is a harsh environment for control components. Heat and vibration can cause electrical connections to loosen and cables to fail. Routine inspection and test can identify an issue before it becomes a failure that incurs unplanned downtime.

## 7.3.2 Safety

 <b>DANGER</b>
<b>Live Electrical Conductors</b> Live electrical conductors can cause serious injury or death by electric shock and burns. To prevent injury and before removing covers over electrical conductors, isolate the generator set from all energy sources, remove stored energy and use lock out/tag out safety procedures.

 <b>WARNING</b>
<b>Hot Surfaces</b> Skin contact with hot surfaces can cause serious injury by burns. To prevent injury, wear appropriate personal protection equipment (PPE).

## 7.3.3 Requirements

Personal Protective Equipment (PPE)	Wear mandatory site PPE
Consumables	None
Parts	None
Tools	Multimeter
	Torque wrench

## 7.3.4 Inspect and Test

1. Remove the terminal box lid
2. Check the tightness of M12 fasteners securing the load cables.
3. Check that cables are firmly clamped at the terminal box gland, and allow  $\pm 25$  mm movement by an alternator on anti-vibration mounts.
4. Check that all cables are anchored and unstressed within the terminal box.
5. Check all cables for signs of damage caused by vibration, including insulation wear and wire strand breaks.
6. Check that all AVR accessories and current transformers are correctly fitted, and cables pass centrally through current transformers.
7. Isolate the anti-condensation heater supply and measure electrical resistance of the heater element(s). Replace heater element if open circuit.
8. Test the supply voltage to the anti-condensation heaters (if fitted). 100 VAC to 138 VAC. should be present across each heater element when the alternator is stopped. Refer to the wiring diagram for heater connections.
9. Check that AVR and AVR accessories within the terminal box are clean, securely fitted on anti-vibration mounts, and the cable connectors are firmly attached to the terminals. AVR and AVR accessories do not need further routine servicing.
10. For parallel operation, check that alternator frequency signal cables to the synchronization equipment are securely connected.
11. Refit the terminal box lid.

---

## 7.4 Cooling System

### 7.4.1 Introduction

The alternators are designed to meet standards supporting EU Safety Directives, and are rated for the effect of operating temperature on winding insulation.

**BS EN 60085 (≡ IEC 60085) Electrical insulation – Thermal Evaluation and Designation** classifies insulation by the maximum operating temperature for a reasonable service life. Although chemical contamination and electrical and mechanical stresses also contribute, temperature is the dominant aging factor. Fan cooling maintains a stable operating temperature below the insulation class limit.

If the operating environment differs from the values shown on the rating plate, rated output must be reduced by

- 3% for class H insulation for every 5 °C that the temperature of the ambient air entering the cooling fan exceeds 40 °C, up to a maximum of 60 °C
- 3.5% for class F insulation for every 5 °C that the temperature of the ambient air entering the cooling fan exceeds 40 °C, up to a maximum of 60 °C
- 4.5% for class B insulation for every 5 °C that the temperature of the ambient air entering the cooling fan exceeds 40 °C, up to a maximum of 60 °C
- 3% for every 500 m increase in altitude above 1000 m, up to 4000 m, due to the reduced thermal capacity of lower density air, and
- 5% if air filters are fitted, due to restricted air flow.

Efficient cooling depends on maintaining the condition of the cooling fan, air filters and gaskets.

### 7.4.2 Safety

#### **DANGER**

##### **Rotating Mechanical Parts**

Rotating mechanical parts can cause serious injury or death by crushing, severing or trapping.

To prevent injury and before removing covers over rotating parts, isolate the generator set from all energy sources, remove stored energy and use lock out/tag out safety procedures.

#### **WARNING**

##### **Hot Surfaces**

Skin contact with hot surfaces can cause serious injury by burns.

To prevent injury, wear appropriate personal protection equipment (PPE).

#### **CAUTION**

##### **Dust**

Inhaling dust can cause minor or moderate injury by irritating the lungs. Dust can cause minor or moderate injury by irritating the eyes.

To prevent injury, wear appropriate personal protection equipment (PPE). Ventilate the area to disperse dust.

#### **NOTICE**

Do not attempt to rotate the alternator rotor by levering against the vanes of the cooling fan. The fan is not designed to withstand such forces and will be damaged.

---

**NOTICE**

**Filters are designed to remove dust, not moisture. Wet filter elements can cause reduced air flow and overheating. Do not allow filter elements to get wet.**

### 7.4.3 Requirements

Personal Protective Equipment (PPE)	Wear mandatory site PPE
	Wear eye protection
	Wear respiratory protection
Consumables	Lint-free cleaning cloths
	Thin disposable gloves
Parts	Air filters (if fitted)
	Air filter sealing gaskets (if fitted)
Tools	None

### 7.4.4 Inspect and Clean

**NOTICE**

**A sensor detects the differential pressure caused by blocked filters. If the sensor trips, inspect and clean the air filters more frequently.**

1. Remove the fan screen.
2. Inspect the fan for damaged vanes and cracks.
3. Remove air filters (at the fan and terminal box, if fitted) from their frames.
4. Wash and dry the air filters and gaskets to remove contaminant particles.
5. Inspect the filters and gaskets for damage and replace, as necessary.
6. Install the filters and gaskets.
7. Re-install the fan screen.
8. Reinstall the generator set for running.
9. Make sure the air inlets and outlets are not blocked.

## 7.5 Coupling

### 7.5.1 Introduction

Efficient operation and long component life rely on minimizing mechanical stresses on the alternator. When coupled in a generator set, misalignment and vibration interactions with the prime mover engine can cause mechanical stress.

The rotational axes of alternator rotor and engine output shaft must be coaxial (radial and angular alignment).

Torsional vibration can cause damage to internal combustion engine shaft-driven systems, if not controlled. The generator set manufacturer is responsible for assessing the effect of torsional vibration on the alternator: Rotor dimensions and inertia, and coupling details are available on request.

## 7.5.2 Safety

### NOTICE

Do not attempt to rotate the alternator rotor by levering against the vanes of the cooling fan. The fan is not designed to withstand such forces and will be damaged.



## 7.5.3 Requirements

Personal Protective Equipment (PPE)	Wear mandatory site PPE
Consumables	None
Parts	None
Tools	Dial gauge Torque wrench

## 7.5.4 Inspect Mounting Points

1. Check the generator set bedplate and mounting pads are in good condition, not cracked
2. Check that rubber in anti-vibration mounts has not perished
3. Check vibration monitoring historical records for a trend of increasing vibration

### 7.5.4.1 Single Bearing Coupling

1. Remove the DE adapter screen and cover to access the coupling
2. Check that the coupling discs are not damaged, cracked or distorted, and the coupling disc holes are not elongated. If any are damaged, replace the complete set of discs.
3. Check tightness of bolts fixing the coupling discs to the engine flywheel. Tighten in the sequence shown for alternator coupling in the Installation chapter, to the torque recommended by the engine manufacturer.
4. Replace the DE adapter screen and drip proof cover.

---

## 7.6 Rectifier System

### 7.6.1 Introduction

The rectifier converts alternating current (a.c.) induced in the exciter rotor windings into direct current (d.c.) to magnetise the main rotor poles. The rectifier comprises two semicircular annular positive and negative plates, each with three diodes. In addition to connecting to the main rotor, the dc output of the rectifier also connects to a matched pair of varistors (one at each end of the plates) and two pairs of resistors (mounted into holes in the exciter rotor). These additional components protect the rectifier from voltage spikes and surge voltages that may be present on the rotor under various loading conditions of the alternator.

Diodes provide a low resistance to current in one direction only: Positive current will flow from anode to cathode, or another way of viewing it is that negative current will flow from cathode to anode.

The exciter rotor windings are connected to 3 diode anodes to form the positive plate and to 3 diode cathodes to form the negative plate to give full wave rectification from a.c. to d.c. The rectifier is mounted on, and rotates with, the exciter rotor at the non-drive end (NDE).

### 7.6.2 Safety

 <b>DANGER</b>	
<b>Live Electrical Conductors</b>	<b>Live electrical conductors can cause serious injury or death by electric shock and burns. To prevent injury and before removing covers over electrical conductors, isolate the generator set from all energy sources, remove stored energy and use lock out/tag out safety procedures.</b>

 <b>DANGER</b>	
<b>Rotating Mechanical Parts</b>	<b>Rotating mechanical parts can cause serious injury or death by crushing, severing or trapping. To prevent injury and before removing covers over rotating parts, isolate the generator set from all energy sources, remove stored energy and use lock out/tag out safety procedures.</b>

### 7.6.3 Requirements

Personal Protective Equipment (PPE)	Wear appropriate PPE.
Consumables	Loctite 242 thread locking adhesive
	Midland silicone heat sink compound type MS2623 or similar
	Duralco 4461N Amber Electrically Resistant Epoxy [Part: 030-02668]
	Vidaflex 942 acrylic 3mm sleeving [Part: 030-01548]
	Vidaflex 942 acrylic 5mm sleeving [Part: 030-01550]
	Sumitube B2 polyolefin heat shrink 9.5mm tubing [Part: 030-04179]



Parts	Kit of three anode lead diodes and three cathode lead diodes (all from the same manufacturer)
	Kit of two metal-oxide varistors (same type, same manufacturer, same voltage grading: A, B, C, D, E, F)
	Kit of four snubber resistors (same type, same manufacturer)
Tools	Multimeter
	Insulation Tester
	Torque wrench
	Resistor removal tool
	Hammer
	Round file

## 7.6.4 Test and Replace Resistors

1. Inspect the visible ends of all four resistors.
2. Resistor is faulty if there are any signs of discolouration or overheating.
3. Break the electrical circuit by removing fasteners from one resistor of each pair. Store fasteners and washers.
4. Measure the total resistance of both resistor pairs, using the ohms range of a digital multimeter.
5. Resistors are faulty if the total resistance of a resistor pair is outside the range  $100 \Omega \pm 10 \%$ .
6. If resistors are faulty, replace all four resistors:
  - a. Remove the fasteners from the existing resistors.
  - b. Label and disconnect the six exciter rotor winding leads at the insulated terminal posts.
  - c. Label and disconnect the two main rotor winding leads at the terminals on the rectifier plate.
  - d. Disconnect a lead from both varistors to allow the rectifier plates to be removed separately.
  - e. Note the rotational position of the rectifier plates. Use a 5 mm Allen key to remove four M6 x 120 fasteners and both plates (complete with diodes) from the exciter rotor.
  - f. Cut the leads and connecting the bases of both resistor pairs.
  - g. Remove each resistor:
    - a. Resistors may disintegrate during removal. Position covers and vacuum extraction to collect any ceramic fragments.
    - b. At the NDE, align the cylindrical removal tool squarely over the threaded terminal and onto the ceramic body of the resistor.
    - c. Strike the free end of the tool sharply with a hammer to break the glue seal and then drive the resistor out of the hole towards the drive end.
  - h. Use a round file to remove resin from the rotor core holes. Clean with a lint-free cloth.
  - i. Loose fit a replacement resistor into each cleaned hole to check that all resin has been removed.

- j. Apply 2 gm of epoxy and insert a replacement resistor into a rotor core hole, threaded post towards the rectifier plate position. Rotate the resistor to coat its surface evenly. Position the resistor so its base protrudes 3 mm from the core.
- k. Repeat with the remaining three replacement resistors.
- l. Leave the epoxy to cure.
- m. Fit a nut and a spring and flat washer on the M6 threaded post of each resistor.
- n. Refit the complete rectifier assembly onto the exciter rotor.
- o. Apply thread lock and fit a flat washer and stover nut on the M6 threaded post of each resistor. Ensure good electrical contact with the rectifier plate.
- p. Refer to the images and the steps below to finish and secure the resistor leads.

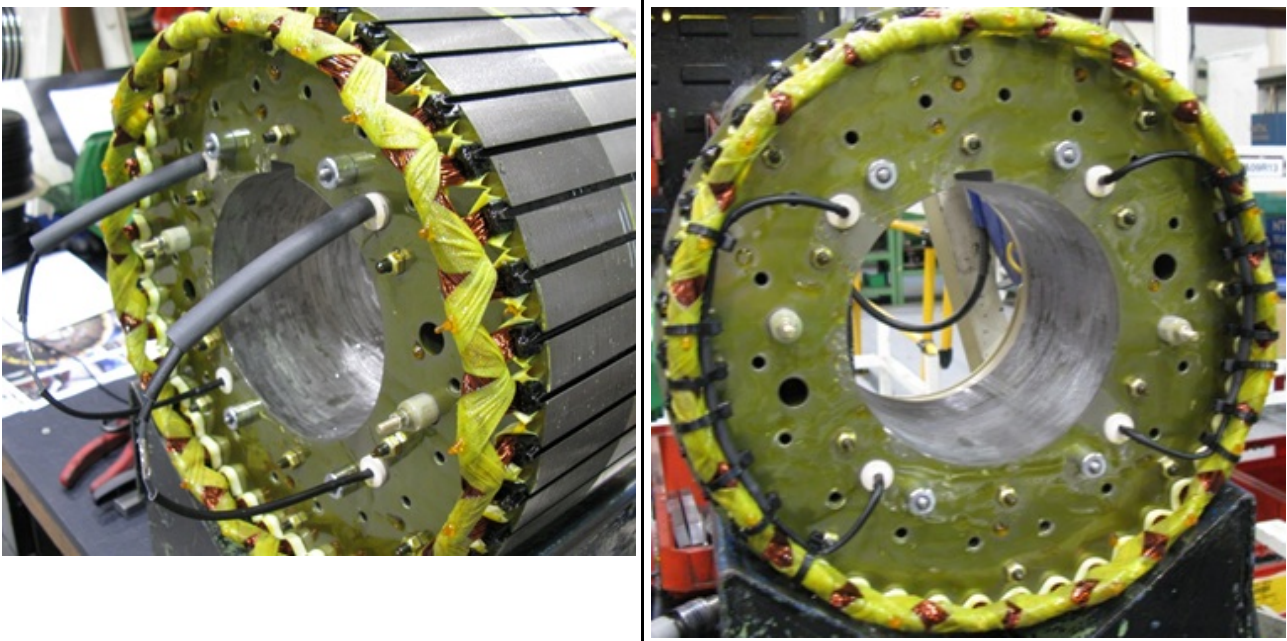

- q. Sleeve each resistor lead with 3 x 130 mm Vidaflex 942.
  - r. Sleeve two of the resistor leads (which are electrically connected through the rectifier plate) with 5 x 70 mm Vidaflex 942 and 9.5 x 100 mm heat shrink tubing (030-04179).
  - s. Connect by a crimped ferrule (003-09103) with the remaining resistor leads (electrically connected on the other rectifier plate) as shown.
  - t. Slide the 5 x 70 mm Vidaflex 942 and 9.5 x 100 mm heat shrink tubing over the ferrule and shrink the tube by heating.
  - u. Secure both lead assemblies to the inside of the exciter rotor windings with seven heat-stabilised cable ties (052-45017). Position the cable tie heads to the inside.
7. Replace both varistors with a matching pair (same type, same manufacturer and same voltage grading: A, B, C, D, E, F) (see below).
  8. Replace all diodes (see below).
  9. Reconnect and check that all leads are secure, washers fitted and fasteners tight.

## 7.6.5 Test and Replace Varistors

1. Inspect both varistors.

- 
2. Record varistor as faulty if there are signs of overheating (discoloration, blisters, melting) or disintegration. Check for loose connectors vs. varistor body.
  3. Disconnect one varistor lead. Store fastener and washers.
  4. Measure the resistance across each varistor. Good varistors have a resistance greater than 100 MΩ.
  5. Record varistor as faulty if the resistance is short circuit or open circuit in either direction.
  6. If either varistor is faulty, replace both varistors with a matched pair (same type, same manufacturer and same voltage grading: A, B, C, D, E, F) and replace all diodes.
  7. Reconnect and check that all leads are secure, washers fitted and fasteners tight.

## 7.6.6 Test and Replace Diodes

<b>NOTICE</b>
---------------

<b>Do not tighten a diode above the stated torque. The diode will be damaged.</b>
---

1. Disconnect the lead of one diode where it joins the windings at the insulated terminal post. Store fastener and washers.
2. Measure the voltage drop across the diode in the forward direction, using the diode test function of a multimeter.
3. Measure the resistance across the diode in the reverse direction, using the 1000 VDC test voltage of an insulation tester.
4. Diode is faulty if the voltage drop in the forward direction is outside the range 0.3 to 0.9 VDC, or the resistance is below 20 MΩ in the reverse direction.
5. Repeat the tests for the five remaining diodes.
6. If any diode is faulty, replace the full set of six diodes (same type, same manufacturer):
  - a. Remove diode(s).
  - b. Apply a small amount of heat sink compound **only** to the base of the replacement diode(s), not the threads.
  - c. Check polarity of diode(s).
  - d. Screw each replacement diode into a threaded hole in the rectifier plate.
  - e. Apply 2.6 to 3.1 Nm (23 to 27.4 in-lb) torque to give good mechanical, electrical and thermal contact.
  - f. Replace both varistors with a matched pair (same type, same manufacturer and same voltage grading: A, B, C, D, E, F)
7. Reconnect and check that all leads are secure, washers fitted and fasteners tight.

## 7.7 Temperature Sensors

### 7.7.1 Introduction

The alternators are designed to meet standards supporting EU Safety Directives, and recommended operating temperatures. Temperature sensors (where fitted) detect abnormal overheating of the main stator windings and bearing(s). Sensors are of two types - Resistance Temperature Detector (RTD) sensors, with three wires, and Positive Temperature Coefficient (PTC) thermistors, with two wires – which are connected to a terminal block in the auxiliary or main terminal box. The resistance of Platinum (PT100) RTD sensors increases linearly with temperature.

**TABLE 12. RESISTANCE ( $\Omega$ ) OF PT100 SENSOR BETWEEN 40 TO 180 °C**

Temperature (°C)		+1 °C	+ 2 °C	+3 °C	+ 4 °C	+ 5 °C	+ 6 °C	+ 7 °C	+ 8 °C	+ 9 °C
40.00	115.54	115.93	116.31	116.70	117.08	117.47	117.86	118.24	118.63	119.01
50.00	119.40	119.78	120.17	120.55	120.94	121.32	121.71	122.09	122.47	122.86
60.00	123.24	123.63	124.01	124.39	124.78	125.16	125.54	125.93	126.31	126.69
70.00	127.08	127.46	127.84	128.22	128.61	128.99	129.37	129.75	130.13	130.52
80.00	130.90	131.28	131.66	132.04	132.42	132.80	133.18	133.57	133.95	134.33
90.00	134.71	135.09	135.47	135.85	136.23	136.61	136.99	137.37	137.75	138.13
100.00	138.51	138.88	139.26	139.64	140.02	140.40	140.78	141.16	141.54	141.91
110.00	142.29	142.67	143.05	143.43	143.80	144.18	144.56	144.94	145.31	145.69
120.00	146.07	146.44	146.82	147.20	147.57	147.95	148.33	148.70	149.08	149.46
130.00	149.83	150.21	150.58	150.96	151.33	151.71	152.08	152.46	152.83	153.21
140.00	153.58	153.96	154.33	154.71	155.08	155.46	155.83	156.20	156.58	156.95
150.00	157.33	157.70	158.07	158.45	158.82	159.19	159.56	159.94	160.31	160.68
160.00	161.05	161.43	161.80	162.17	162.54	162.91	163.29	163.66	164.03	164.40
170.00	164.77	165.14	165.51	165.89	166.26	166.63	167.00	167.37	167.74	168.11
180.00	168.48									

PTC thermistors are characterised by a sudden increase in resistance at a reference “switching” temperature. Customer-supplied external equipment may be connected to monitor the sensors and generate signals to raise an alarm and to shutdown the generator set.

**BS EN 60085 (≡ IEC 60085) Electrical insulation – Thermal Evaluation and Designation** classifies insulation of windings by the maximum operating temperature for a reasonable service life. To avoid damage to windings, signals should be set, appropriate to the insulation class shown on the alternator rating plate.

**TABLE 13. ALARM AND SHUTDOWN TEMPERATURE SETTINGS FOR WINDINGS**

Windings insulation	Max. Continuous temperature (°C)	Alarm temperature (°C)	Shutdown temperature (°C)
Class B	130	120	140
Class F	155	145	165
Class H	180	170	190

To detect overheating of bearings, control signals should be set according to the following table.

**TABLE 14. ALARM AND SHUTDOWN TEMPERATURE SETTINGS FOR BEARINGS**

Bearings	Alarm temperature (°C)	Shutdown temperature (°C)
Drive end bearing	45 + maximum ambient	50 + maximum ambient
Non-drive end bearing	40 + maximum ambient	45 + maximum ambient

## 7.7.2 Safety

 <b>DANGER</b>
<p><b>Live Electrical Conductors</b>            Live electrical conductors can cause serious injury or death by electric shock and burns. To prevent injury and before removing covers over electrical conductors, isolate the generator set from all energy sources, remove stored energy and use lock out/tag out safety procedures.</p>

 <b>WARNING</b>
<p><b>Hot Surfaces</b>            Skin contact with hot surfaces can cause serious injury by burns. To prevent injury, wear appropriate personal protection equipment (PPE).</p>

## 7.7.3 Test RTD Temperature Sensors

1. Remove the auxiliary terminal box lid.
2. Identify the sensor leads at the terminal block and where each sensor is fitted
3. Measure the resistance between the white and each red wire of one sensor
4. Calculate the sensor temperature from the measured resistance
5. Compare calculated temperature with temperature indicated by external monitoring equipment (if available)
6. Compare alarm and shutdown signal settings (if available) with recommended settings
7. Repeat steps 3 to 7 for each sensor
8. Refit the auxiliary terminal box lid.
9. Contact Cummins Customer Service Help Desk to replace faulty sensors. Main stator RTD are not replaceable. Bearing RTD are replaceable.

## 7.7.4 Test PTC Temperature Sensors

1. Remove the auxiliary terminal box lid.
2. Identify the sensor leads at the terminal block and where each sensor is fitted.
3. Measure the resistance between the two wires.
4. Sensor is faulty if resistance shows open circuit (infinity  $\Omega$ ) or short circuit (zero  $\Omega$ ).
5. Repeat steps 3 to 5 for each sensor.
6. Stop the alternator and inspect the change in resistance as the stator winding cools.
7. Sensor is faulty if resistance does not change or change is not smooth.
8. Repeat step 8 for each sensor.

- 
9. Refit the auxiliary terminal box lid.
  10. Contact Cummins Customer Service Help Desk to replace faulty sensors.

## 7.8 Windings

### 7.8.1 High Voltage Test

#### NOTICE

Windings have been tested at high voltage during manufacture. Repeated high voltage tests may degrade the insulation and reduce operating life. If a further test is required at installation for customer acceptance, it must be done at a reduced voltage,  $V = 0.8 \times (2 \times \text{Rated Voltage} + 1000)$ . Once in service, any further tests for maintenance purposes must be done after passing visual checks and insulation resistance tests, and at a reduced voltage,  $V = (1.5 \times \text{Rated Voltage})$ .

### 7.8.2 Introduction

#### NOTICE

Disconnect all control wiring and customer load leads from alternator winding connections before conducting these tests.

#### NOTICE

The Automatic Voltage Regulator (AVR) contains electronic components which would be damaged by high voltage applied during insulation resistance tests. The AVR must be disconnected before doing any insulation resistance test. Temperature sensors must be grounded to earth before doing any insulation resistance test. Damp or dirty windings have a lower electrical resistance and could be damaged by insulation resistance tests at high voltage. If in doubt, test the resistance at low voltage (500 V) first.

Alternator performance depends on good electrical insulation of the windings. Electrical, mechanical and thermal stresses, and chemical and environmental contamination, cause the insulation to degrade. Various diagnostic tests indicate the condition of insulation by charging or discharging a test voltage on isolated windings, measuring current flow, and calculating the electrical resistance by Ohm's law.

When a DC test voltage is first applied, three currents can flow:

- **Capacitive Current:** To charge the winding to the test voltage (decays to zero in seconds),
- **Polarizing Current:** To align the insulation molecules to the applied electric field (decays to near-zero in ten minutes), and
- **Leakage Current:** Discharge to earth where the insulation resistance is lowered by moisture and contamination (increases to a constant in seconds).

For an insulation resistance test, a single measurement is made one minute after a DC test voltage is applied, when capacitive current has ended. For the polarization index test, a second measurement is made after ten minutes. An acceptable result is where the second insulation resistance measurement is at least double the first, because the polarization current has decayed. In poor insulation, where leakage current dominates, the two values are similar. A dedicated Insulation Tester takes accurate, reliable measurements and may automate some tests.

## 7.8.3 Safety

 <b>DANGER</b>
<b>Live Electrical Conductors</b> Live electrical conductors can cause serious injury or death by electric shock and burns. To prevent injury and before removing covers over electrical conductors, isolate the generator set from all energy sources, remove stored energy and use lock out/tag out safety procedures.

 <b>WARNING</b>
<b>Live Electrical Conductors</b> Live electrical conductors at the winding terminals after an insulation resistance test can cause serious injury or death by electric shock or burns. To prevent injury, discharge the windings by shorting to earth through an earthing rod for at least 5 minutes.

## 7.8.4 Requirements

Type	Description
Personal Protective Equipment (PPE)	Wear mandatory site PPE
Consumables	None
Parts	None
Tools	Insulation test meter
	Multimeter
	Milliohm Meter or Micro Ohmmeter
	Clamp Ammeter
	Infrared thermometer

## 7.8.5 Test the Electrical Resistance of Windings

1. Stop the alternator.
2. Verify the electrical resistance of the exciter field (stator) winding:
  - a. Disconnect the exciter field leads F1 and F2 from the AVR.
  - b. Measure and record the electrical resistance between F1 and F2 leads with a multimeter.
  - c. Reconnect the exciter field leads F1 and F2.
  - d. Make sure the fasteners are secure.
3. Verify the electrical resistance of the exciter armature (rotor) winding:
  - a. Mark the leads attached to diodes on one of the two rectifier plates.
  - b. Disconnect all exciter rotor leads from all diodes at the rectifier.
  - c. Measure and record the electrical resistance between pairs of marked leads (between phase windings). A specialist micro ohmmeter must be used.
  - d. Reconnect all exciter rotor leads to the diodes.
  - e. Make sure the fasteners are secure.

4. Verify the electrical resistance of the main field (rotor) winding:
  - a. Disconnect the two main rotor d.c. leads from the rectifier plates.
  - b. Measure and record the electrical resistance between the main rotor leads. A specialist micro ohmmeter must be used.
  - c. Reconnect the two main rotor d.c. leads to the rectifier plates.
  - d. Make sure the fasteners are secure.
5. Verify the electrical resistance of the main armature (stator) winding:
  - a. Disconnect the leads of the main stator from the output terminals.
  - b. Measure and record the electrical resistance between U1 and U2 leads and between U5 and U6 (if present). A specialist micro ohmmeter must be used.
  - c. Measure and record the electrical resistance between V1 and V2 leads and between V5 and V6 (if present). A specialist micro ohmmeter must be used.
  - d. Measure and record the electrical resistance between W1 and W2 leads and between W5 and W6 (if present). A specialist micro ohmmeter must be used.
  - e. Reconnect the leads to the output terminals, as before.
  - f. Make sure the fasteners are secure.
6. Verify the electrical resistance of the PMG armature (stator) winding:
  - a. Disconnect the three PMG output leads P2, P3 and P4 from the AVR.
  - b. Measure and record the electrical resistance between pairs of the PMG output leads, with a multimeter.
  - c. Reconnect the three PMG output leads P2, P3 and P4 to the AVR.
  - d. Make sure the fasteners are secure.
7. Refer to the Technical Data ([Chapter 9 on page 65](#)) to verify the measured resistances of all windings agree with the reference values.

## 7.8.6 Test the Insulation Resistance of Windings

### NOTICE

**The alternator must not be put into service until the minimum insulation resistance is achieved.**

**TABLE 15. TEST VOLTAGE AND MINIMUM ACCEPTABLE INSULATION RESISTANCE FOR NEW AND IN-SERVICE ALTERNATORS**

	Test Voltage (V)	Minimum Insulation Resistance at 1 minute ( $IR_{1min}$ ) ( $M\Omega$ )		Minimum Polarisation Index ( $PI = (IR_{10min}) / (IR_{1min})$ )
		New	In-service	
Low Voltage (LV) stator, up to 1 kV	1000	10	5	
Medium voltage (MV) stator, 1 to 4.16 kV (each phase)	2500	100	50	2
High Voltage (HV) stator, 4.16 to 13.8 kV (each phase)	5000	300	150	2
PMG stator	500	5	3	



	Test Voltage (V)	Minimum Insulation Resistance at 1 minute ( $IR_{1min}$ ) ( $M\Omega$ )		Minimum Polarisation Index ( $PI = (IR_{10min}) / (IR_{1min})$ )
		New	In-service	
Exciter stator	500	10	5	
Exciter rotor, rectifier & main rotor combined	1000	200	100	

1. Inspect the windings for mechanical damage or discoloration from overheating. Clean the insulation if there is hygroscopic dust and dirt contamination.
2. For Low Voltage (LV) main stators:
  - a. Disconnect the neutral to earth conductor (if fitted).
  - b. Connect together the three leads of all phase windings (if possible).
  - c. Apply the test voltage from the table between any phase lead and earth.
  - d. Measure the the insulation resistance after 1 minute ( $IR_{1min}$ ).
  - e. Discharge the test voltage with an earth rod for five minutes.
  - f. If the measured insulation resistance is less than the minimum acceptable value, dry the insulation, then repeat the method.
  - g. Reconnect neutral to earth conductor (if fitted).
3. For Medium Voltage (MV) and High Voltage (HV) main stators:
  - a. Separate the three neutral leads.
  - b. Connect together both ends of each phase winding (if possible).
  - c. Ground two phases to earth.
  - d. Apply the test voltage from the table between the non-grounded phase and earth.
  - e. Measure the insulation resistance after 1 minute ( $IR_{1min}$ ).
  - f. Measure the insulation resistance after 10 minutes ( $IR_{10min}$ ).
  - g. Discharge the test voltage with an earth rod for five minutes.
  - h. Calculate the polarization index ( $PI = (IR_{10min}) / (IR_{1min})$ )
  - i. Test the other two phases in turn.
  - j. If the equivalent insulation resistance or polarization index is less than the minimum acceptable values, dry the insulation, then repeat the method.
  - k. Remove the connections made for testing and reconnect the neutral leads.
4. For PMG and exciter stators, and combined exciter and main rotors:
  - a. Connect together both ends of the winding (if possible).
  - b. Apply the test voltage from the table between the winding and earth.
  - c. Measure the insulation resistance after 1 minute ( $IR_{1min}$ ).
  - d. Discharge the test voltage with an earth rod for five minutes.
  - e. If the measured insulation resistance is less than the minimum acceptable value, dry the insulation, then repeat the method.
  - f. Repeat the method for each winding.
  - g. Remove the connections made for testing.

---

## 7.8.7 Dry the Insulation

Use the methods below to dry the insulation of the main stator windings. To prevent damage as water vapor is expelled from the insulation, make sure the winding temperature does not increase faster than 5 °C per hour or exceed 90 °C.

Plot the insulation resistance graph to show when drying is complete.

### 7.8.7.1 Dry with Ambient Air

In many cases, the alternator can be dried sufficiently using its own cooling system. Disconnect the cables from the X+ (F1) and XX- (F2) terminals of the AVR so there is no excitation voltage supply to the exciter stator. Run the generator set in this de-excited state. Air must flow freely through the alternator to remove the moisture. Operate the anti-condensation heater (if fitted) to assist the drying effect of the air flow.

After drying is complete, re-connect the cables between the exciter stator and AVR. If the generator set is not put into service immediately, turn on the anti-condensation heater (if fitted) and retest the insulation resistance before use.

### 7.8.7.2 Dry with Hot Air

Direct the hot air from one or two 1 to 3 kW electrical fan heaters into the alternator air inlet. Make sure each heat source at least 300 mm away from the windings to avoid scorching or over-heating damage to the insulation. Air must flow freely through the alternator to remove the moisture.

After drying, remove the fan heaters and re-commission as appropriate.

If the generator set is not put into service immediately, turn on the anti-condensation heaters (where fitted) and retest the insulation resistance before use.

### 7.8.7.3 Plot IR Graph

Whichever method is used to dry out the alternator, measure the insulation resistance and temperature (if sensors fitted) of the main stator windings every 15 to 30 minutes. Plot a graph of insulation resistance, IR (y axis) against time, t (x axis).

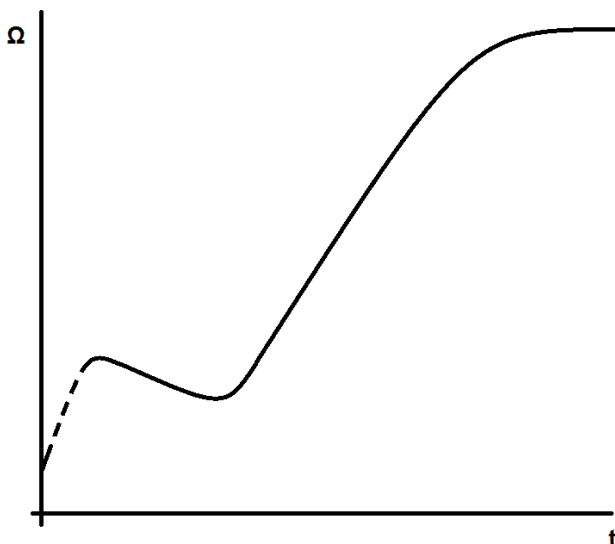

A typical curve shows an initial increase in resistance, a fall and then a gradual rise to a steady state; if the windings are only slightly damp the dotted portion of the curve may not appear. Continue drying for another hour after steady state is reached.

---

***NOTICE***

**The alternator must not be put into service until the minimum insulation resistance is achieved.**

---

This page is intentionally blank.

# 8 Parts Identification

## 8.1 PG80 Generator

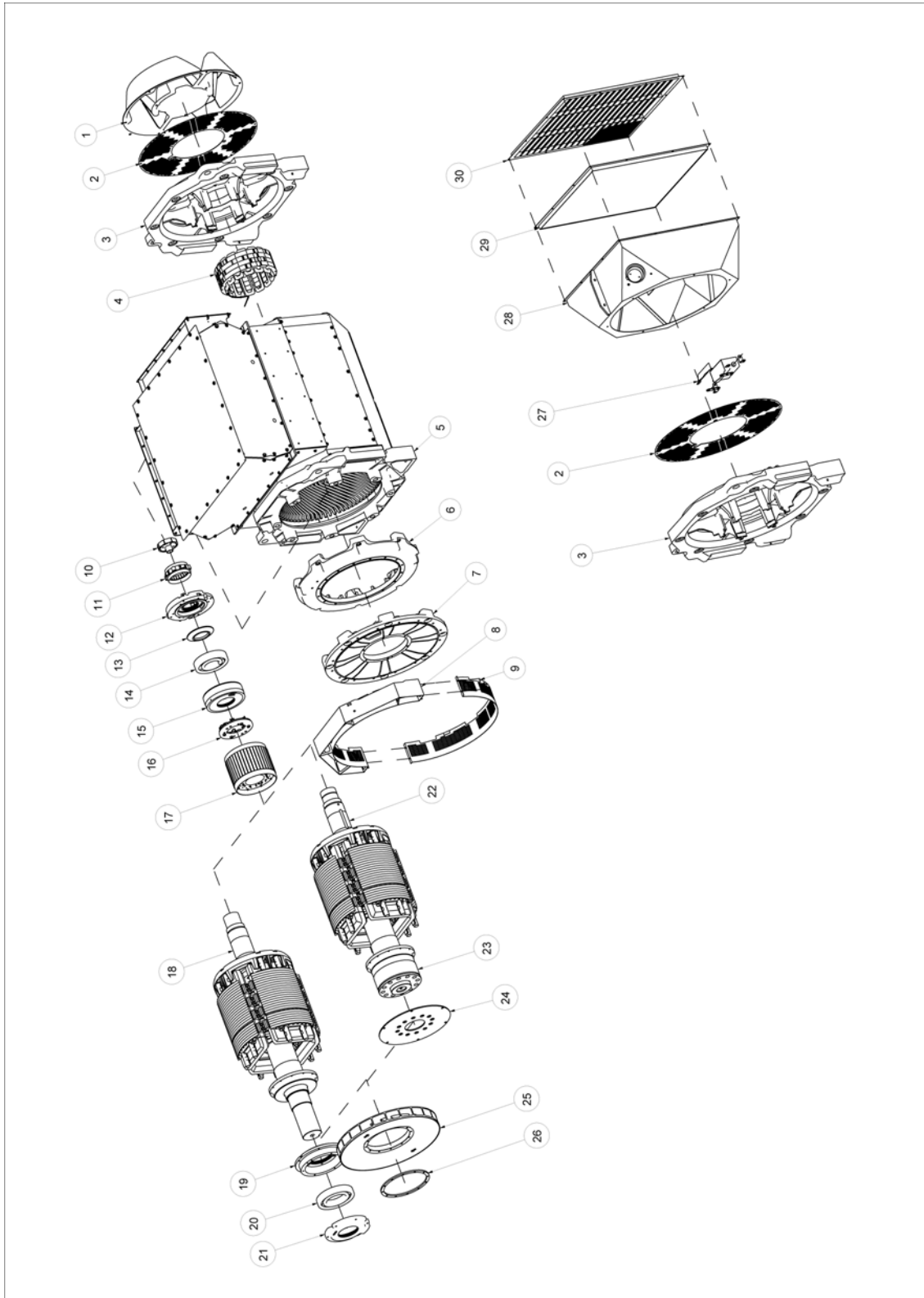

**TABLE 16. PG80 PARTS AND FASTENERS**

Reference	Component	Fastener	Number	Torque (Nm)
1	Air Inlet Cover	M8	9	8
2	Air Inlet Mesh	-	-	-
3	NDE Bracket (mass 295 kg)	M24	8	660
4	Exciter Stator	M8	6	22
5	DE Bracket	M24	8	660
6	DE Adapter (1 Bearing)	M24	8	660
7	DE Bearing Carrier (2 Bearing) (mass 111 kg)	M24	8	660
8	DE Air Outlet Upper Cover	M8	4	8
9	DE Air Outlet Lower Cover	-	-	-
10	PMG Rotor	M10	1	45
11	PMG Stator	M6	4	9.4
12	NDE Bearing Cap	M10	6	45
13	NDE Bearing Grease Flinger	-	-	-
14	NDE Bearing	-	-	-
15	NDE Bearing Cartridge	M10	6	45
16	Rectifier Assembly	-	-	-
17	Exciter Rotor	-	-	-
18	Rotor Assembly (2 Bearing)	-	-	-
19	DE Bearing Cartridge (2 Bearing)	M10	6	45
20	DE Bearing (2 Bearing)	-	-	-
21	DE Bearing Cap (2 Bearing)	M10	6	45
22	Rotor Assembly (1 Bearing)	-	-	-
23	DE Coupling Hub (1 Bearing)	-	-	-
24	Coupling Discs (1 Bearing)	M30	12	1350
25	Fan	-	-	-
26	Fan Clamp Ring	M10	12	31.5
27	Grease Trap Assembly	M8	4	8
28	Air Filter Inlet	M8	10	8
29	Air Filter Inlet Panel	-	-	-
30	Air Filter Inlet Louvre Cover	-	-	-

## 8.2 PG80 Rectifier

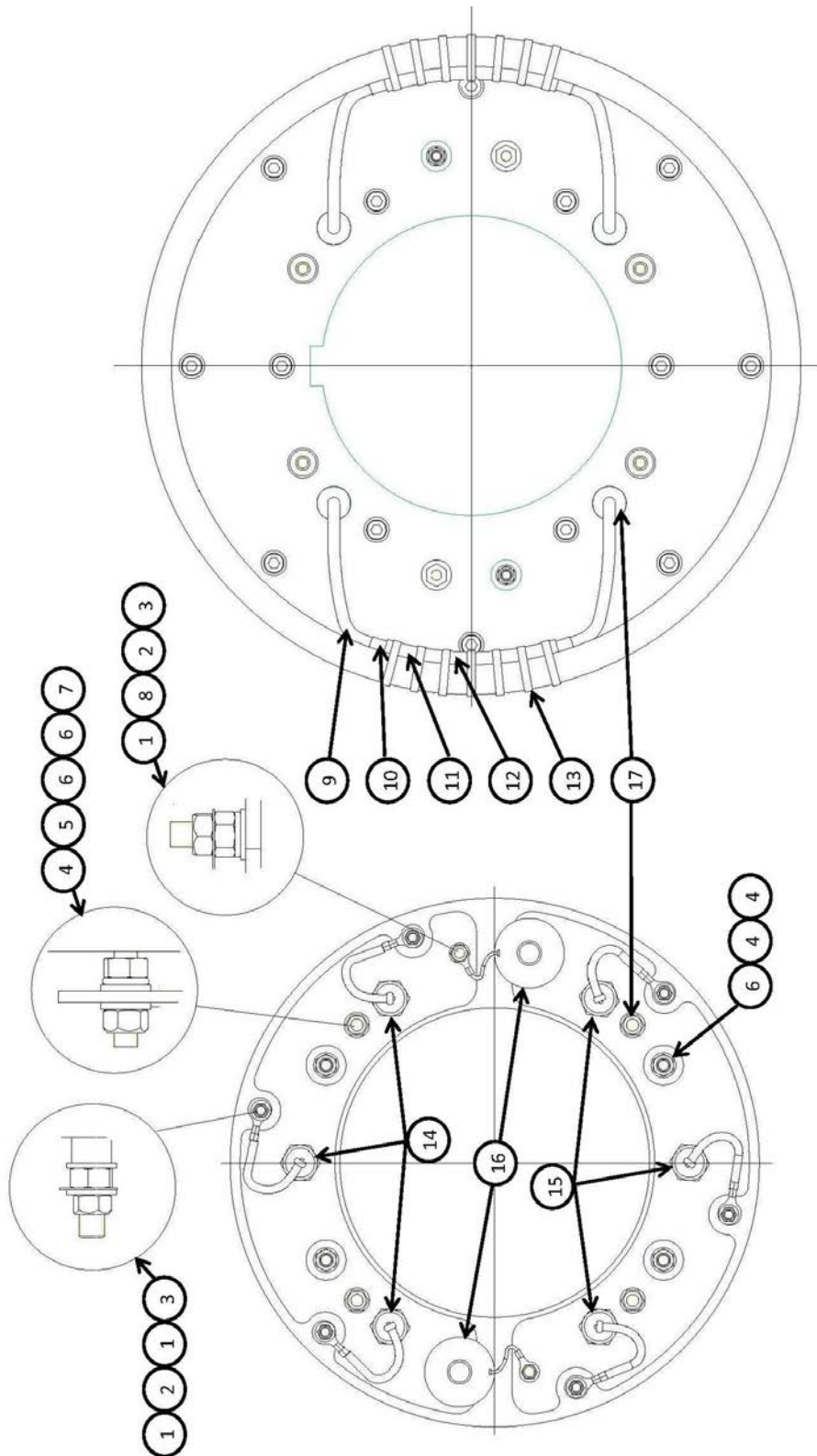
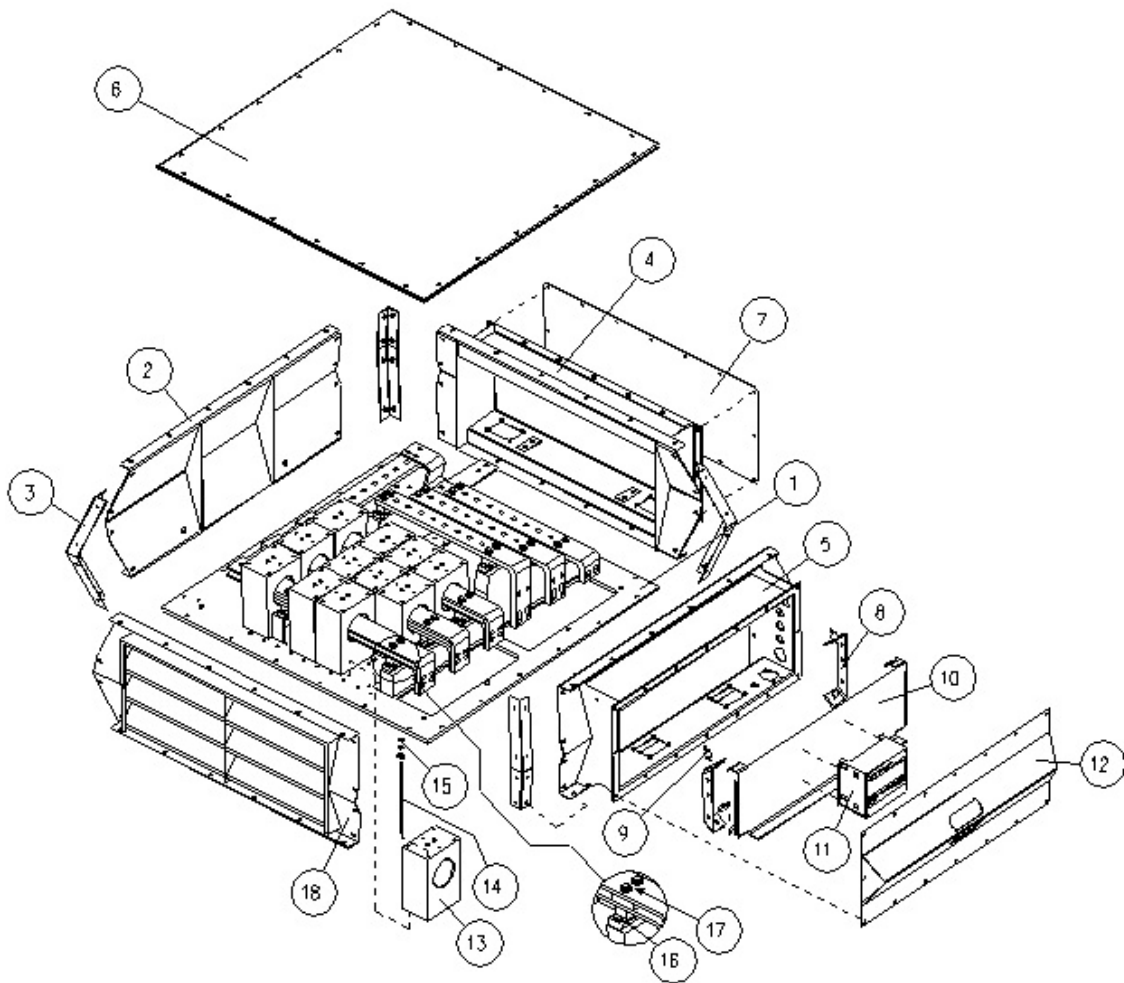

**TABLE 17. RECTIFIER COMPONENTS**

Reference	Component	Part	Quantity	Torque (Nm)
1	Flat Washer, M5	029-61106	14	-
2	Nut, M5	027-41206	8	-
3	Lock Nut, M5	006-01063	8	-
4	Nut, M6	027-41207	12	-
5	Spring Washer, M6	028-31507	4	-
6	Flat Washer, M6	029-61107	12	-
7	Lock Nut, M6	006-01051	4	-
8	Spring Washer, M5	028-31406	2	-
9	Sleeving	030-01548	2 x 130 mm	-
10	Sleeving	030-01550	1 x 70 mm	-
11	Heatshrink Sleeving	030-04179	1 x 130 mm	-
12	Butt Connector	003-09103	2	-
13	Cable Tie	052-45017	14	-
14	Diode (Forward)	730-10292	3	2.6 - 3.1
15	Diode (Reverse)	730-10293	3	2.6 - 3.1
16	Varistor with Lead	450-15075	2	-
17	Resistor	A040E410	4	



## 8.3 LV Terminal Box Parts and Fasteners

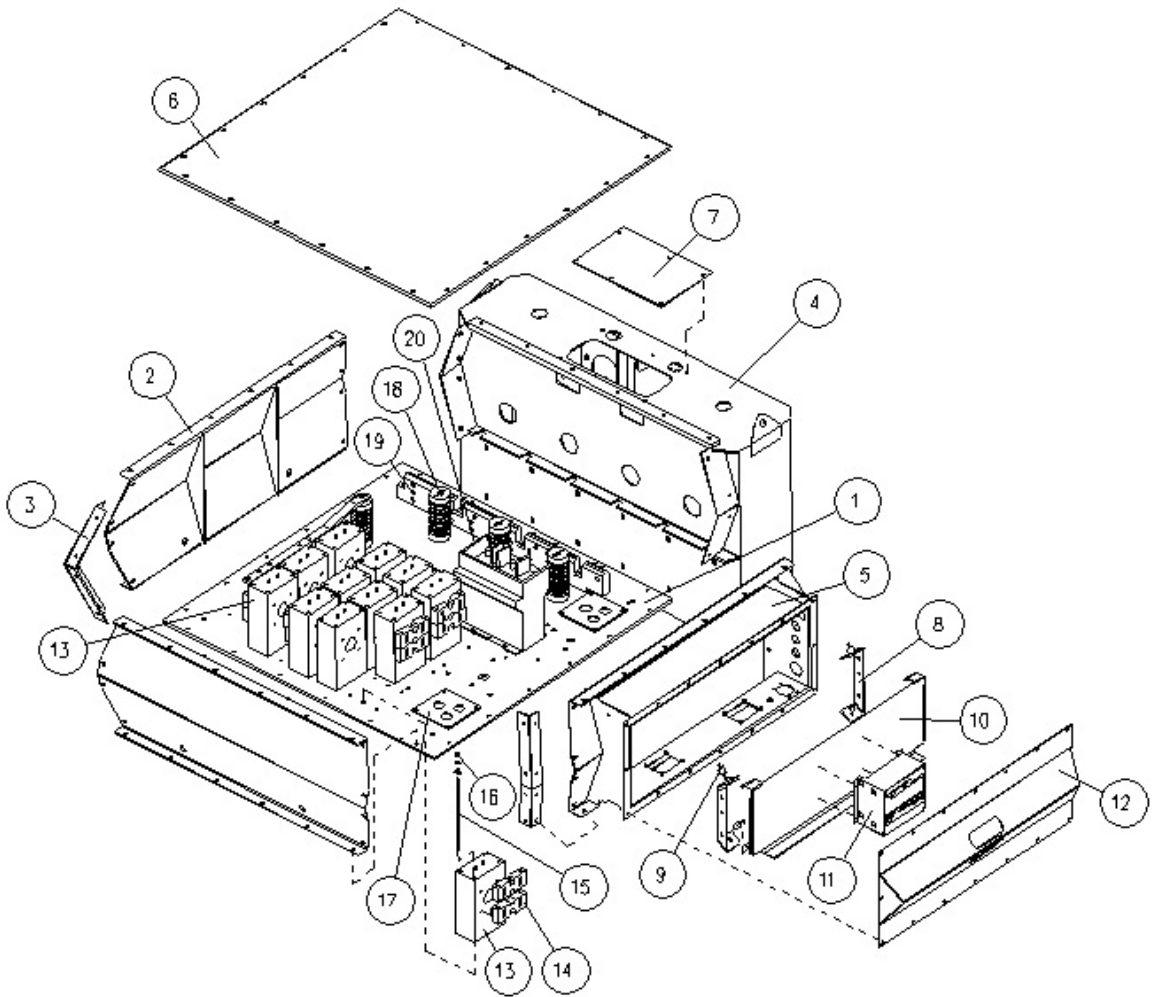

**TABLE 18. PARTS AND FASTENERS**

Reference	Component	Fastener	Torque (Nm)
1	Terminal Box Base Plate	-	-
2	Terminal Box End Panel - Drive End	-	-
3	Corner Piece	-	-
4	Connection Box	-	-
5	Auxilliary Terminal Box	-	-
6	Terminal Box Lid	-	-
7	Gland Plate	-	-
8	Anti-Vibration Mount Mounting Bracket	-	-
9	Anti-Vibration Mount (AVM)	-	-
10	Auxilliary Terminal Box Panel	-	-
11	Automatic Voltage Regulator (AVR) (typical arrangeent)	-	-
12	Auxilliary Terminal Box Cover	-	-
13	Current Transformer (CT)	-	-
14	CT Stud	-	-

Reference	Component	Fastener	Torque (Nm)
15	CT Nut	M8	22
16	Isolator Clamping Screw	M8	20
17	Bur Bar Fixing Screw	M8	30
18	Air Inlet Panel	-	-

## 8.4 MV/HV Terminal Box Parts and Fasteners



**TABLE 19. PARTS AND FASTENERS**

Reference	Component	Fastener	Torque (Nm)
1	Terminal Box Base Plate	M8 x 35	30
2	Terminal Box End Panel - Drive End	M8 x 25	30
3	Corner Piece	M8 x 25	30
4	Connection Box	M8 x 25	30
5	Auxilliary Terminal Box	M8 x 25	30
6	Terminal Box Lid	M8 x 25	30
7	Gland Plate	M6 x 16	12
8	Anti-Vibration Mount Mounting Bracket	M6	12

<b>Reference</b>	<b>Component</b>	<b>Fastener</b>	<b>Torque (Nm)</b>
9	Anti-Vibration Mount (AVM)	-	-
10	Auxilliary Terminal Box Panel	M8 x 25	30
11	Automatic Voltage Regulator (AVR)	M6 x 16	12
12	Auxilliary Terminal Box Cover	M8 x 25	30
13	Current Transformer (CT)	-	-
14	CT Stud	-	-
15	CT Nut	M8	22
16	Isolator Clamping Screw	M8 x 35	20
17	Gland Plate	M6 x 16	12
18	Post Insulator	M12	80
19	Cable Support	-	-
20	Isolating Transformer	M4	4

-

---

This page is intentionally blank.

# 9 Technical Data

## NOTICE

Compare measurements with the technical data sheet and the test certificate supplied with the alternator.

## 9.1 LV804 Parameters

Alternator	Frequency (Hz)	Voltage at terminals (V)					Resistance of windings at 20 °C				
		Phase to phase, L-L	Typical Residual		Normal		Exciter Stator (Ohms)	Exciter Rotor L-L (Ohms)	Main Rotor (Ohms)	Main Stator Phase to Neutral, L-N (milliOhms)	PMG Stator, L-L (Ohms)
			6,7,8 (E1, E2, E3)	Main, L-L	6,7,8	E1, E2, E3					
LV804R	50	400	35/60	60	190-250	400	17.5	0.076	1.32	0.67	3.8
	50	690	35	100	190-250	190-250	17.5	0.076	1.32	1.58	3.8
	60	480	35/70	70	190-250	480	17.5	0.076	1.32	0.67	3.8
	60	600	35/90	90	190-250	600	17.5	0.076	1.32	0.97	3.8
LV804S	50	400	35/60	60	190-250	400	17.5	0.076	1.40	0.54	3.8
	50	690	35	100	190-250	190-250	17.5	0.076	1.40	1.45	3.8
	60	480	35/70	70	190-250	480	17.5	0.076	1.40	0.54	3.8
	60	600	35/90	90	190-250	600	17.5	0.076	1.40	0.76	3.8
LV804T	50	400	35/60	60	190-250	400	17.5	0.076	1.50	0.44	3.8
	50	690	35	100	190-250	190-250	17.5	0.076	1.50	1.15	3.8
	60	480	35	70	190-250	480	17.5	0.076	1.50	0.44	3.8
	60	600	35/90	90	190-250	600	17.5	0.076	1.50	0.71	3.8

Alternator	Frequency (Hz)	Voltage at terminals (V)					Resistance of windings at 20 °C				
		Phase to phase, L-L	Typical Residual		Normal		Exciter Stator (Ohms)	Exciter Rotor L-L (Ohms)	Main Rotor (Ohms)	Main Stator Phase to Neutral, L-N (milliOhms)	PMG Stator, L-L (Ohms)
			6,7,8 (E1, E2, E3)	Main, L-L	6,7,8	E1, E2, E3					
LV804W	50	400	35/60	60	190-250	400	16	0.092	1.47	0.33	3.8
	50	690	35	100	190-250	190-250	16	0.092	1.47	0.88	3.8
	60	480	35/70	70	190-250	480	16	0.092	1.47	0.33	3.8
	60	600	35/90	90	190-250	600	16	0.092	1.47	0.48	3.8
LV804X	50	400	35/60	60	190-250	400	16	0.092	1.63	0.26	3.8
	60	480	35/70	70	190-250	480	16	0.092	1.63	0.26	3.8
	60	600	35/90	90	190-250	600	16	0.092	1.63	0.37	3.8
LV804Y	50	690	35	100	190-250	190-250	16	0.092	1.69	0.66	3.8

## 9.2 MV804 Parameters

Alternator	Frequency (Hz)	Voltage at terminals				Resistance of windings at 20 °C				
		Phase to phase, L-L (kV)	Typical Residual		Normal	Exciter Stator (Ohms)	Exciter Rotor, L-L (Ohms)	Main Rotor (Ohms)	Main Stator Phase to Neutral, L-N (Ohms)	PMG Stator, L-L (Ohms)
			6,7,8 (E1, E2, E3) (V)	Main, L-L (V)						
MV804R	50	3.3	35	500	190-250	17.5	0.076	1.32	0.0343	3.8
	60	4.16	35	650	190-250	17.5	0.076	1.32	0.0343	3.8
MV804S	50	3.3	35	500	190-250	17.5	0.076	1.40	0.0339	3.8
	60	4.16	35	650	190-250	17.5	0.076	1.40	0.0339	3.8

Alternator	Frequency (Hz)	Voltage at terminals				Resistance of windings at 20 °C				
		Phase to phase, L-L (kV)	Typical Residual		Normal	Exciter Stator (Ohms)	Exciter Rotor, L-L (Ohms)	Main Rotor (Ohms)	Main Stator Phase to Neutral, L-N (Ohms)	PMG Stator, L-L (Ohms)
			6,7,8 (E1, E2, E3) (V)	Main, L-L (V)						
MV804T	50	3.3	35	500	190-250	17.5	0.076	1.50	0.0286	3.8
	60	4.16	35	650	190-250	17.5	0.076	1.50	0.0286	3.8
MV804W	50	3.3	35	500	190-250	16	0.092	1.47	0.0194	3.8
	60	4.16	35	650	190-250	16	0.092	1.47	0.0194	3.8
MV804X	50	3.3	35	500	190-250	16	0.092	1.63	0.0154	3.8
	60	4.16	35	650	190-250	16	0.092	1.63	0.0154	3.8

## 9.3 HV804 Parameters

Alternator	Frequency (Hz)	Voltage at terminals				Resistance of windings at 20 °C				
		Phase to phase, L-L (kV)	Typical Residual		Normal	Exciter Stator (Ohms)	Exciter Rotor, L-L (Ohms)	Main Rotor (Ohms)	Main Stator Phase to Neutral, L-N (Ohms)	PMG Stator, L-L (Ohms)
			6,7,8 (E1, E2, E3) (V)	Main, L-L (V)						
HV804R	50	6.0	35	900	190-250	17.5	0.076	1.32	0.1489	3.8
	50	6.6	35	1000	190-250	17.5	0.076	1.32	0.1636	3.8
	50	10.0	35	1500	190-250	17.5	0.076	1.32	0.4716	3.8
	50	11.0	35	1650	190-250	17.5	0.076	1.32	0.6007	3.8
	60	7.2	35	1100	190-250	17.5	0.076	1.32	0.1489	3.8
	60	13.8	35	2100	190-250	17.5	0.076	1.32	0.6736	3.8
HV804S	50	6.0	35	900	190-250	17.5	0.076	1.40	0.1243	3.8
	50	6.6	35	1000	190-250	17.5	0.076	1.40	0.1549	3.8
	50	10.0	35	1500	190-250	17.5	0.076	1.40	0.3833	3.8
	50	11.0	35	1650	190-250	17.5	0.076	1.40	0.4903	3.8
	60	7.2	35	1100	190-250	17.5	0.076	1.40	0.1243	3.8
	60	13.8	35	2100	190-250	17.5	0.076	1.40	0.5554	3.8
HV804T	50	6.0	35	900	190-250	17.5	0.076	1.50	0.1068	3.8
	50	6.6	35	1000	190-250	17.5	0.076	1.50	0.1305	3.8
	50	10.0	35	1500	190-250	17.5	0.076	1.50	0.2981	3.8
	50	11.0	35	1650	190-250	17.5	0.076	1.50	0.4022	3.8
	60	7.2	35	1100	190-250	17.5	0.076	1.50	0.1068	3.8
	60	13.8	35	2100	190-250	17.5	0.076	1.50	0.4484	3.8



Alternator	Frequency (Hz)	Voltage at terminals				Resistance of windings at 20 °C				
		Phase to phase, L-L (kV)	Typical Residual		Normal	Exciter Stator (Ohms)	Exciter Rotor, L-L (Ohms)	Main Rotor (Ohms)	Main Stator Phase to Neutral, L-N (Ohms)	PMG Stator, L-L (Ohms)
			6,7,8 (E1, E2, E3) (V)	Main, L-L (V)						
HV804W	50	6.0	35	900	190-250	16	0.092	1.47	0.0668	3.8
	50	6.6	35	1000	190-250	16	0.092	1.47	0.0888	3.8
	50	10.0	35	1500	190-250	16	0.092	1.47	0.2368	3.8
	50	11.0	35	1650	190-250	16	0.092	1.47	0.3294	3.8
	60	7.2	35	1100	190-250	16	0.092	1.47	0.0668	3.8
	60	13.8	35	2100	190-250	16	0.092	1.47	0.3724	3.8
HV804X	50	6.0	35	900	190-250	16	0.092	1.63	0.0526	3.8
	50	6.6	35	1000	190-250	16	0.092	1.63	0.0717	3.8
	50	10.0	35	1500	190-250	16	0.092	1.63	0.1943	3.8
	50	11.0	35	1650	190-250	16	0.092	1.63	0.2540	3.8
	60	7.2	35	1100	190-250	16	0.092	1.63	0.0526	3.8
	60	13.8	35	2100	190-250	16	0.092	1.63	0.2868	3.8

---

This page is intentionally blank.

# 10 Service Parts and After Sales Service

## 10.1 Parts Orders

When ordering parts the machine serial number or machine identity number and type should be quoted, together with the part description. The machine serial number can be found on the name plate or frame.

## 10.2 Customer Service

Cummins Generator Technologies' service engineers are experienced professionals, trained extensively to deliver the best support possible. Our global service offers:

- On-site a.c. alternator commissioning
- On-site bearing maintenance & bearing condition monitoring
- On-site insulation integrity checks
- On-site AVR & accessories set-up

[www.stamford-avk.com](http://www.stamford-avk.com)

Email: [service-engineers@cumminsgeneratortechnologies.com](mailto:service-engineers@cumminsgeneratortechnologies.com).

## 10.3 Recommended Service Parts

In critical applications a set of these service spares should be held with the alternator.

Part	Number
MA330 AVR (if fitted)	E000-13300
DM110 AVR (if fitted)	E000-23800
Rectifier replacement kit (6 diodes, 2 varistors)	RSK6001
Rectifier resistor (R, S, T cores)	A048P674
Rectifier resistor (W, X, Y cores)	A048P676
Grease (if auto re-greaser not fitted)	45-0281
Auto re-greaser (if fitted)	A054A209
Grease (if auto re-greaser fitted)	A053Z748

**TABLE 20. BEARINGS, WITHOUT AUTOMATIC RE-GREASER FITTED**

Part	DE	NDE
R.S.T Cores	45-0408	45-0407
W.X.Y Cores	45-0409	45-0407

**TABLE 21. BEARINGS, WITH AUTOMATIC RE-GREASER FITTED**

Part	DE	NDE
R.S.T Cores	A054D228	A054D223
W.X.Y Cores	A054D231	A054D223

---

This page is intentionally blank.

# 11 End of Life Disposal

---

Companies specializing in reclaiming material from scrap products can reclaim most of the iron, steel and copper from the alternator. For more details, please contact Customer Service.

## 11.1 Recyclable material

Mechanically separate the base materials, iron, copper and steel, removing paint, polyester resin, and insulation tape and/or plastics residues from all components. Dispose of this 'waste material'

The iron, steel and copper can now be recycled.

## 11.2 Items requiring specialist treatment

Remove electrical cable, electronic accessories and plastic materials from the alternator. These components need special treatment to remove the waste from the reclaimable material.

Forward the reclaimed materials for recycling.

## 11.3 Waste material

Dispose of waste material from both of the above processes via a specialist disposal company.

-

---

This page is intentionally blank.





[www.stamford-avk.com](http://www.stamford-avk.com)

Copyright 2015, Cummins Generator Technologies Ltd. All Rights Reserved  
Cummins and the Cummins logo are registered trademarks of Cummins Inc.