

REL NO	REV	NO	REVISION	DWN	CKD	APVD	DATE
ECO-180150	A	1	PRODUCTION RELEASE	KDP	NPDI	I.SAUNDATTI	18SEP18

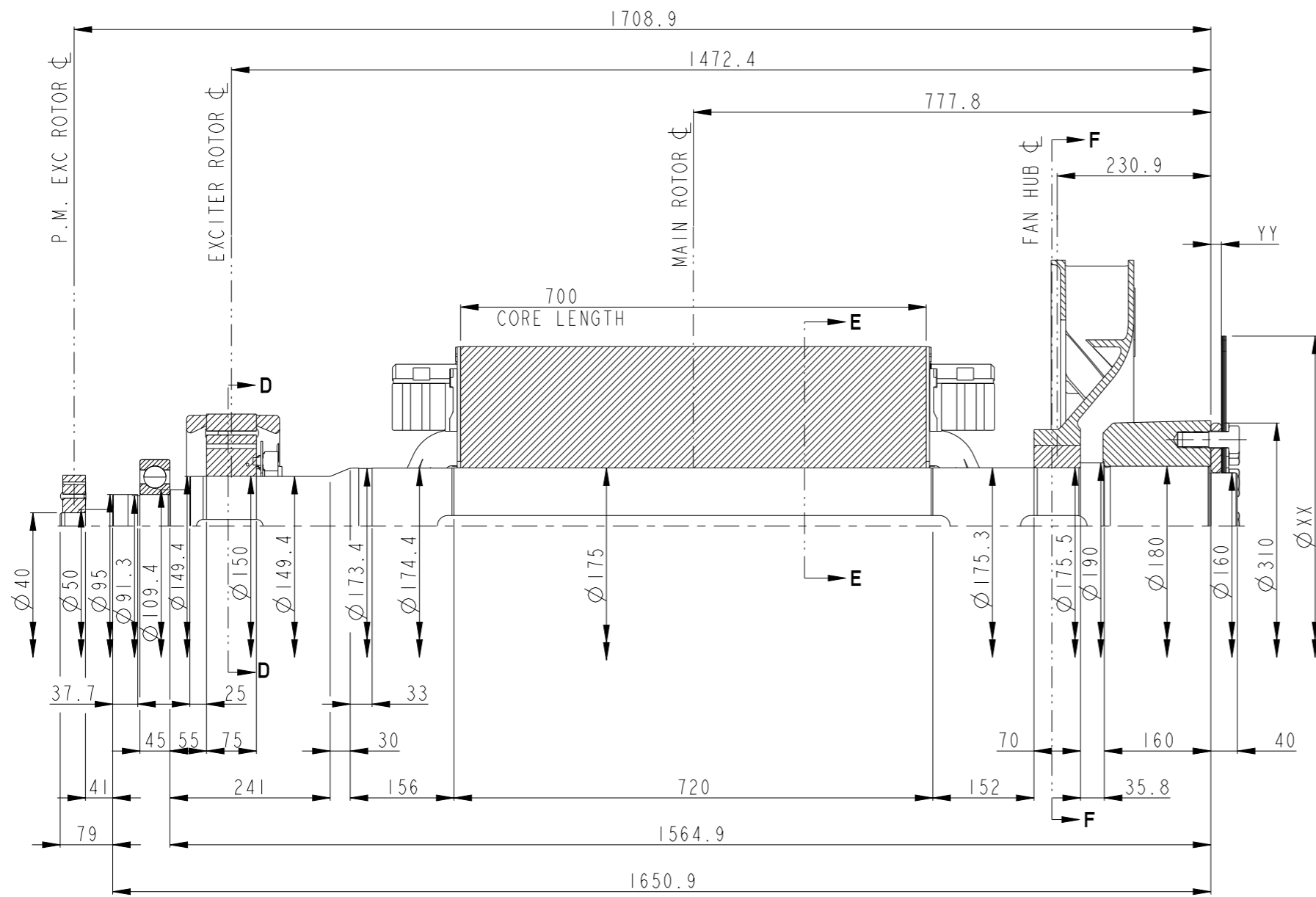

NOTES:

- SHAFT STIFFNESS:
THE STIFFNESS OF THE SHAFT BETWEEN THE MAIN ROTOR CORE ϕ AND THE COUPLING HUB IS 120.46×10^6 kgcm/radian (STIFFENING EFFECT OF MAIN ROTOR CORE IS NOT INCLUDED IN THIS FIGURE)
- SHAFT PROPERTIES:
MINIMUM YIELD : 260MPa
MINIMUM ULTIMATE TENSILE STRENGTH : 530MPa
SHAFT MATERIAL IS APPROVED BY MARINE AUTHORITIES WHEN APPROPRIATE
- MAXIMUM RECOMMENDED VIBRATORY STRESS LEVEL IN THE SHAFT IS 34.47×10^6 N/M² FOR SPEED RANGE OF 0.95 TO 1.1 NOMINAL SPEED AND 68.94×10^6 N/M² FOR RUN THROUGH CONDITIONS, FOR INDUSTRIAL MACHINES
- FOR MARINE AUTHORITIES, THEIR APPROPRIATE RULES WILL APPLY
- CUMMINS GENERATOR TECHNOLOGIES LTD SHOULD BE NOTIFIED OF ANY ROTORS NOT COMPLYING WITH THESE RULES. CUMMINS GENERATOR TECHNOLOGIES LTD BALANCE ROTORS TO COMPLY WITH INTERNATIONAL STD ISO 1940 GRADE 2.5 AND BS 6861 PART 1 GRADE 2.5
- FOR UNBALANCED MAGNETIC PULL (U.M.P) FORCES PLEASE CONTACT CUMMINS GENERATOR TECHNOLOGIES LTD

COMPONENT	Wt Kg	WR ² Kg m ²
FAN	28.800	1.6520
HUB	57.063	0.9276
SHAFT	291.36	1.0684
MAIN ROTOR	1056.084	41.0301
EXCITER ROTOR	46.791	0.7758
P.MAG ROTOR	6.970	0.0190
STUB SHAFT	0.929	0.0003
TOTAL	1487.997	45.4732

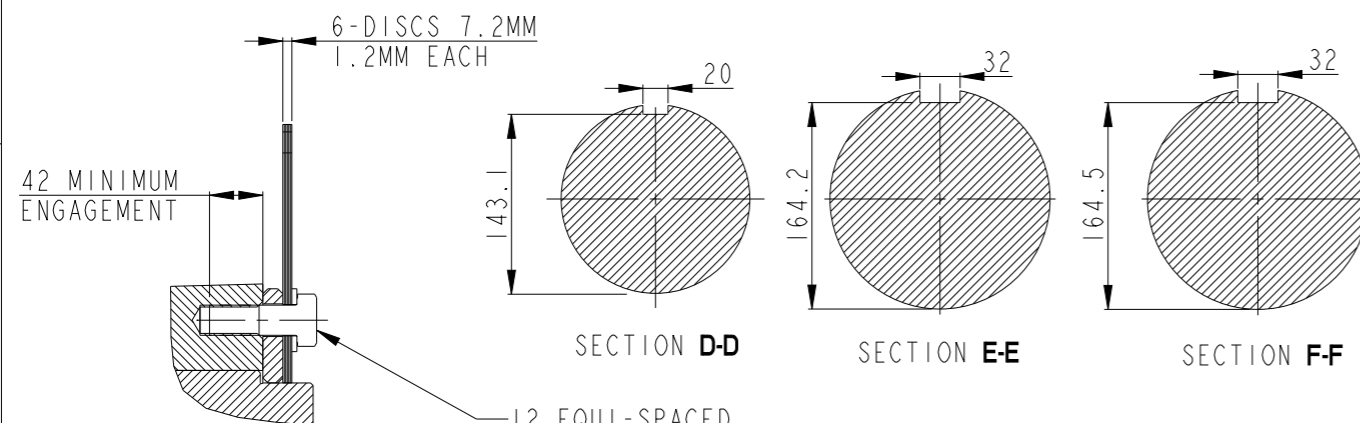

CONVERSION FACTORS		
TO CONVERT	TO	DIVIDE BY
kg	lb	0.453592
kg m ²	lb ft ²	0.04214
kgcm/rad	lbin/rad	1.1521246
N/m ²	lbf/in ²	6894.76

COUPLING SAE No.	COUPLING DIMENSIONS		TOTAL MASS OF COUPLING ASSEMBLY (kg)	COUPLING STIFFNESS (kgcm/rad)	COUPLING DISC WR ² (kg m ²)
	ϕ XX mm	YY mm			
18	572	16	24.5	1592×10^6	0.590
21	673	00	23.1	1468×10^6	1.135
24	733	00	26.84	1428×10^6	1.598

SECTION THRU SHAFT END AND COUPLING SCREWS OR BOLTS
12 EQUI-SPACED SCREWS OR BOLTS M24 X 3 PITCH ON 260 P.C.D

UNLESS OTHERWISE SPECIFIED, ALL DIMENSIONS ARE IN MILLIMETERS

SCALE 1:1

THIS DOCUMENT (AND THE INFORMATION SHOWN THEREON) IS CONFIDENTIAL AND PROPRIETARY AND SHALL NOT BE DISCLOSED TO OTHERS IN HARD COPY OR ELECTRONIC FORM, REPRODUCED BY ANY MEANS, OR USED FOR ANY PURPOSE WITHOUT WRITTEN CONSENT OF CUMMINS INC.

SIM TO -

DO NOT SCALE PRINT

FOR INTERPRETATION OF DIMENSIONING AND TOLERANCING, SEE ASME Y14.5-2009

DWN	K.PAWAR
CKD	N.DAHIWELKAR
APVD	I.SAUNDATTI
DATE	18SEP18
FIRST USED ON	S7

CUMMINS

CUMMINS GENERATOR TECHNOLOGIES

DRAWING, TORSIONAL

S7G, 4POLE 1B

SITE CODE

PUN

DWG SIZE A2

A060H164

CAD SHEET 1 of 1