

DL15-12630

ISSUE
A

IF IN DOUBT-ASK
DO NOT SCALE

FIRST W.O.

NOTES !

SHAFT STIFFNESS:-
THE STIFFNESS OF THE SHAFT BETWEEN THE MAIN ROTOR CORE ϕ AND THE COUPLING HUB FACE IS $7,61 \times 10^6$ kgcm/radian
(STIFFENING EFFECT OF MAIN ROTOR CORE IS NOT INCLUDED IN THIS FIGURE).

SHAFT MATERIAL:-
STEEL - 080M40 TO BS970 PART 1 (APPROVED BY MARINE AUTHORITIES WHEN APPROPRIATE).
MAXIMUM RECOMMENDED VIBRATORY STRESS LEVEL IN THE SHAFT IS $34,47 \times 10^6$ N/m² FOR A SPEED RANGE OF 0,95 TO 1,1 x NOMINAL SPEED, AND $68,94 \times 10^6$ N/m² FOR RUN THROUGH CONDITIONS, FOR INDUSTRIAL MACHINES. FOR MARINE AUTHORITIES, THEIR APPROPRIATE RULES WILL APPLY.
NEWAGE INTERNATIONAL LTD. SHOULD BE NOTIFIED OF ANY ROTORS NOT COMPLYING WITH THESE RULES.
NEWAGE INTERNATIONAL LTD. BALANCE ROTORS TO COMPLY WITH INTERNATIONAL STD. I.S.O. 1940 GRADE 2,5 AND B.S. 6861 PART 1 GRADE 2,5.
FOR UNBALANCED MAGNETIC PULL (U.M.P.) FORCES REFER TO GENERATOR MANUAL.

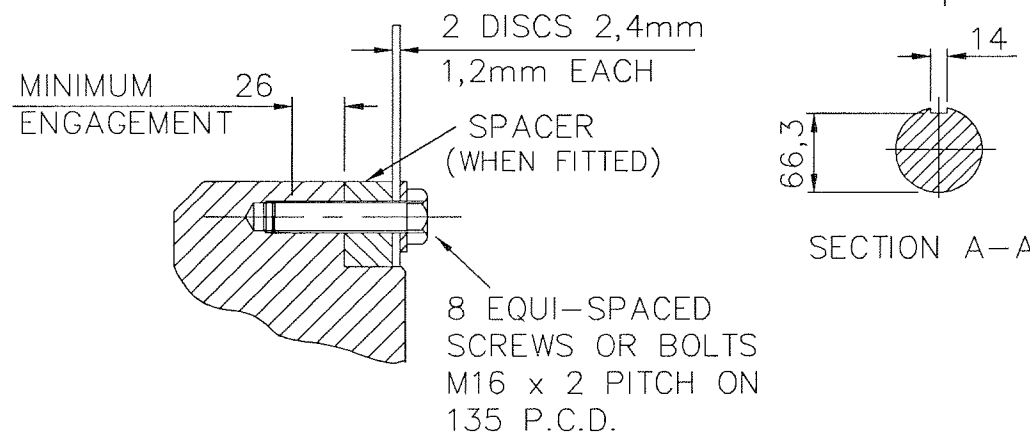
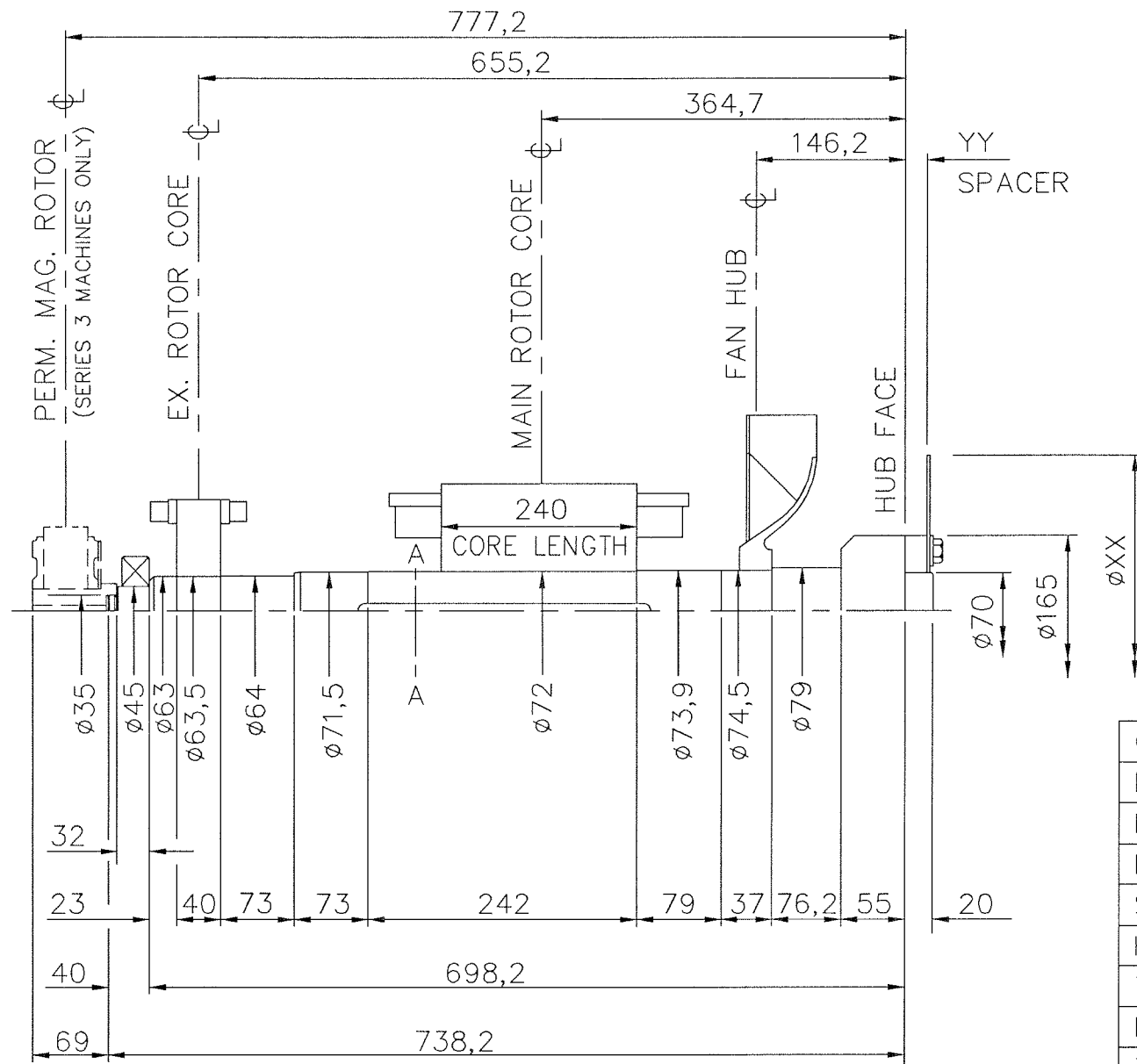

COMPONENT	Wt kg	WR ² kgm ²
EX. ROTOR	8,490	0,0508
MAIN ROTOR	64,470	0,4693
FAN	1,940	0,0271
SHAFT	23,247	0,0149
HUB	7,093	0,0300
TOTAL	105,240	0,5921
PERM. MAG.	5,450	0,0150
TOTAL	110,690	0,6071

COUPLING SAE No	COUPLING DIMEN's		COUPLING ASSEMBLY WEIGHT kg	COUPLING STIFFNESS 2-PLATES kgcm/rad	COUPLING DISC WR ² kgm ²
	XX	YY			
* 8	263	22,2	4,43	$164,4 \times 10^6$	0,0087
* 10	314	14,3	3,70	$144,3 \times 10^6$	0,0178
* 11½	352	-	1,76	$136,5 \times 10^6$	0,0282
! 11½	352	14,3	4,07	$136,5 \times 10^6$	0,0282
! 14	467	-	3,16	$126,1 \times 10^6$	0,0878
15½" DIA	394	-	2,22	$129,3 \times 10^6$	0,0763

CONVERSION FACTORS		
TO CONVERT	TO	DIVIDE BY
kg	lb	0,453592
kg m ²	lb ft ²	0,04214
kgcm/rad	lbin/rad	1,1521246
N/m ²	lbf/in ²	6894,76

NOTES

- 1.*COUPLING DETAILS NOT APPLICABLE WHEN USED WITH SAE No 1 FLYWHEEL HOUSING
- 2.!COUPLING DETAILS APPLICABLE TO SAE No 1 FLYWHEEL HOUSING ONLY

4/2892/5	A	S.M.C.	08.11.00	ORIGINAL ISSUE
MOD'N	ISSUE	DRAWN	DATE	ALTERATION

CERTIFIED PRINT (ONLY IF SIGNED) BY DATE	UC224F-SINGLE BEARING MOMENTS OF INERTIA AND SHAFT DETAILS	SCALE	FIRST W.O.
		NTS	UNIT OF MEASUREMENT MILLIMETRES (mm)
DRAWN S.M.C. 08.11.00 CH'D S.M.C. 20.11.00 APP'D S.M.C. 20/11/00	NEWAGE INTERNATIONAL LTD STAMFORD ENGLAND	DL15-12630	ISSUE A